



# BODY SERVICE

This publication contains essential removal, installation, adjustment and maintenance procedures for servicing P body styles. This information is current as of time of publication approval.

## TABLE OF CONTENTS

TITLE	SECTION
GENERAL INFORMATION	1
WIPER SYSTEMS	See Section 8E in the chassis portion of this manual.
UNDERBODY	3
FRONT END	4
DOORS	5
REAR QUARTERS	6
REAR END	7
ROOF	8
SEATS	9
ELECTRICAL	10
STATIONARY GLASS	11
INDEX	



# SECTION 1

## GENERAL INFORMATION

### CONTENTS

Lock Cylinder Coding .....	1-1	Reaction Injection Molded Parts .....	1-6
Key Identification and Usage .....	1-1	Painting of Exterior Panels .....	1-8
Cutting Keys .....	1-1	Interior Plastic Trim and Parts	
Replacement Lock Cylinders .....	1-1	Finishing .....	1-10
Assembling and Coding Lock Cylinders .....	1-1	Test for Plastic Identification .....	1-10
Lubrication .....	1-2	Test for Polypropylene and ABS	
Waterleak Diagnosis .....	1-2	Plastic .....	1-10
Generalized Testing .....	1-3	Test for Vinyl Plastic .....	1-10
Localized Testing .....	1-3	Painting Polypropylene Plastic Parts .....	1-10
Water Hose Test .....	1-3	Painting Rigid or Hard ABS Plastic	
Air Hose Test .....	1-3	Parts .....	1-10
Waterleak Repair .....	1-3	Painting Vinyl and Flexible (soft) ABS	
Anticorrosion Treatment .....	1-3	Plastic Parts .....	1-11
Body Repair		Availability of Colors for Painting Interior	
Exterior Panel Identification .....	1-6	Plastic Parts .....	1-11
Sheet Molded Compound .....	1-6	Special Body Tools .....	1-11
Reaction Injection Molded and Reinforced			

## LOCK CYLINDER CODING

### KEY IDENTIFICATION AND USAGE

The lock cylinder keyway is designed so that other model keys will not enter a current model lock cylinder. Two noninterchangeable keys are used.

- Square headed key is used for the ignition lock cylinder.
- Oval headed key is used for the door and the rear compartment lock.

Key identification is obtained from the four character key code stamped on the knockout portion of the key head and an identification letter stamped on the key shank. After the code number has been recorded by the owner, plugs should be knocked out of the key head. These numbers are used to determine the lock combinations by the use of a code list (available to owners of key cutting equipment from the equipment suppliers). If key code numbers are not available from records or from the knockout plug, lock combination (tumbler numbers and position) can be determined by laying the key on the diagram in Figure 1-1.

### CUTTING KEYS

- Determine special code from code list or from key code diagram.
- Cut blank key to proper level for each of the six tumbler positions.
- Check key operation in the lock cylinder.

### REPLACEMENT LOCK CYLINDERS

New lock cylinders are available from service parts warehouses. The new cylinder has a new locking

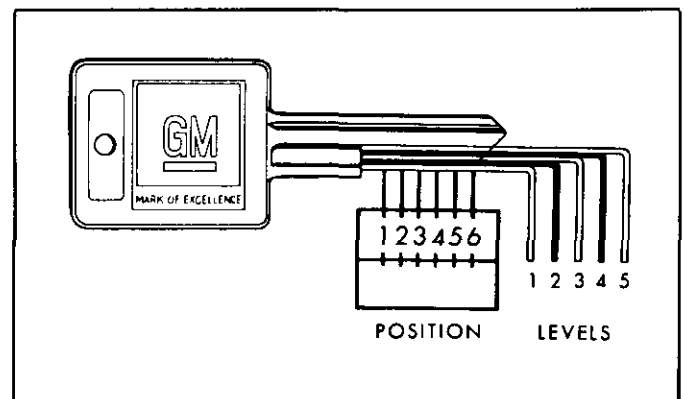

Fig. 1-1-Key Code Diagram

bar staked in place. New tumblers are also available and must be assembled into the cylinder.

### ASSEMBLING AND CODING LOCK CYLINDERS

The tumblers for all locks are shaped exactly alike except for the notch position on one side. As the key is inserted in the lock cylinder, tumblers are lowered to the correct height so that the notches on each tumbler are at the same level. When the notches on all six tumblers line up, the side bar is pushed into the notches by two small springs. This allows the cylinder to turn in its bore. Five different tumblers are used to make various lock combinations. Each tumbler is coded according to a number, 1 through 5, stamped on its side.



**Assemble (Figures 1-2 and 1-3)**

1. Determine tumbler numbers and arrangement.

## 1-2 GENERAL INFORMATION

- With numerical key code, use code list provided by key cutter equipment supplier.
  - Without numerical key code or without code list, refer to Figure 1-1.
    - Position key on key code diagram. Be sure key is outlined by the diagram.
    - Start with position number 1, find and record lowest level (tumbler number) that is visible. Repeat for each of the remaining five positions.
2. Start with position number one (open end or head of cylinder). Insert correctly numbered tumblers in their respective positions.
  3. Pull side bar out with fingers to allow tumblers to drop completely into place.
  4. Insert one tumbler spring above each tumbler.

**NOTICE:** If the springs become tangled, do not pull them apart, unscrew them to prevent damage.

5. Insert spring retainer so that the end prongs slide into slots at each end of cylinder. Press retainer down.
6. Insert key into cylinder to check for proper installation.

### Inspect

Side bar should drop down if tumblers are properly installed. If incorrectly assembled, disassemble and reassemble correctly.

7. Once tumblers have been pressed down into the cylinder they are held by the side bar. To remove them, hold cylinder with tumbler slots down. Pull side bar out with fingers. Jar cylinder to shake tumblers out.

**NOTICE:** Use leather or wood at each vise jaw to prevent damage to cylinder.

8. Remove key and secure cylinder in a vise with spring retainer exposed.
9. Stake spring retainer securely in place at each end. Use suitable staking tool and stake cylinder metal over retainer.
10. Lubricate cylinder with a light oil.

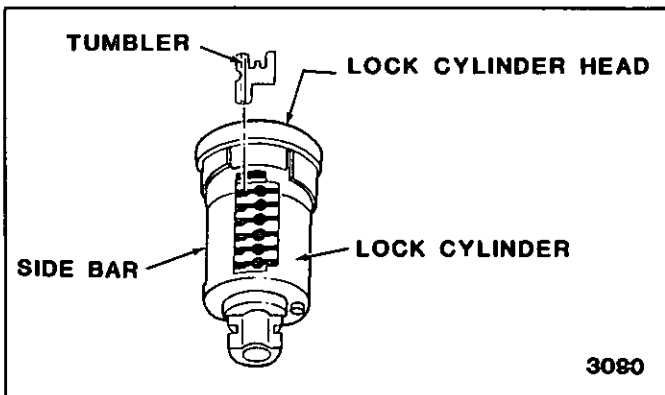

Fig. 1-2 Installing Tumblers

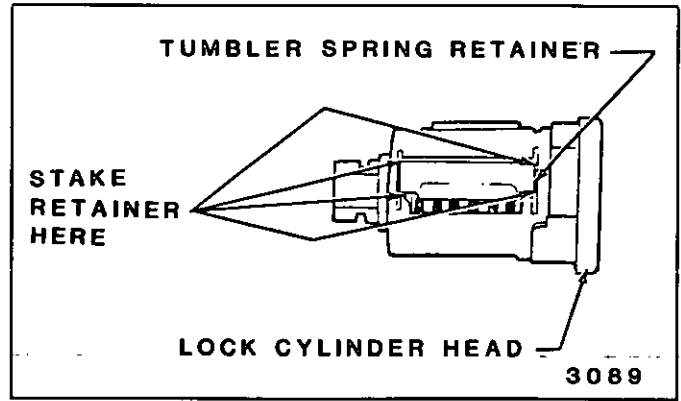

Fig. 1-3-Installing Spring Retainer

## LUBRICATION

Mechanical parts having contacting surfaces in relative motion with other body parts are lubricated during assembly. To maintain ease of operation, it is recommended that these parts be lubricated at the basic service intervals shown in the Maintenance Schedule with the following lubricants.

- Door hinge - engine oil (30 weight preferred) Apply to roller and hinge pin bushings

### Important

Do not apply to hold-open link and roller contacting surface as this could cause improper roller operation.

- Locks, compartment lid hinge and torque rods - Part number 1052196, Lubriplate Auto-Lube A, Part number 1052349, Lubriplate Spray-Lube A, 3M Lithium Spray Lube No. 8915 (or equivalent).
- Lock cylinder - a light oil.
- Seat mechanism and door hardware are covered in the specific body area sections in this manual.

## WATERLEAK DIAGNOSIS

GM vehicles are designed to operate under normal environmental conditions. The design criteria for sealing materials and components takes into consideration the sealing forces required to withstand the natural elements. These specifications do not, and cannot, take into consideration all artificial conditions such as may be encountered in some high pressure car washes.

The watertest procedure has been correlated to the natural elements and will determine the ability of a car to perform under normal operating conditions.

Repairing body waterleaks is a problem of proper testing, diagnosis and repair through adjustment of misaligned components and/or application of proven repair materials. The first step in waterleak diagnosis is finding the conditions under which the leak occurs. For example, leak noticed only when parked on an inclined drive, water in spare tire compartment.

If the general leak area can be found, the exact

watertest equipment such as the watertest stands shown in Figure 1-4 should be used. This test applies a large volume of water to a general area without going over the sealing limitations of side glass, door or rear compartment opening weatherstrips. Also, the use of the test stands or similar watertest equipment is advised for retest to confirm repair and see if any other leaks may be adding to the original condition.

### GENERALIZED TESTING

To watertest a broad area, a watertest stand or similar watertest equipment as shown in Figures 1-4 and 1-5 should be used.

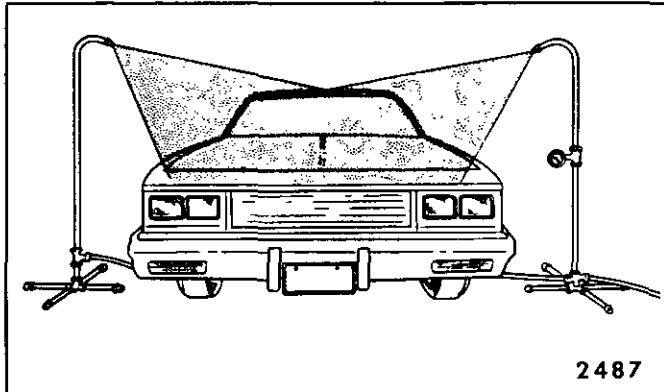

Fig. 1-4-Watertest Stands Positioned for Front End Watertest

Specifications for construction of the watertest stand are shown in Figure 1-6.

If the specified water pressure of 155 kPa (22 psi) cannot be obtained because of a local situation, both test stands may be moved toward body until water spray overlap can be obtained.

### LOCALIZED TESTING (SPOT TEST)

Localized testing may be made with either water or air. Begin test at the base of the suspected area and continue up slowly until the leak is located.

#### ! Important

Pinpoint the leak area before any repair is made. Random repair may only temporarily restrict water entry and make future diagnosis and repair more difficult.

Continue localized testing in the same general area to confirm that all leaks have been located.

### WATER HOSE TEST (FIGURE 1-7)

- Have a helper inside the car to detect the actual leak point.
- Use unrestricted water flow (no nozzle).
- Begin at base of test area and move upward.

### AIR HOSE TEST (FIGURE 1-8)

- Apply bubble solution (liquid soap) to suspected area.
- Apply air pressure with an air hose from inside vehicle. Do not exceed 205 kPa (30 psi)
- Observe for bubbles on outside at test area.

### WATERLEAK REPAIR

To locate the exact leak point, or to repair the leak, it may be necessary to remove some interior trim panels or components.

- Windshield and back window  
Repair with adhesive caulking kit no. 9636067 or equivalent as described in Section 11.
- Shroud area leaks  
*Metal joint area leak* – use a brushable seam sealer (or equivalent) which can be painted.  
*Sealed components such as ventilation ducts* – use 3M Auto Bedding and Glazing Compound (or equivalent).

#### ! Important

Water entry through the high level ventilation ducts may be due to a damaged duct shroud vent screen or a blockage in the shroud drain.

- Windshield pillar drip molding – use 3M Auto Bedding and Glazing Compound (or equivalent)
- Metal joints rear compartment  
*Small cracks or pin holes* – use 3M Drip-Chek sealer (or equivalent).  
*Larger holes* – use 3M All-Around Autobody Sealant No. 8500 (or equivalent).

#### 🔍 Inspect

For proper repair

After completion of any waterleak repair, the general area should be retested using the watertest stand. Do not use air hose or water hose to test repaired areas as the repair material may dislodge under abnormal pressure.

### ANTICORROSION TREATMENT

The use of urethane and fiberglass exterior panels and wheelhouse liner and splash shields has greatly reduced the potential for corrosion. Some galvanized metal is used, and special metal conditioners and primers are used on surfaces in areas where moisture might accumulate. Sealers are applied along exposed joints.

Any procedure that disturbs these treatments, such as collision damage repair operations, may leave the metal unprotected and result in corrosion. Therefore, proper recoating of the surfaces with service-type anticorrosion material is an essential function of the repair operation and cannot be overemphasized.

Metal conditioners and primer coatings are applied to all metal panels at the time of vehicle manufacture. After repair and/or replacement part installation, all accessible bare metal surfaces must be treated with metal conditioner and reprimed using an acrylic chromate material. This operation is to be performed prior to the application of sealers, deadeners and antirust compounds.

Sealers are applied to specific joints during manufacture. These sealers are intended to prevent water and dust from entering the car and also perform as anticorrosion barriers. The originally sealed joints are obvious and any damage to these sealed locations

## 1.4 GENERAL INFORMATION

### WATERTEST STAND SPECIFICATIONS

TYPE OF NOZZLE — FULL CONE SPRAY WITH 60° INCLUDED ANGLE — "FULL JET" SPRAY NOZZLE NO. 1/2 GG-25 OR EQUIVALENT.

NOZZLE HEIGHT — APPROXIMATELY 1 600 mm (63") FROM FLOOR

VOLUME OF FLOW — 14 LITERS (3.7 GALLONS) PER MINUTE

PRESSURE — 155 kPa (22 PSI) MEASURED AT NOZZLE

WINDSHIELD AND FRONT BODY PILLAR — APPROXIMATELY 30 DEGREES DOWN, 45 DEGREES TOWARDS REAR AND AIMED AT CORNER OF WINDSHIELD

SIDE — APPROXIMATELY 30 DEGREES DOWN, 45 DEGREES TOWARDS REAR AND AIMED AT CENTER OF REAR DOOR OR REAR QUARTER.

BACK WINDOW AND REAR COMPARTMENT LID — APPROXIMATELY 30 DEGREES DOWN, 30 DEGREES TOWARDS FRONT AND AIMED APPROXIMATELY 600 mm (24") FROM CORNER OF BACK WINDOW.

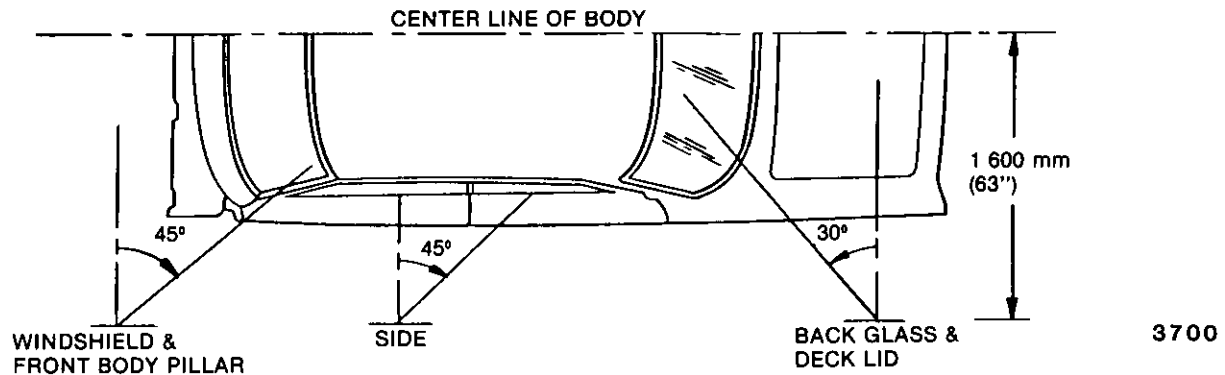

Fig. 1-5-Watertest Stand Specifications

should be corrected by resealing. Attaching points of new replacement panels should be resealed (Fig. 1-9).

Flanged joints, overlap joints and seams should be sealed using quality sealer of medium-bodied consistency. Sealer used must retain its flexible characteristics after curing and be paintable.

Open joints which require bridging of sealer to close a gap should be sealed using a heavy-bodied caulking material.

Manufacturers' labels should be checked for material usage, recommendations, characteristics and application instructions.

Color application may be required to restore repaired areas such as engine compartment, underbody and inner panels to original appearance. When this is necessary, conventional refinishing preparation, undercoat buildup and color application techniques should be followed.

Deadener materials (spray-on type) are used on various metal panels to provide corrosion resistance, joint sealing and to control the general noise level inside the passenger area of the vehicle. When deadeners are disturbed because of damage, removed during repair operations, or a new replacement panel is installed, the deadener material must be replaced by a service equivalent material. The application pattern and location of deadener materials can be determined by observing the original production installation.

Anticorrosion compounds are light-bodied materials designed to penetrate between metal-to-metal

materials and are inaccessible for painting. One material suited for this type application is Anti-Corrosion Compound Part No. 1052290 (or equivalent).

Conventional undercoating using Guard-Mor or equivalent protective material is recommended to coat large areas such as floor pan sections. The material should not be applied to any moving or rotating part, energy absorbing bumper components, shock absorbers or on the floor pan in the area of the catalytic converter. After undercoating, care should be taken to assure that all body holes are open.

Sequence of application steps for anticorrosion materials is as follows:

1. Clean and prepare metal.
2. Apply primer (acrylic chromate).
3. Apply sealers (all previously sealed joints).
4. Apply color in areas where color is required, such as hem flanges, exposed joints and underbody components.
5. Apply deadeners (as indicated by original application pattern).
6. Apply anticorrosion compounds.
7. Apply underbody rustproofing material.

Cleaning of interior and underbody panel surfaces is necessary when original galvanize or other anticorrosion materials have been burned off during welding or heating operations. Removal of the residue left from burning will require additional care in such

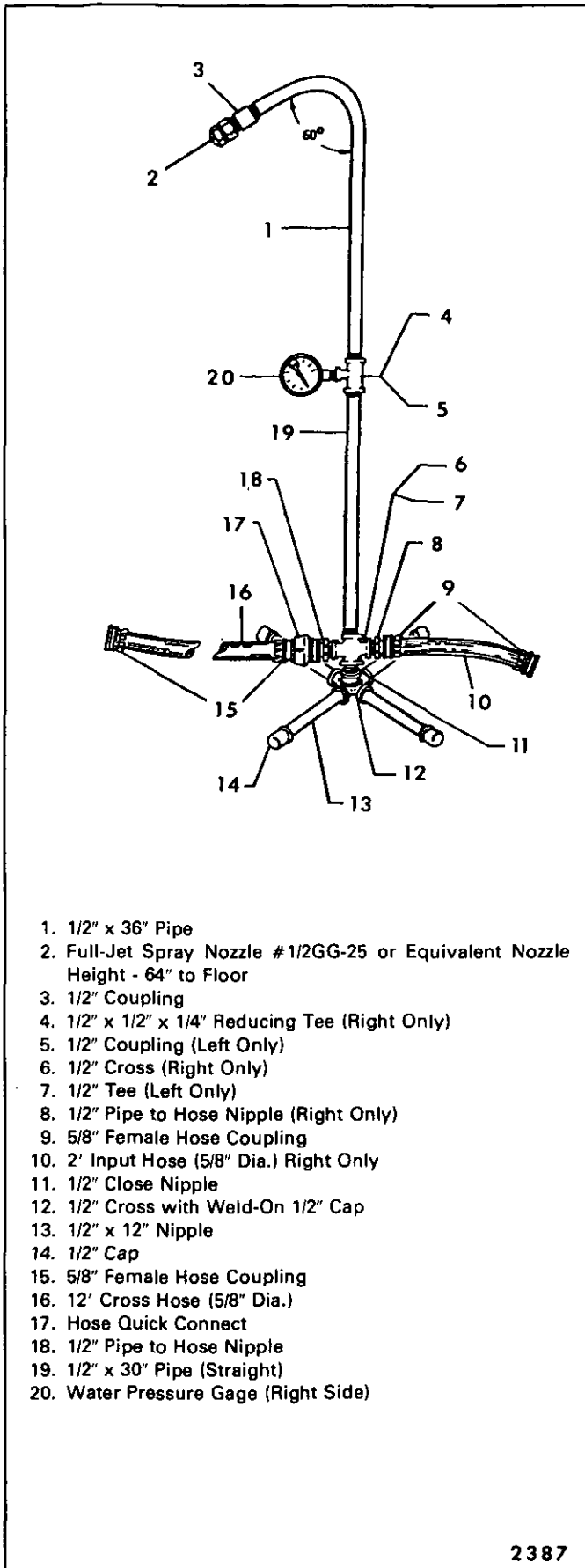

1. 1/2" x 36" Pipe
2. Full-Jet Spray Nozzle #1/2GG-25 or Equivalent Nozzle Height - 64" to Floor
3. 1/2" Coupling
4. 1/2" x 1/2" x 1/4" Reducing Tee (Right Only)
5. 1/2" Coupling (Left Only)
6. 1/2" Cross (Right Only)
7. 1/2" Tee (Left Only)
8. 1/2" Pipe to Hose Nipple (Right Only)
9. 5/8" Female Hose Coupling
10. 2' Input Hose (5/8" Dia.) Right Only
11. 1/2" Close Nipple
12. 1/2" Cross with Weld-On 1/2" Cap
13. 1/2" x 12" Nipple
14. 1/2" Cap
15. 5/8" Female Hose Coupling
16. 12' Cross Hose (5/8" Dia.)
17. Hose Quick Connect
18. 1/2" Pipe to Hose Nipple
19. 1/2" x 30" Pipe (Straight)
20. Water Pressure Gage (Right Side)

2387

Fig. 1-6-Watertest Stand

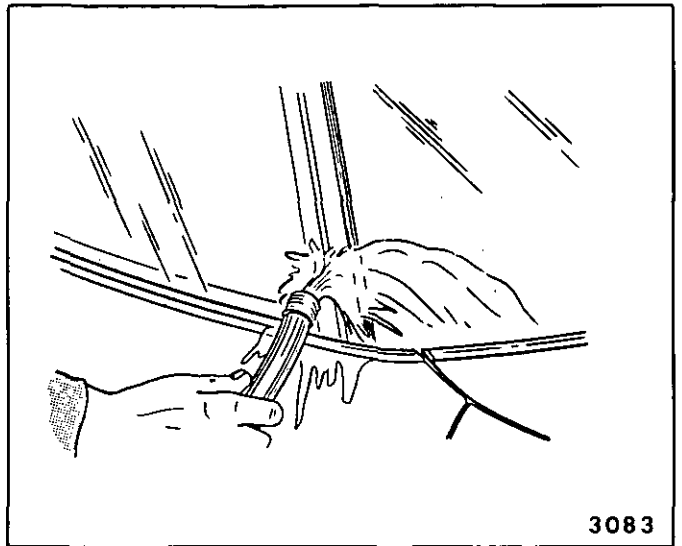

3083

Fig. 1-7-Water Hose Test of Windshield Pillar

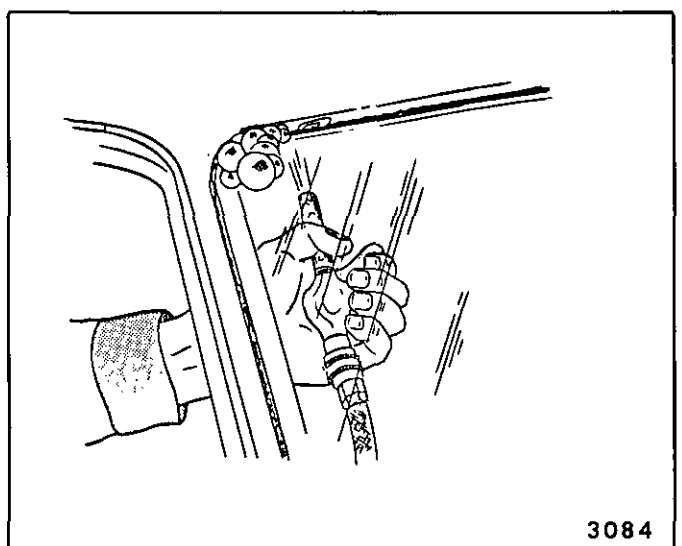

3084

Fig. 1-8-Air Hose and Bubble Solution Test of Windshield Glass Sealant

following methods will satisfactorily remove the residue.

**CAUTION: Standard shop safety practices, particularly eye protection, should be followed during these operations to avoid personal injury.**

- Where access is possible, scraping can be used. If a standard putty knife or scraper will not fit into the affected area, consider fabricating a small, flexible scraper from a narrow piece of sheet metal.
- A jet of compressed air will remove most residue and could be most effective in limited-access areas. Eye protection is absolutely necessary in an operation of this type.
- Sandblasting is most effective and should be used when the equipment is available and access to the area is good. Sandblasting is an excellent method for cleanup and preparation of open joints, underbody components and hem flange areas.
- Wire brushing (power and by hand).
- When accessibility is good, sandpaper and steel wool can be used.

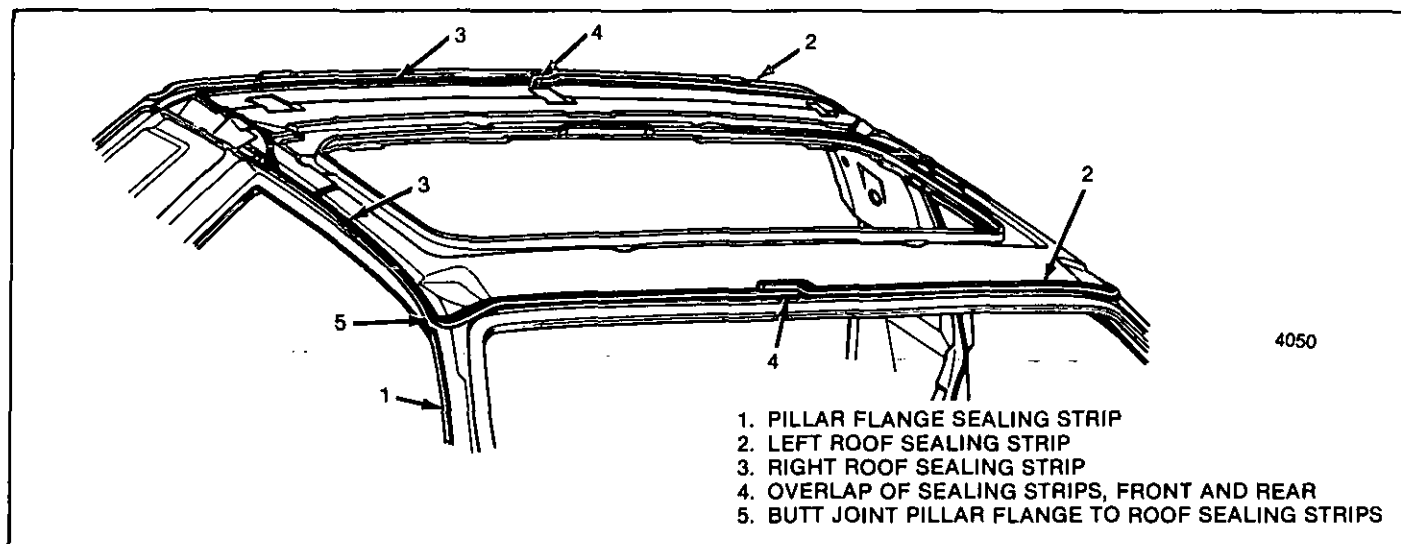

Fig. 1-9-Sealing Locations

## BODY REPAIR

### EXTERIOR PANEL IDENTIFICATION

All exterior panels are made from reaction injection molded urethane (RIM), glass fiber reinforced RIM (RRIM), sheet molded compound (SMC) or thermoplastic olefin (TPO). They are not susceptible to rust and can sustain minor impact without damage. However, if the impact force is great enough to create damage, they can be successfully repaired and refinished.

Different materials require different procedures for repair and refinishing. Before starting any repair, identify the type of material involved using Figure 1-10 and follow the correct procedure.

### SHEET MOLDED COMPOUND (SMC) PARTS

Any SMC panel may be repaired using structural adhesives and the procedure outlined for RIM and RRIM. However, on SMC panels when structural strength is not involved, you may use a polyester body filler for repair. Simple economics should dictate the repair method.

As an example, a surface gouge on an SMC part where structural strength is not involved may be more economically repaired with polyester body filler. On the other hand, puncture damage that requires a backup or structural type repair that requires reinforcing the back side can be accomplished by using a combination of structural adhesive and polyester body filler. Since epoxy resin possess superior adhesive properties, all repair work done on the back side of the part should be done with fiberglass cloth and structural adhesive. Then, cosmetic repair on the face side of the part may be completed with polyester body filler.

### REACTION INJECTION MOLDED (RIM) AND REINFORCED REACTION INJECTION MOLDED (RRIM) PARTS

Briefly, the repair system amounts to a filling and where necessary, a reinforcing operation. After curing, the patch is dressed to conform to the surrounding contour.

Following are typical damage conditions and respective repair procedures:

1. Gouge or puncture repair
  - a. Clean the repair area with a wax, grease and silicone removing solvent applied with a water-dampened cloth. Wipe dry. With a random orbit sander fitted with a #180 grit disc, remove the paint film in and surrounding the area to be filled. The repair material should **not** overlap the painted surface (Fig. 1-11).
  - b. Use a **clean** 50 or 75 mm (2" or 3") #50 grit disc to enlarge the gouge or puncture in order to ensure removal of grease, oil or dirt from the area to be contacted by the repair material. This action should also create at least a 25 mm (1") taper around the damage for extended contact between the repair material and substrate. Remove all dust and loose particles from the repair area (Fig. 1-12).  
Aluminum Autobody Repair Tape (3M #06935, #06936 or equivalent) can be used on the back side of a puncture to support the repair material (Fig. 1-13).
  - c. On a clean flat surface of nonporous material such as metal, glass or plastic, deposit equal length beads of each component (3M Flexible Parts Repair Material #05900 or 3M Brand Structural Adhesive #08101 or equivalent). With a paddling motion, mix the two components until uniform color and consistency is achieved (Fig. 1-14).



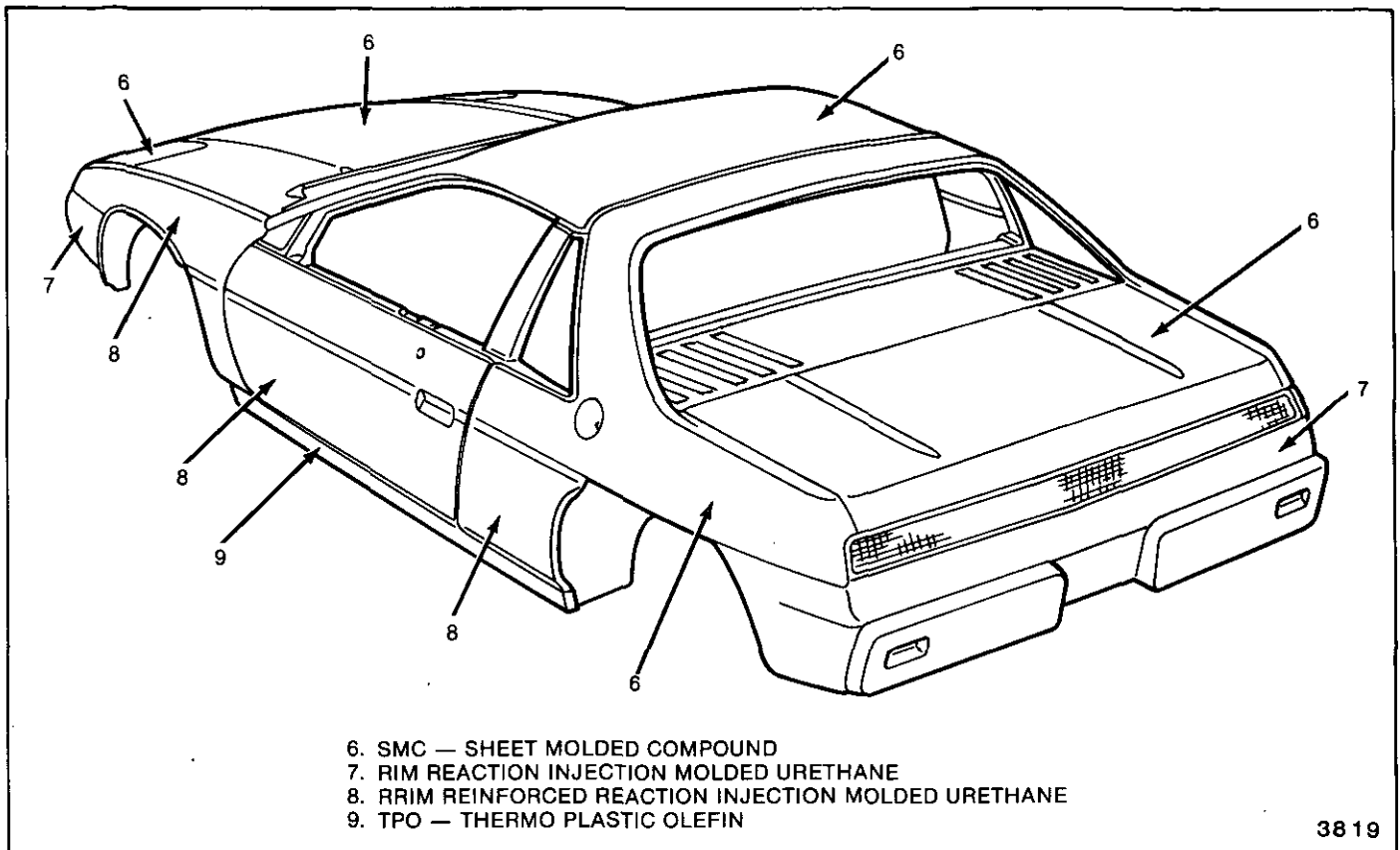

Fig. 1-10-Exterior Panel Identification

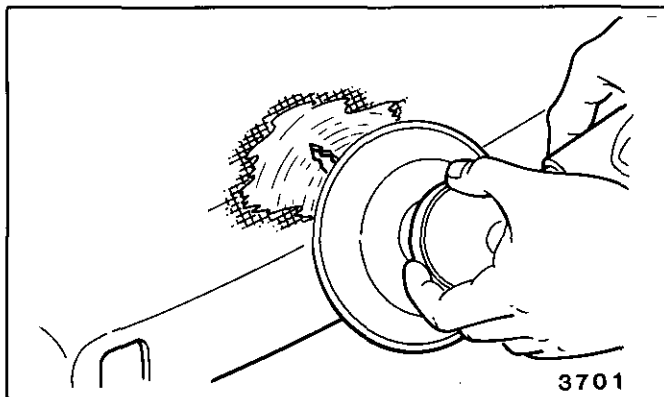

Fig. 1-11-Removing Paint Surrounding Damage

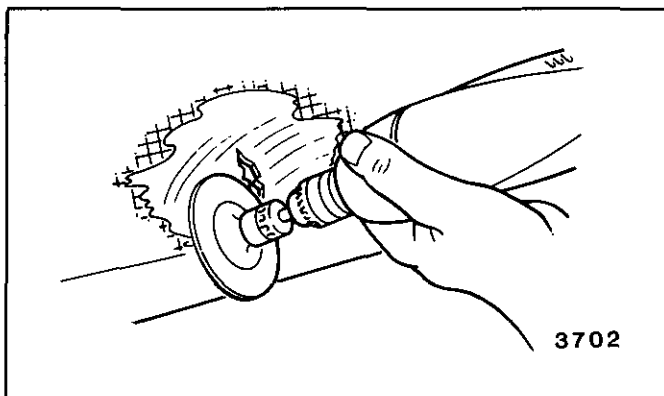

Fig. 1-12-Tapering Substrate Surrounding Damage

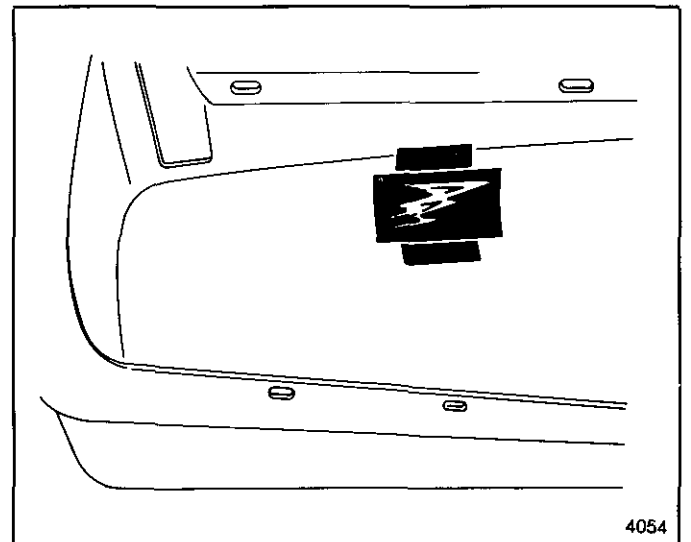

Fig. 1-13-Tape Support for Repair Material

coat over the entire area; then continue application to a level slightly above the surrounding contour. Allow the mixture to cure 20 to 30 minutes at 16 to 27°C (60 to 80°F). If low areas or pits remain, mix and spread additional adhesive (Fig. 1-15).

- e. Establish rough contour, where possible, with a curved tooth body file. Follow by block sanding using #220 sandpaper to establish accurate level and contour with the surrounding surface (Figs. 1-16 and 1-17).

## 1-8 GENERAL INFORMATION

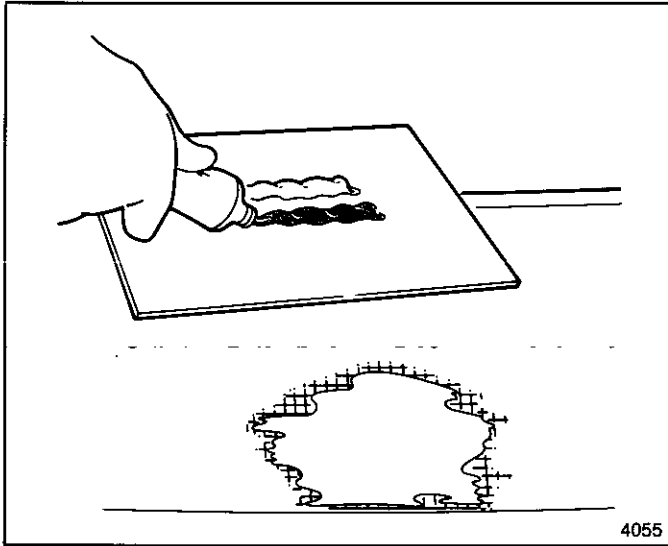

Fig. 1-14-Measuring Two-Component Repair Material

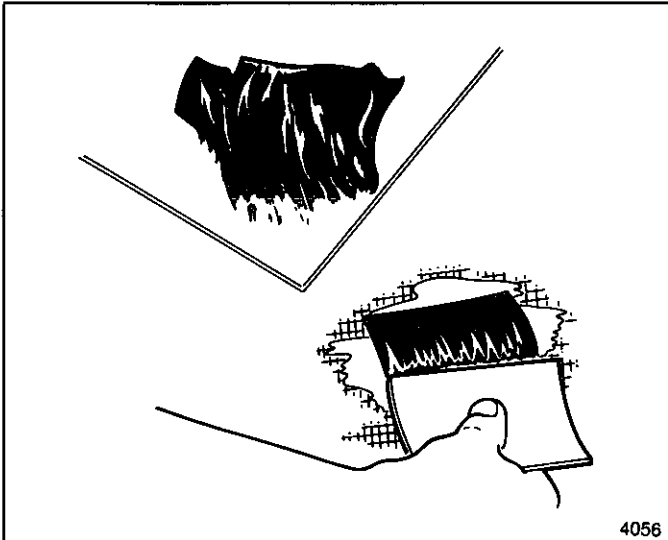

Fig. 1-15-Applying Mixed Repair Material

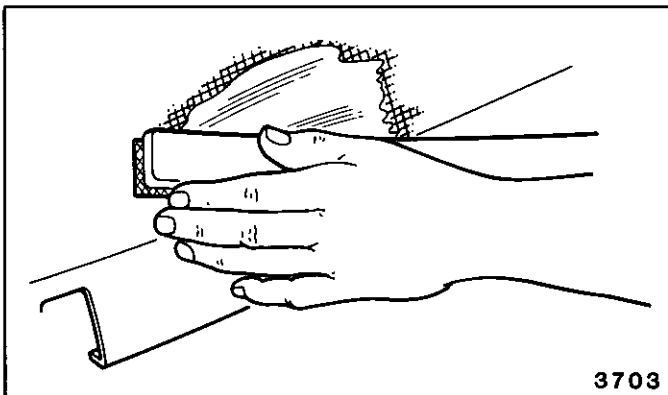

Fig. 1-16-Establishing Rough Contour with Body File

For final feathering, use a random orbit sander with a #320 disc.

### 2. Structural type repair

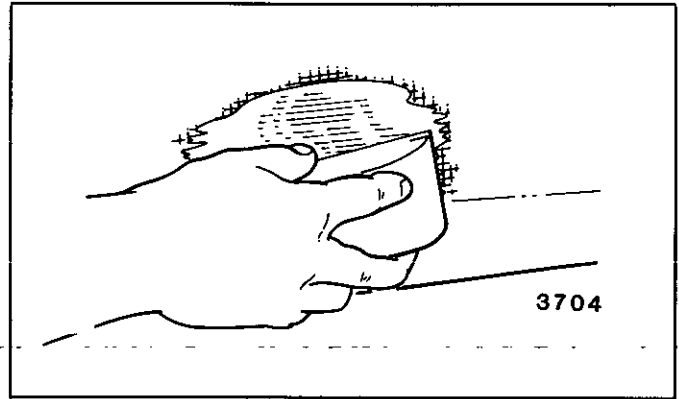

Fig 1-17-Block Sanding for Accurate Contour

- Align and secure the piece on the face side with body tape and clamp (Fig. 1-19).
- Clean the underside of the repair area as in step 1a. Sand each side of the break with a #50 grit disc. (Fig. 1-20).
- Cut a piece of fiberglass cloth large enough to overlap the break 38 mm (1-1/2") as in Figure 1-21.
- As in step 1c, thoroughly mix a quantity of adhesive and apply a layer of the mixture approximately 3 mm (1/8" thick on the back side of the part overlapping the break at least 38 mm (1-1/2") as in Figure 1-22.

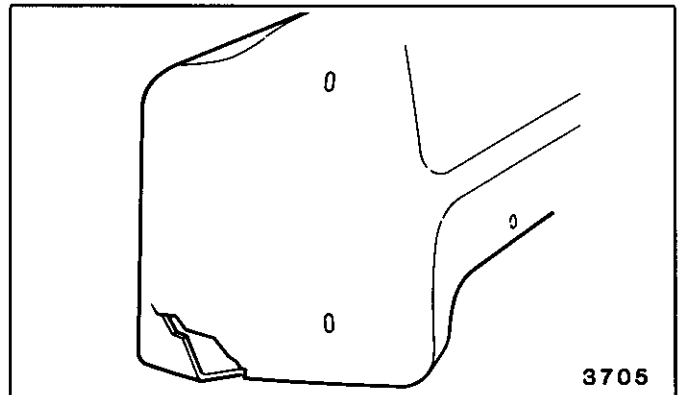

Fig. 1-18-Damaged Attaching Surface

- Apply the precut fiberglass cloth to the adhesive and immediately cover the cloth with additional adhesive in sufficient quantity to fill the weave (Figs. 1-23 and 1-24).
- Allow 20-30 minutes cure time at 16 to 27°C (60 to 80°F). Trim excess repair material at edge if necessary.
- Repair the face side of the area following steps 1a through 1e.

## PAINTING OF EXTERIOR PANELS

The original factory applied paint finish consists of a base coat-clear coat enamel paint. For paint repair, you may use either enamel or lacquer paint. Follow the

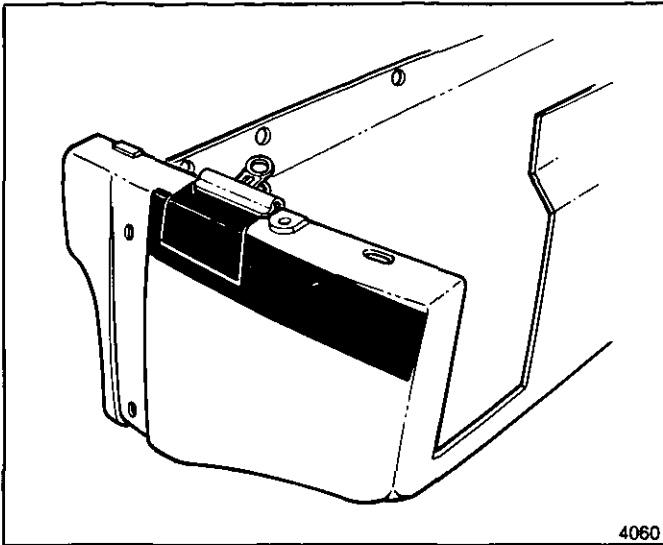

Fig. 1-19-Aligning Damage with Tape and Clamp

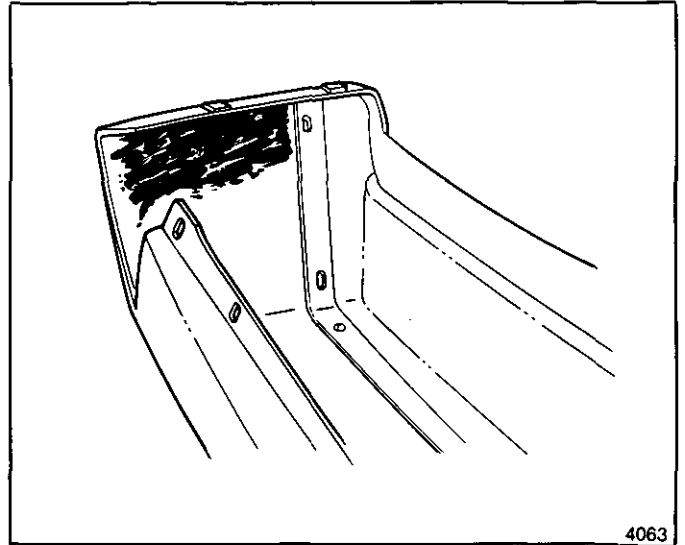

Fig. 1-22-Applying Repair Material - Back Side of Damage

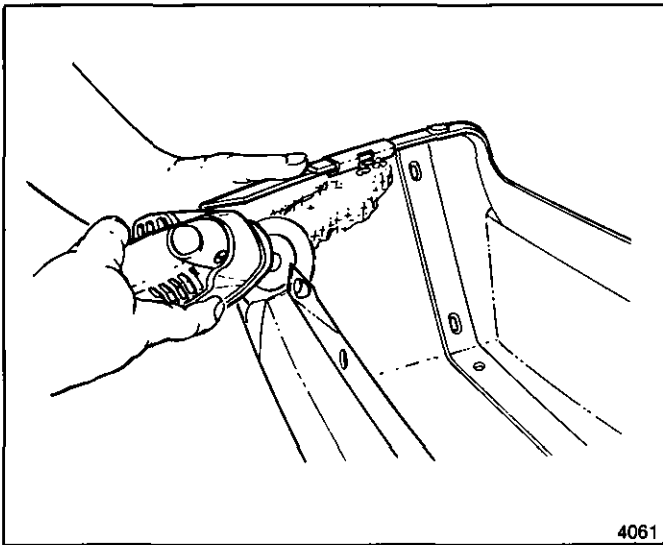

Fig. 1-20-Discing Back Side of Damage

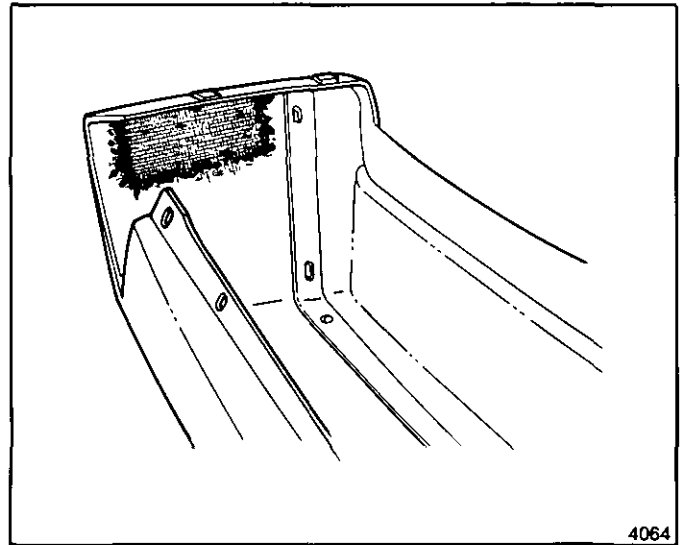

Fig. 1-23-Applying Fiberglass Cloth to Repair Material

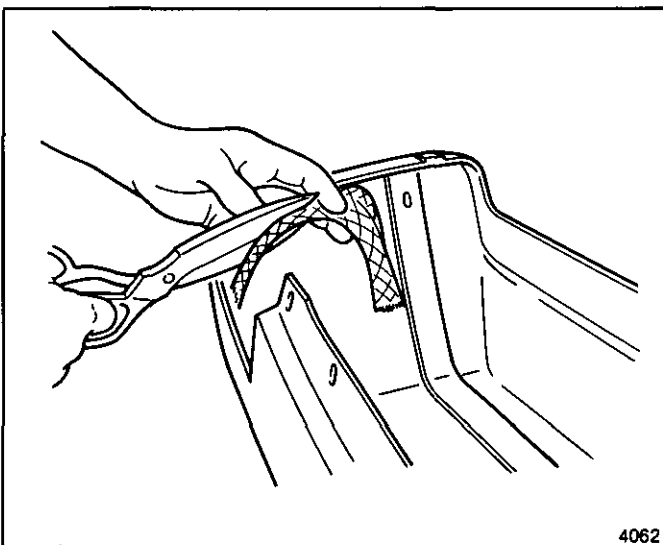

Fig. 1-21-Cutting Fiberglass Cloth to Size

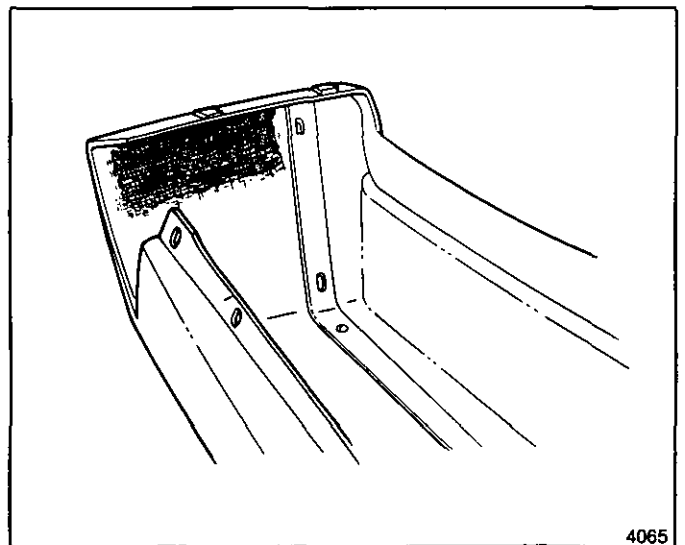

Fig. 1-24-Filling Fiberglass Cloth

There is a wide choice of flexible paint systems available for service use, however, many require

additives containing isocyanates. Be certain to follow the manufacturer's recommendations. Procedures and

warnings listed on the container are provided with the material selected.

**CAUTION:** If the paint system selected specifies an additive containing isocyanates, it is mandatory that a Willson Paint Spray Respirator No. 122115 with R21 cartridge and R15 filter, or 3M Spray Paint Respirator No. 6984 (or equivalent) be worn during the entire painting process. Persons with respiratory problems or those allergic to isocyanates must not be exposed to the isocyanate vapors or spray mist.

When using a flexible paint system, color coat the entire panel. Spot repair is not recommended.

When painting flexible plastic exterior parts identified as TPO, use a polypropylene primer. Follow manufacturer's label instructions.

### INTERIOR PLASTIC TRIM AND PARTS FINISHING

Paintable plastic interior trim components can be divided into three general types:

1. Polypropylene Plastic
2. ABS Plastic
3. Vinyl Plastic

It is important for a painter to be able to identify each plastic in order to paint it satisfactorily. Painting of complete soft seat cushion and seatback trim cover assemblies of vinyl construction is not approved by the factory. Excluding the soft seat cushion and seatback trim cover assemblies, the plastic used most widely on the interior of bodies is polypropylene.

### TESTS FOR PLASTIC IDENTIFICATION

The purpose of the following tests is to determine the identity of a given plastic so that proper paint procedures and materials can be used.

#### TEST FOR POLYPROPYLENE AND ABS PLASTIC

To determine if a service part to be painted is polypropylene or ABS plastic, perform the following burn test:

1. From a hidden backside portion of the part, remove a sliver of plastic with a sharp blade.
2. While holding the sliver of plastic with tweezers or laying it on a clean noncombustible surface, ignite the plastic.
3. Observe the burning plastic closely:
  - Polypropylene burns with no readily visible smoke.
  - ABS plastic burns with a readily visible black smoke residue which hangs temporarily in the air.

#### TEST FOR VINYL PLASTIC

1. Heat a copper wire in a suitable flame such as provided by a propane or equivalent torch until the wire glows (turns red).
2. Touch the heated wire to the backside or hidden surface of the part being tested in a manner so as to retain some of the plastic on the wire.
3. Return the wire (and retained plastic) to the flame and observe for a green, turquoise blue flame. A flame in this color range indicates that the plastic being tested is vinyl.
4. If black smoke residue, which hangs temporarily in the air, is readily visible when wire (with retained plastic residue) is returned to the flame, the part is made of flexible (soft) ABS plastic material.

### PAINTING POLYPROPYLENE PLASTIC PARTS

The system for painting polypropylene parts involves the use of a special primer. Since polypropylene plastic is hard, it can be color coated after prime with conventional interior acrylic lacquer.

**NOTICE:** Service part must be primed with a coating of special polypropylene primer according to factory recommendations. Failure to use the required primer as directed will result in color coat lifting and/or peeling problems. Use polypropylene primer, part no. 1052364 (or equivalent).

1. Wash part with a solvent, such as Acryli-Clean, Pre-Kleano, Prep-Sol (or equivalent). Follow label directions.
2. Apply a thin, wet coat of polypropylene primer according to label directions. Wetness of primer is determined by observing gloss reflection of spray application in adequate lighting. Be sure primer application includes all edges. Allow primer to flash dry one minute minimum and ten minutes maximum.
3. During the above flash time period (1 to 10 minutes), apply conventional interior acrylic lacquer color as required and allow to dry before installing part. Application of color during above flash time range promotes best adhesion of color coats.

### PAINTING RIGID OR HARD ABS PLASTIC PARTS

Rigid or hard ABS plastic requires no primer. Conventional interior acrylic lacquers adhere satisfactorily to hard ABS plastics.

1. Wash part with a solvent such as Acryli-Clean, Pre-Kleano, Prep-Sol (or equivalent).
2. Apply conventional interior acrylic lacquer color according to trim combination (see paint supplier color chart for trim and color code). Apply only enough color for proper hiding to avoid washout of grain effect.

## PAINTING VINYL AND FLEXIBLE (SOFT) ABS PLASTIC PARTS

The outer cover material of flexible instrument panel cover assemblies is made mostly of ABS plastic modified with PVC or vinyl. The same is true of many padded door trim assemblies. The soft cushion padding under ABS covers is urethane foam plastic.

The most widely used flexible vinyls (polyvinyl chloride) are coated fabrics as used in seat trim, some door trim assemblies, headlinings and sunshades. Examples of hard vinyls are door and front seatback assist handles, coat hooks and exterior molding inserts.

The paint system for vinyl and flexible ABS plastic involves the use of interior vinyl color and a clear vinyl top coat. No primer or primer-sealer is required.

1. Wash part with a vinyl cleaning and preparation solvent, such as Vinyl Prep, Vinyl Prep Conditioner (or equivalent). Wipe off cleaner while still wet with a clean, lint-free cloth.
2. As soon as the surface has been wiped dry, apply interior vinyl color in wet coats. Allow flash time between coats according to label directions. Use proper vinyl color shown by interior trim code combination. Apply only enough color for proper hiding to avoid washout of grain effect.
3. Before color flashes completely, apply one wet double coat of vinyl clear top coat. Use top coat with appropriate gloss level to match adjacent similar components. The clear coat is necessary to control the gloss requirement and to prevent crocking (rubbing-off) of the color coat after drying.
4. Allow to dry according to label directions before installing part.

## AVAILABILITY OF COLORS FOR PAINTING INTERIOR PLASTIC PARTS

Interior colors are color keyed to trim combination numbers located on the body number plate.

Conventional interior acrylic lacquer colors are designed for use only on hard trim parts, such as:

1. Steel parts (primer or sealer required on new service parts).
2. Hard ABS plastic (no primer necessary).
3. Hard polypropylene plastic (special primer required).

Each major paint supplier provides an interior color chart which identifies the stock number, color name, gloss factor and trim combination number for each conventional interior color.

Vinyl interior colors are designed for soft trim parts such as instrument panel cover assemblies and door trim assemblies. These colors require a final top coat of clear vinyl. Instrument panel covers require a nonglare final top coat. Other trim parts require a degree of gloss to match similar adjacent parts. Use interior vinyl colors and clear vinyl finishes such as Ditzler Vinyl Spray Colors, American Jetway UR-1 Vynicolor (or equivalent.)

## SPECIAL BODY TOOLS

Figure 1-25 shows special body tools that are recommended as aids in servicing the various body components. Equivalent tools may be substituted.

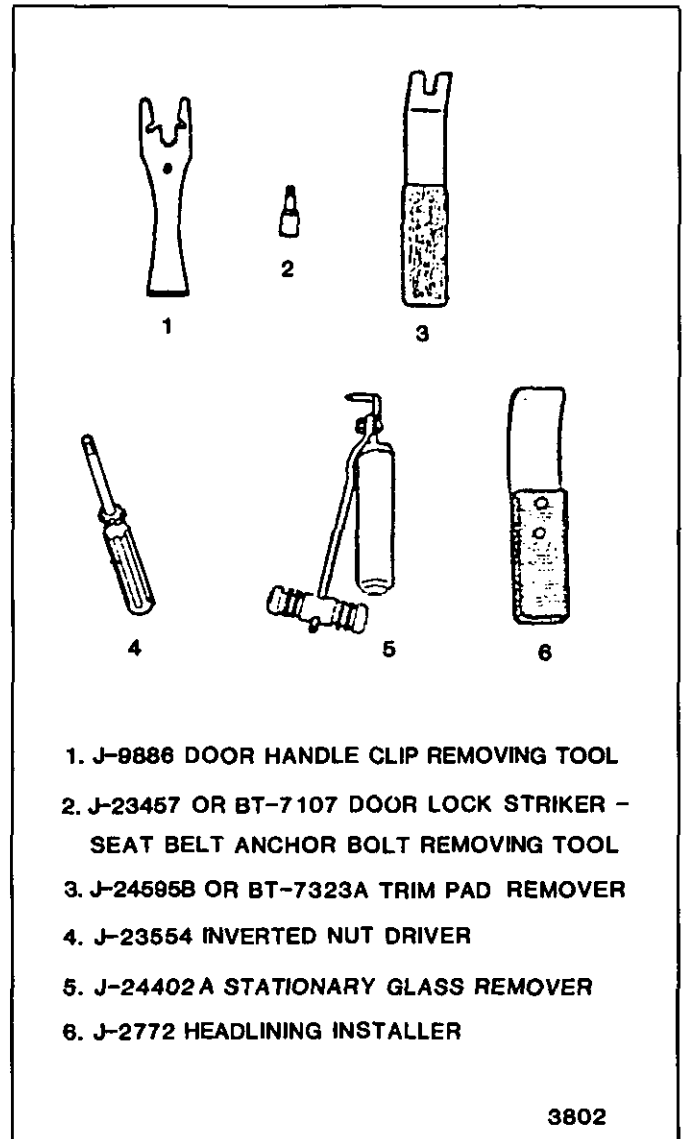
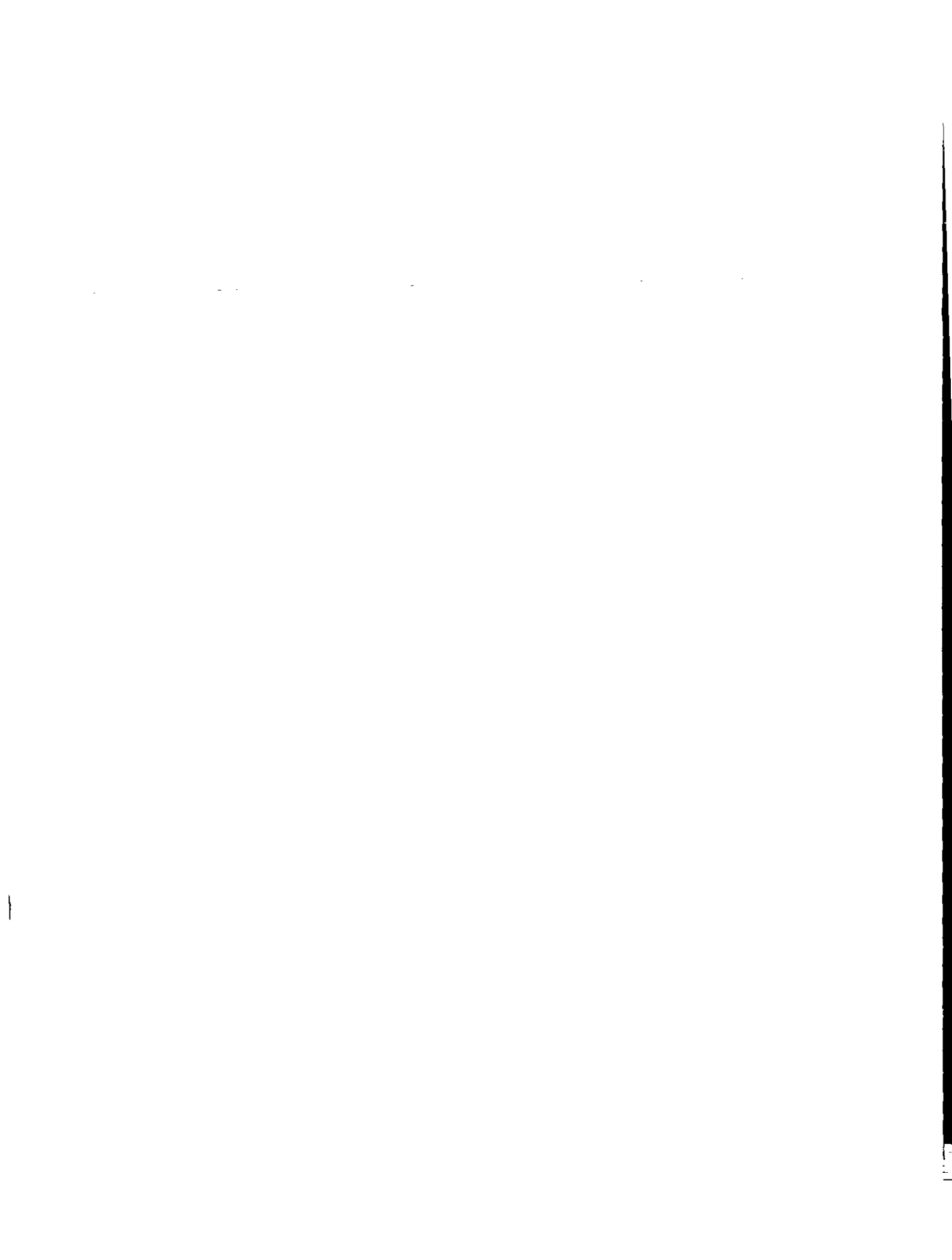

Fig. 1-25-Special Body Tools



# SECTION 3

# UNDERBODY

## CONTENTS

Underbody ..... 3-1 General Body Construction and Alignment ..... 3-1 Alignment Checking ..... 3-1 Floor Pan Insulators ..... 3-1	Seatback to Motor Compartment Panel ..... 3-1 Lower Garnish Moldings ..... 3-2 Floor Carpets ..... 3-2
---	---

### UNDERBODY

#### GENERAL BODY CONSTRUCTION AND ALIGNMENT

Information in this section pertains to unitized construction of the space frame. The space frame incorporates integral front and rear frame side rails which support the body components, front and rear suspension systems and other mechanical components.

The front suspension system and rack and pinion steering mount assemblies are attached to a front suspension cross member. The cross member is bolted to the front frame side rails. These components must be dimensionally correct in relation to the remainder of the underbody in order to maintain specified caster and camber angles.

Mounting provisions for the rear suspension system are shared by chassis components (suspension lower control arms and engine cradle) and body components (*rear frame side rails and suspension strut towers*). The suspension strut towers are part of the engine compartment side panels. They must be dimensionally correct in relation to the remainder of the underbody in order to maintain correct engine cradle and rear wheel alignment.

Unitized construction demands that underbody components be aligned properly to assure correct suspension location. In the event of collision damage, it is important that the underbody be thoroughly checked and, if necessary, realigned in order to establish proper dimensions.

Since each individual underbody component contributes directly to the overall strength of the body, it is essential that proper welding, sealing and rustproofing techniques be observed during service operations. Underbody components should be rustproofed whenever body repair operations which destroy or damage the original rustproofing, are completed. When rustproofing critical underbody components, it is essential that a good quality type of air dry primer be used (such as corrosion resistant chromate or equivalent material). It is not advisable to use combination type primer-surfacers.

There are many tools that may be used to correct the average collision damage situation including frame straightening machines, lighter external pulling equipment and standard body jacks.

#### ALIGNMENT CHECKING

An accurate method of determining the alignment of the underbody utilizes a measuring tram gage. The tram gage required to perform all recommended measuring checks properly must be capable of extending to a length of 2 286 mm (90"). The vertical pointers must be capable of a maximum reach of 500 mm (19-11/16").

Dimensional checks are made using a horizontal reference plane (datum line) parallel to the plane of the underbody. Precision measurements can be made only if the tram gage is parallel to the plane. This can be controlled by setting the vertical pointers to the correct height as shown in Figures 3-5 and 3-9.

A proper tramming tool is essential for analyzing and determining the extent of collision misalignment present in underbody construction.

To assist in checking alignment of the underbody components, repairing minor underbody damage or locating replacement parts, refer to Figures 3-4 through 3-9.

Dimensions to gage holes are measured to center of the holes and flush to adjacent surface metal unless otherwise specified.

#### FLOOR PAN INSULATORS

Floor pan insulators are a 10 mm (3/8") thick amberlite material which is composed of resinated fibers. The floor pan insulators are molded pieces and are adhered to the back side of the floor carpet and seatback-to-motor compartment panel. These insulators are only serviceable as a part of the floor carpet and seatback-to-motor compartment panel, and must meet Motor Vehicle Safety Standard No. 302 for flammability.

#### SEATBACK-TO-MOTOR COMPARTMENT PANEL

The seatback-to-motor compartment panel is a molded plastic panel with an amberlite insulator attached to the back side of the panel.

#### Remove or Disconnect (Figure 3-1)

1. Rear quarter trim panels. Refer to Section 6.
2. Console shifter plate assembly. Refer to the appropriate section in the chassis portion of this manual.

## 3-2 UNDERBODY

3. Rear console pad assembly. Refer to the appropriate section in the chassis portion of this manual.
4. Three screws (3)
5. Seatback-to-motor compartment panel (1). Carefully pry fasteners (3) from retainers (4)

### ↔ Install or Connect (Figure 3-1)

1. Seatback-to-motor compartment panel (1)
2. Three screws (3)
3. Rear console pad assembly. Refer to the appropriate section in the chassis portion of this manual.
4. Console shifter plate assembly. Refer to the appropriate section in the chassis portion of this manual.
5. Rear quarter trim panels. Refer to Section 6.

## LOWER GARNISH MOLDINGS

### ↔ Remove or Disconnect (Figure 3-2)

1. Five garnish molding plugs (7)
2. Five garnish molding screws (6)
3. Lower garnish molding (5). Pull upward and out at rear of garnish molding (5) to disengage from upper garnish molding (8).

### ↔ Install or Connect (Figure 3-2)

1. Lower garnish molding (5)

2. Five garnish molding screws (6)
3. Five garnish molding plugs (7)

## FLOOR CARPETS

The floor carpet consists of molded right and left side carpet assemblies. Floor pan insulators are attached to the floor carpet assemblies. The right and left side floor carpets may be serviced separately.

### ↔ Remove or Disconnect (Figures 3-1, 3-2 and 3-3)

1. Seats(s), refer to Section 9.
2. Seatback-to-motor compartment panel (1)
3. Front console pad. Refer to the appropriate section in the chassis portion of this manual.
4. Lower garnish molding(s) (5)
5. Inboard seat belt(s). Refer to Section 9.
6. Carpet(s) (9). Disengage carpet from retainers (10) in console (11). There are six retainers per side.

### ↔ Install or Connect (Figures 3-1, 3-2 and 3-3)

1. Carpet(s) (9)
2. Inboard seat belt(s). Refer to Section 9.
3. Lower garnish molding(s) (5)
4. Front console pad. Refer to the appropriate section in the chassis portion of this manual.
5. Seatback-to-motor compartment panel (1)
6. Seat(s), refer to Section 9.

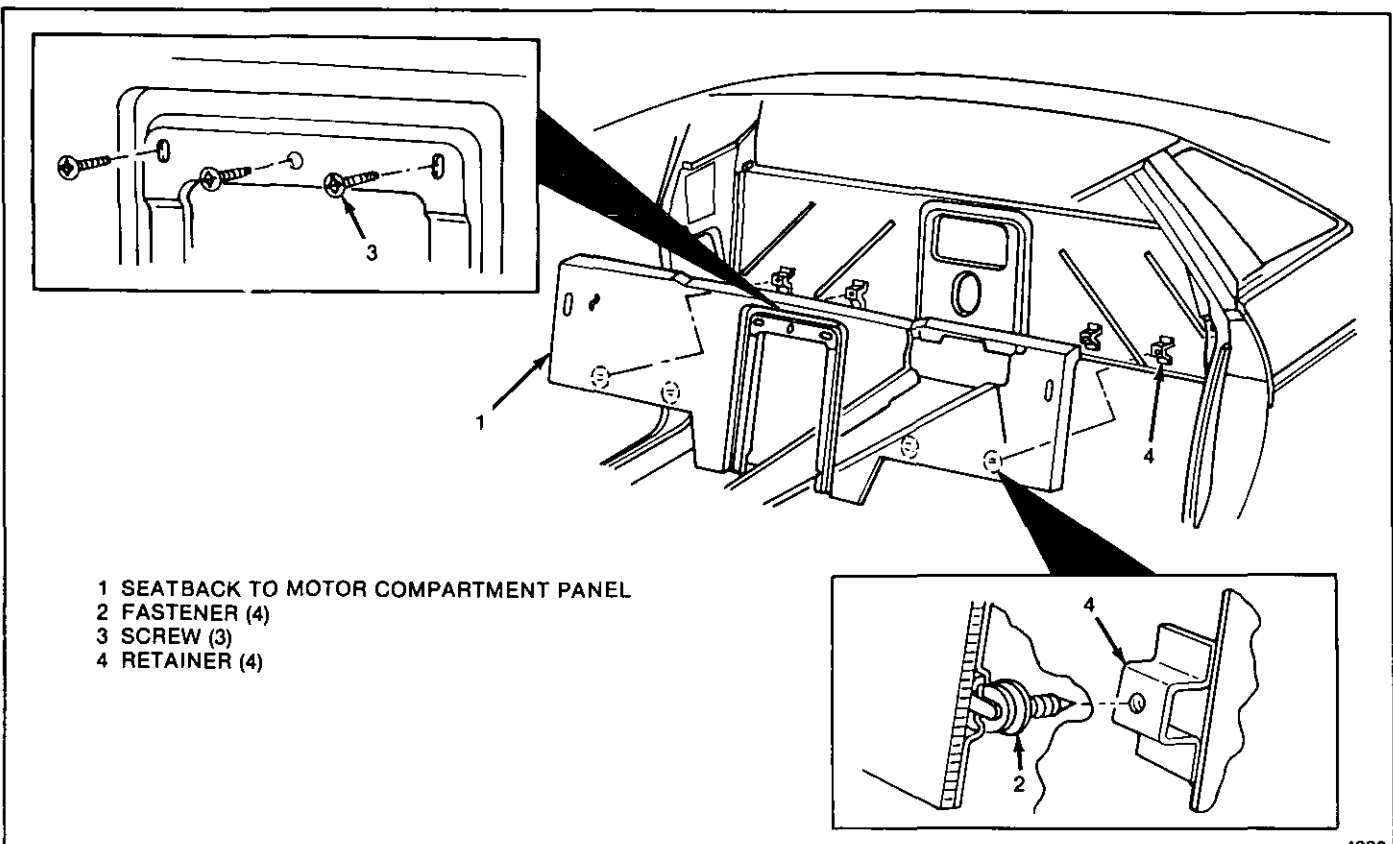



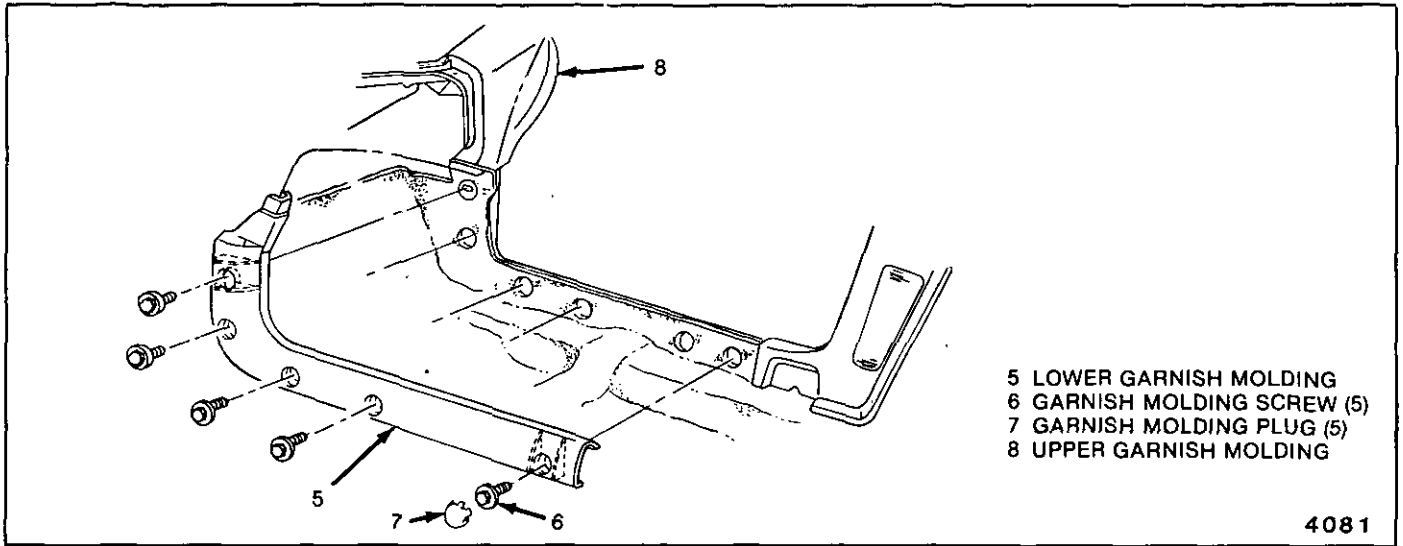

Fig. 3-2-Installing Lower Garnish Molding

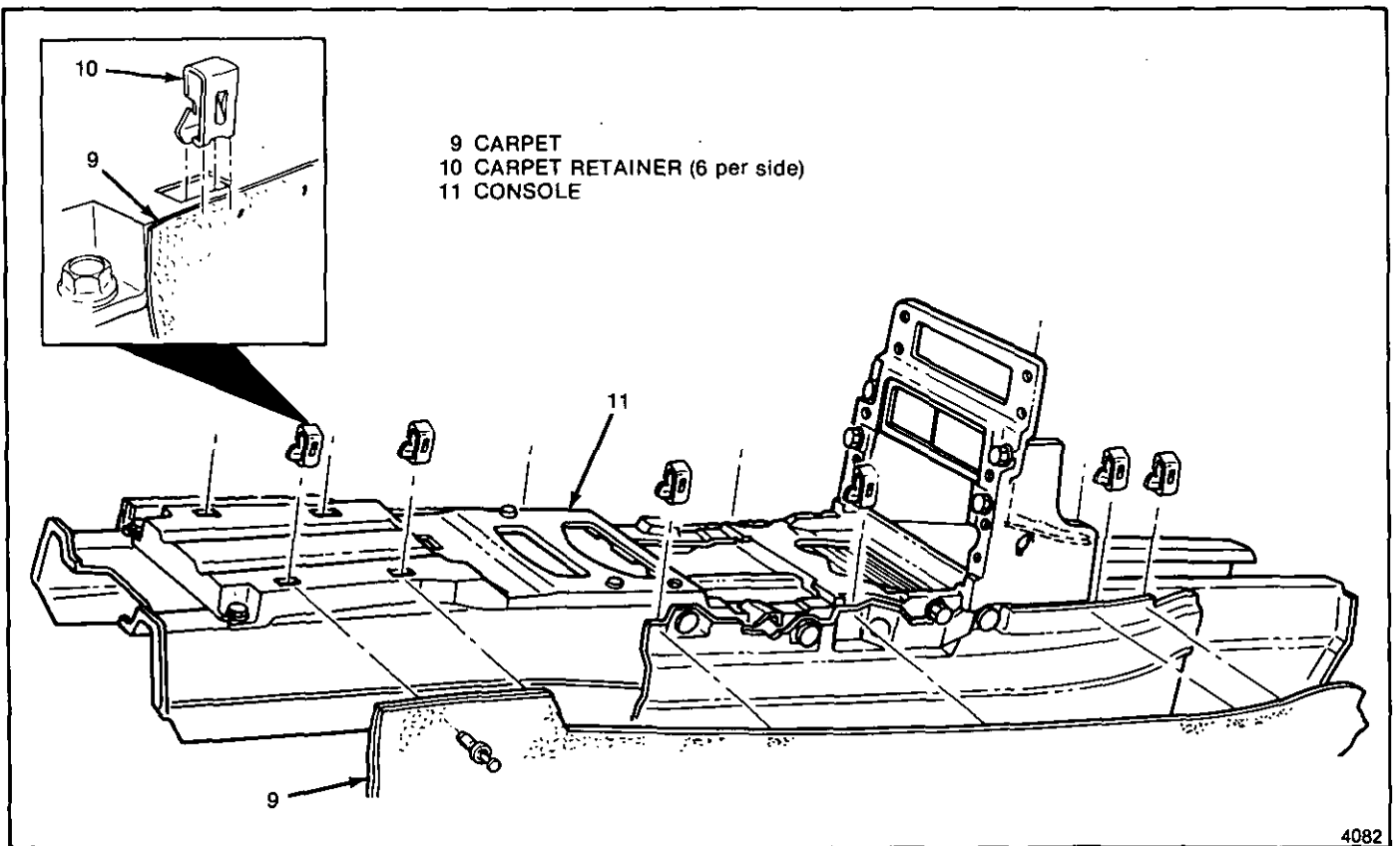
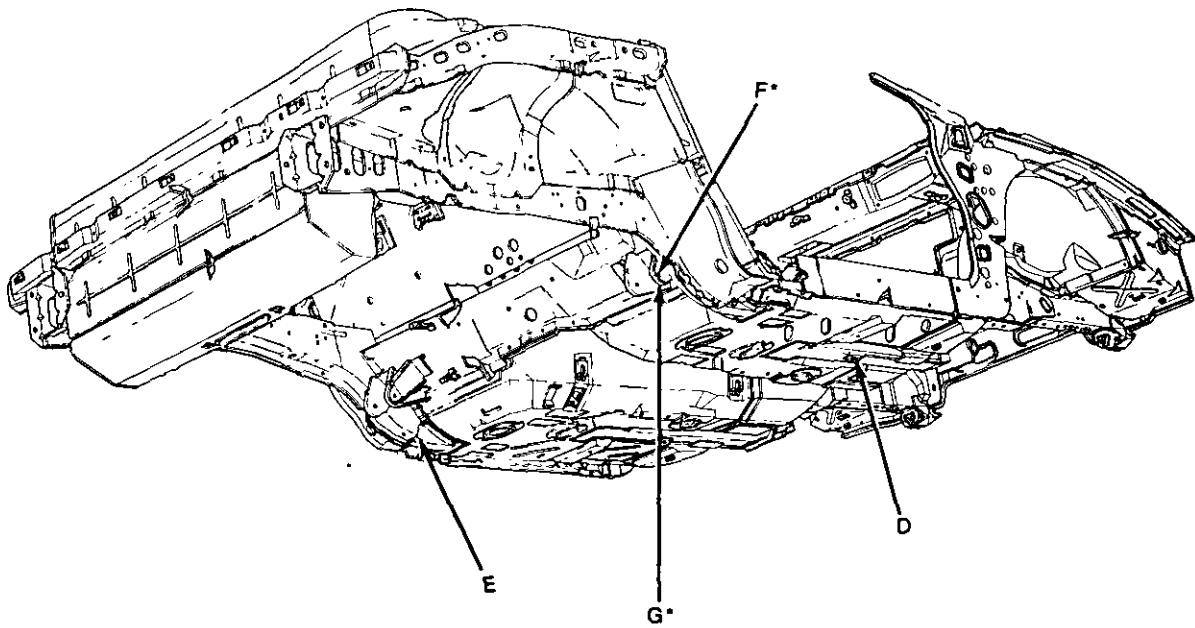
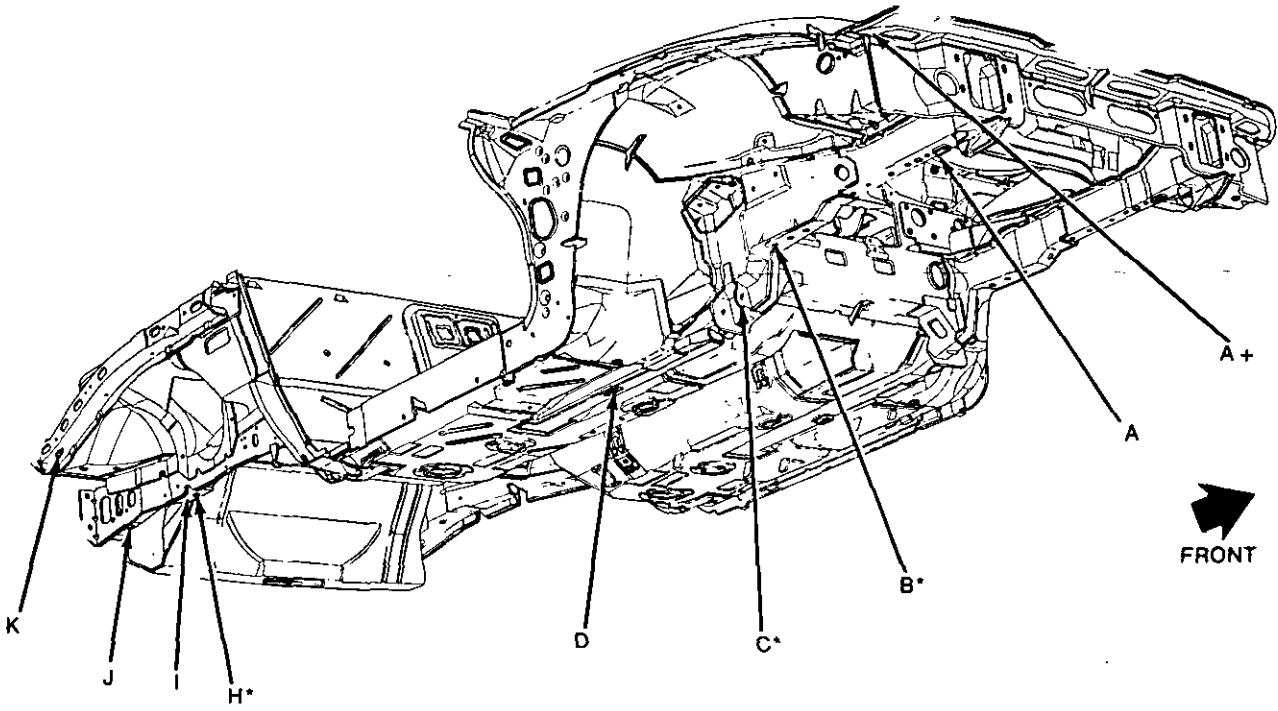

Fig. 3-3-Installing Carpet to Console



\*MEASURE WITH BOLT INSTALLED

FIG. 3-4 Wheel Stance, Roll Over, Frame Dimensions

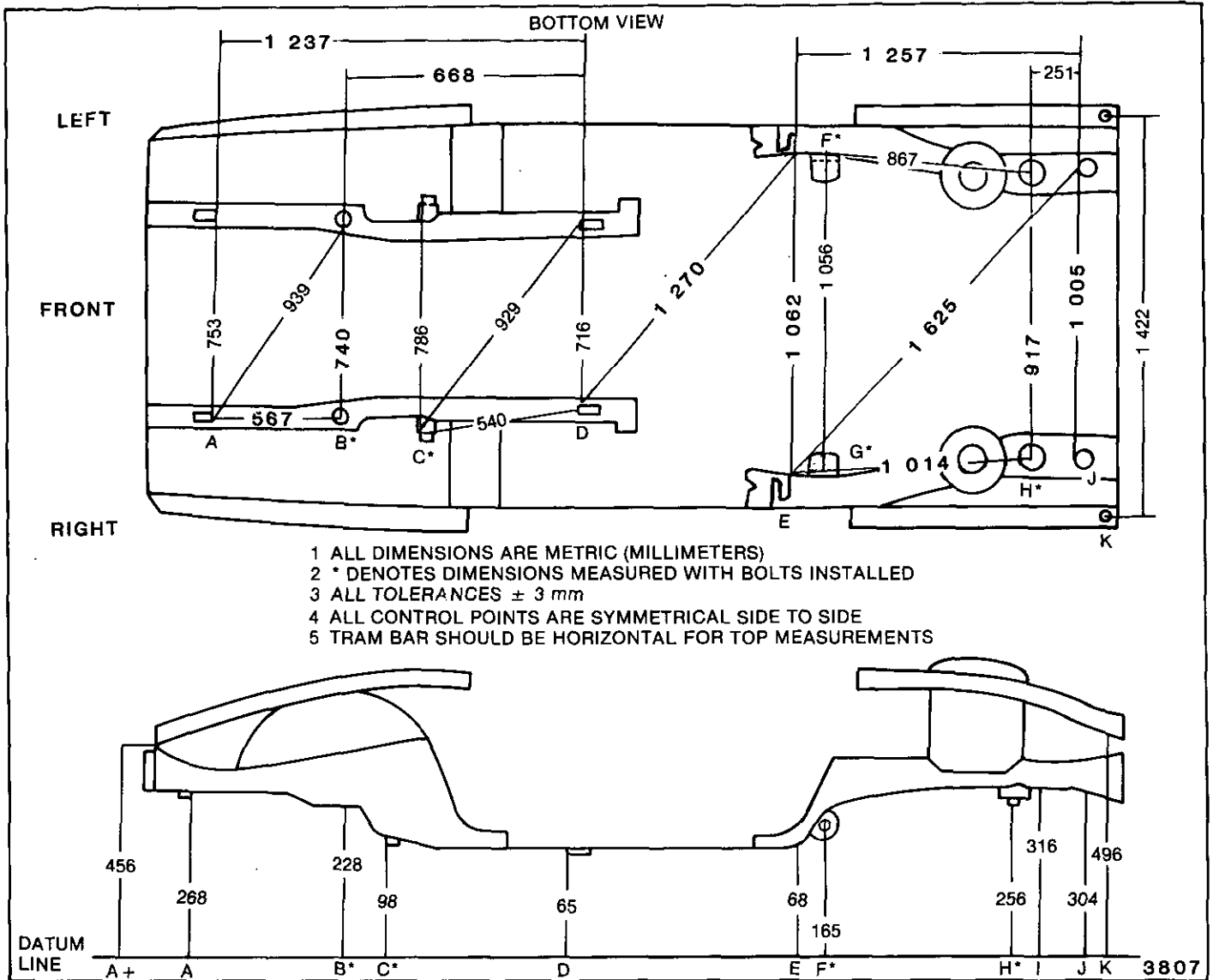

Fig. 3-5-Horizontal and Vertical Dimensions

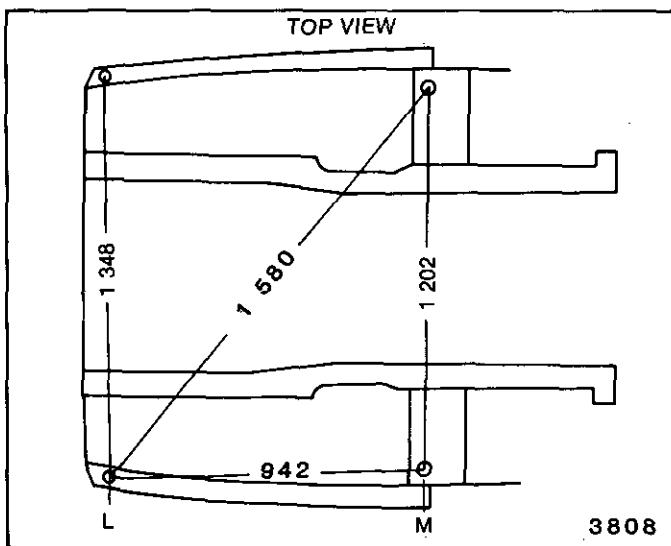

Fig. 3-6-Front Compartment Upper Side Rail Dimensions

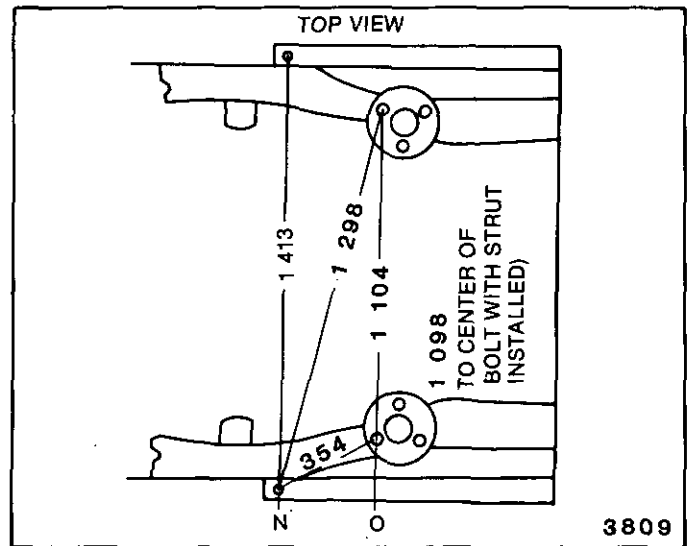

Fig. 3-7-Rear Compartment Upper Side Rail and Suspension Strut Tower Dimensions

### 3-6 UNDERBODY

REFERENCE	HORIZONTAL	VERTICAL	LOCATION
A +	NONE	Lower surface of front side rail relief notch	Lower surface of front side rail
A	Trailing edge of rectangular hole on center	Lower edge of flange on front compartment lower outer side rail	Lower front compartment outer side rail
B	Center of front suspension crossmember rear mounting bolt (bolt installed)	Center of front suspension crossmember rear mounting bolt (bolt installed)	Front suspension crossmember to lower front compartment outer side rail rear attachment
C	Lower edge of forward flange in line with center of mounting bolt (bolt installed)	Lower edge of forward flange in line with center of mounting bolt (bolt installed)	Forward flange of lower control arm mounting bracket
D	Leading edge of rectangular hole on center	Lower edge of flange on front compartment lower inner side rail	Lower front compartment rear inner side rail
E	Inboard corner at midpoint of radius of lap joint	Inboard corner surface of motor compartment rail	Lap joint between motor compartment rail and rail extension to floor pan
F	Center of front outboard cradle attaching bolt	Center of front outboard cradle attaching bolt	Motor compartment front cradle mounting bracket
G	Inboard side of front cradle mounting bracket outboard flange where bend begins	NONE	Motor compartment front cradle mounting bracket
H	Center of rear cradle attaching bolt (bolt installed)	Center of rear cradle attaching bolt (bolt installed)	Rear engine cradle attaching location
I	NONE	Lower surface of engine cradle	Lower surface of engine cradle at cradle attaching location
J	Leading edge of 20 mm flanged hole on center	Leading edge of 20 mm flanged hole on center	Lower surface of motor compartment lower side rail
K	Center of 12 mm hole	Center of 12 mm hole	Lower surface of motor compartment upper side rail
L	Center of 10 mm hole	NONE	Front upper surface of front compartment upper side rail
M	Center of 9 mm threaded hole	NONE	Cowl panel hood restraint bolt holes
N	Center of 5 mm hole in mounting pad for forward rear compartment side rail extension bolt	NONE	Motor compartment upper side rail
O	Center of suspension strut tower forward attaching hole	NONE	Motor compartment suspension strut tower

DIMENSION	METRIC (MILLIMETERS)	ENGLISH (INCHES)
<b>HORIZONTAL</b>		
A to A	753	29-5/8
A to B	567	22-5/16
A to D	1 237	48-11/16
B to A	939	36-15/16
B to B	740	29-1/8
B to D	668	26-5/16
C to C	786	30-15/16
C to D	540	21-1/4
D to C	929	36-9/16
D to D	716	28-3/16
E to D	1 270	50
E to E	1 062	41-13/16
E to H	1 014	39-15/16
E to J	1 257	49-1/2
F to H	867	34-1/8
G to G	1 056	41-9/16
H to H	917	36-1/8
H to J	251	9-7/8
J to J	1 005	39-9/16
J to E	1 625	64
K to K	1 422	56
L to L	1 348	53-1/16
L to M	942	37-1/16
M to M	1 202	47-5/16
M to L	1 580	62-3/16
N to N	1 413	55-5/8
N to O	354	13-15/16
O to O	1 104	43-7/16
O to N	1 298	51-1/8
<b>VERTICAL</b>		
A+	456	17-15/16
A	268	10-9/16
B	228	9
C	98	3-7/8
D	65	2-9/16
E	68	2-11/16
F	165	6-1/2
H	256	10-1/16
I	316	12-7/16
J	304	12
K	496	19-1/2

Fig. 3-9-Metric-to-English Dimension Conversion Chart

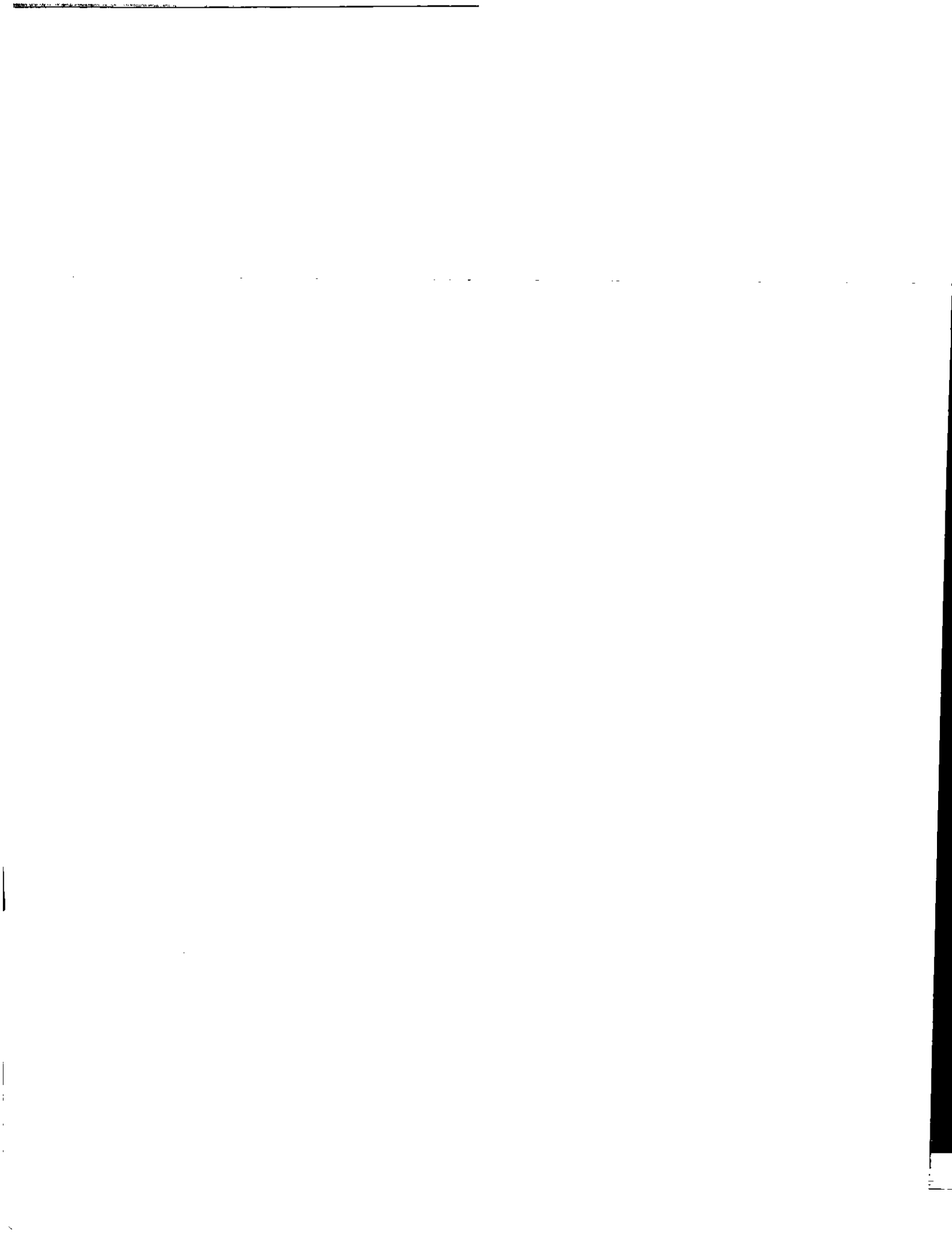

## SECTION 4

# FRONT END

**NOTICE:** Care must be taken when servicing any fiberglass (SMC) panel or component. Fasteners retaining such panels or components must be hand started to prevent damage to fiberglass parts. Always use the specified torque values given for SMC parts to assure safe and proper retention.

## CONTENTS

Front End .....	4-1	Hood Hinge .....	4-3
Body Ventilation .....	4-1	Hood Latch .....	4-3
Top Shroud Vent Duct Screen .....	4-1	Striker .....	4-4
Water Deflectors .....	4-1	Hood Ajar Switch .....	4-4
Front End Sealing .....	4-1	Front Compartment Weatherstrip .....	4-4
Headlamp Door Assembly .....	4-1	Glass Roof Vent Storage Cover .....	4-4
Headlamp Cover Panel .....	4-1	Fender Panel .....	4-4
Filler Assembly .....	4-3	Front Wheelhouse Panel .....	4-6
Hinge Assembly .....	4-3	Grille Assembly .....	4-6
Hood Assembly .....	4-3	Front Fascia .....	4-6
Hood Alignment .....	4-3	Molding .....	4-8

### FRONT END

#### BODY VENTILATION

The body ventilation system on vehicles without air conditioning consists of two fresh air ducts under the shroud screen. Air enters the front plenum chamber through the shroud screen and is directed through the chambers to the outlet doors. When the outlet doors are opened, air flows into the passenger compartment and is expelled through the pressure relief valve located in the body lock pillar under the quarter applique panel.

#### Top Shroud Vent Duct Screen

##### Remove or Disconnect (Figure 1)

1. Windshield wiper arm assemblies
2. Attaching screws (2)
3. Fasteners (3) two required
4. Rivet (4) using a 6.3 mm (1/4") drill bit
5. Spring (5)
6. Windshield washer hoses as required
7. Screen (1) by lifting up on screen to disengage fasteners (6) from holes in plenum chamber

##### Install or Connect (Figure 1)

1. Screen (1) to body by locating fasteners (6) over holes in plenum chamber and pushing down on screen
2. Hoses
3. Spring (5)
4. Rivet (4) using part no. 20421672 or equivalent
5. Fasteners (3)
6. Screws (2)
7. Windshield wiper arm assemblies

#### WATER DEFLECTORS

Water deflectors are located within the plenum chamber and are an integral part of it. Along with the top shroud vent screen, these deflectors prevent water from entering the air inlet into the passenger compartment.

#### FRONT END SEALING

All potential waterleak locations are sealed in production with high quality durable sealers. Should it be necessary to reseal specific areas, a high quality medium-bodied sealer which will remain flexible after curing and can be painted should be used.

#### HEADLAMP DOOR ASSEMBLY

The headlamp doors have slotted mounting points which insures proper clearance between the headlamp door and the hood. The entire headlamp door assembly can be adjusted to achieve the desired appearance and fit. Care should be exercised when adjusting the headlamp door assembly so as not to damage any components.

#### Headlamp Cover Panel

##### Remove or Disconnect (Figure 2)

1. Retainer (16)
2. Cover (13)
  - Hold assembly open
  - Lift rear and slide cover forward

##### Install or Connect (Figure 2)

1. Cover (13)
2. Retainer (16)

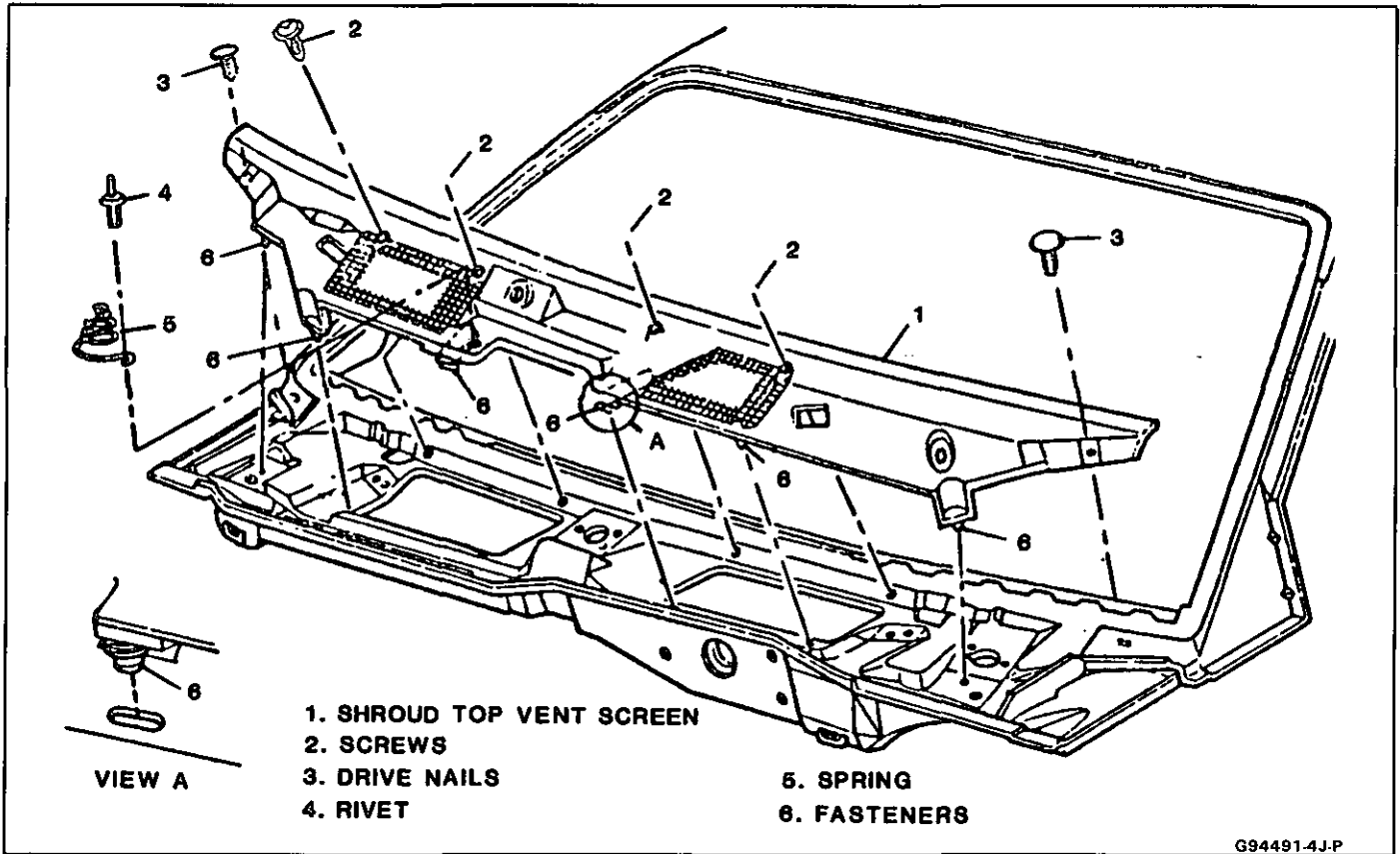

Fig. 1-Installing Cowl Vent System

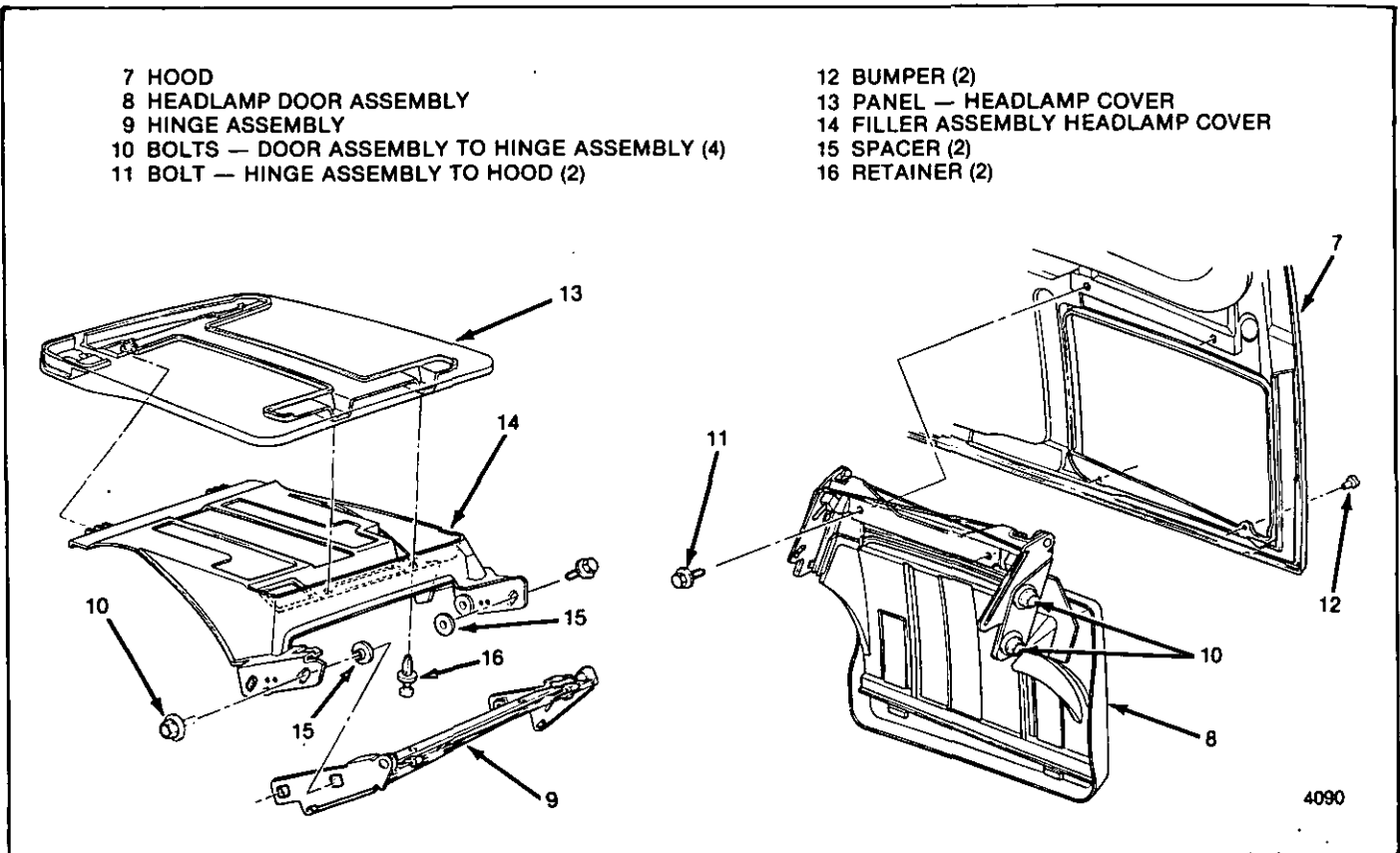

Fig. 2-Headlamp Door Assembly



## Filler Assembly

### Remove or Disconnect (Figure 2)

1. Bolts (10)
2. Cover (13) and filler (14) assembly
3. Cover (13)

### Install or Connect (Figure 2)

1. Cover (13)
2. Cover (13) and filler (14) assembly
3. Bolts (10)

## Hinge Assembly

### Remove or Disconnect (Figure 2)

1. Bolts (11)
2. Door assembly (8)
3. Bolts (10)
4. Hinge (9)

### Install or Connect (Figure 2)

1. Hinge (9)
2. Bolts (10)
3. Door assembly (8)
4. Bolts (11)

### Adjust (Figure 2)

## Front and Rear Gap Adjustment

1. Loosen four bolts (10)
2. Align as necessary
3. Tighten four bolts (10)

## Side-to-Side Gap Adjustment

1. Loosen two bolts (11)
2. Align as necessary
3. Tighten two bolts (11)

## HOOD ASSEMBLY

The hood is composed of a single outer panel and an inner reinforcement. Both panels are composed of fiberglass.

### Remove or Disconnect (Figure 3)

1. Bolts – two upper support attaching (19)
2. Nuts – hinge to body (23)
3. Hood (17)

### Install or Connect (Figure 3)

1. Hood (17)
2. Nuts – hinge to body (23)
3. Bolts – two upper support attaching (19)

### Inspect

For proper operation and alignment

## Hood Alignment

Slotted holes are provided at all hood hinge attaching points for proper adjustment – both vertically and fore and aft. For best results, make one adjustment at a time. The following lists conditions that may be encountered. It gives the components that will need adjustment to correct the condition. One or more of the conditions may be encountered. Make adjustments only as required to correct the condition.

### Adjust (Figure 3)

- Hood too high or low at front corners
  - Loosen nuts (23)
  - Reposition hood assembly
  - Tighten nuts (23)
- Hood too high or low at rear corners
  - Determine amount and direction of adjustment needed
  - Adjust hood bumper accordingly
- Hood too far fore or aft
  - Loosen bolts (22)
  - Reposition hood assembly
  - Tighten bolts (22)

## Hood Hinge

### Remove or Disconnect (Figure 3)

### Important

Scribe line around hinge on hood inner panel and front panel to indicate original hinge position.

1. Block hood and prop open on side to be removed
2. Nuts (23)
3. Bolts (22)
4. Hinge (21)

### Install or Connect (Figure 3)

1. Hinge (21) align with scribe marks
2. Bolts (22)
3. Nuts (23)

### Inspect

Close hood carefully and check for proper alignment.

## Hood Latch

The hood latch is a cable released, positive locking assembly located in the center section of the cowl. It is locked with a hood-mounted striker. The hood release handle is located in the vehicle on the left side of the instrument panel beneath the ventilation duct. After the release handle has been pulled, the hood can be fully opened by hand. There is no additional latch on the hood.

After proper positioning of the hood bumpers, hood height is automatically controlled by the self-adjusting hood latch assembly. Proper hood alignment is essential for ease of latch operation.

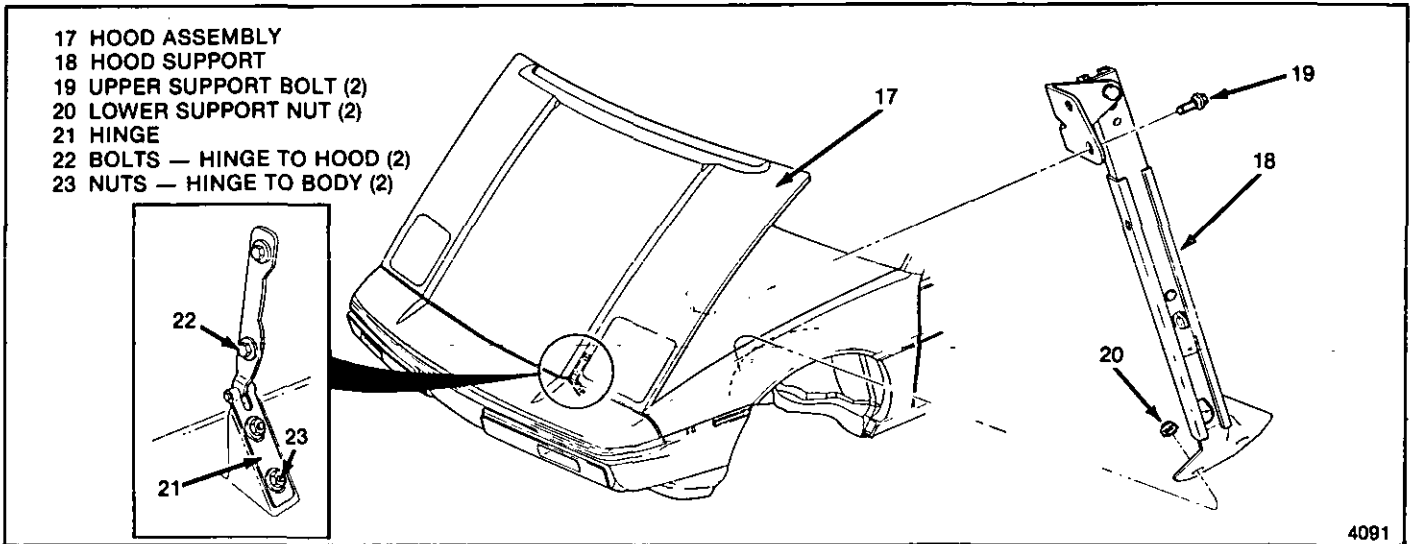

Fig. 3-Hood and Attaching Hardware

4091

**↔ Remove or Disconnect (Figure 4)**

1. Top shroud vent duct screen
2. Optional glass roof vent storage cover
3. Two bolts (25)
4. Latch (24)
5. Cable connector (29)

**→← Install or Connect (Figure 4)**

1. Cable connector (29)
2. Latch (24)
3. Bolts (25)

**! Important**

Tighten bolts finger tight, close hood to reposition latch assembly. Open hood and tighten bolts.

4. Optional glass roof vent storage cover
5. Top shroud vent duct screen

**Striker**

**↔ Remove or Disconnect (Figure 4)**

1. Nuts (28)
2. Striker (27)

**→← Install or Connect (Figure 4)**

1. Striker (27)
2. Nuts (28)

**Hood Ajar Switch**

A hood ajar switch is located in the front compartment area. This switch indicates if the hood is not fully closed by sending electrical current to an indicator light located in the instrument panel.

**↔ Remove or Disconnect**

**→← Install or Connect**

1. Electrical connector to switch
2. Switch to body

**Front Compartment Weatherstrip**

**↔ Remove or Disconnect (Fig. 5)**

1. Weatherstrip (1) by grasping weatherstrip and pulling from flange
2. Clean flange of excess sealer.

**→← Install or Connect**

1. Position butt joint (2) of weatherstrip to front center of flange in compartment opening.
2. Press down on weatherstrip (1) for entire length.

**GLASS ROOF VENT STORAGE COVER (OPTIONAL)**

**↔ Remove or Disconnect (Fig. 6)**

1. Screws (2)
2. Cover (1)

**→← Install or Connect**

1. Cover (1)
2. Screws (2)

**Tighten**

Screws 2.5 to 3 N·m (18-24 in-lb)

**FENDER PANEL**

The outer fender panel is attached to the inner fender panel and the front fascia by J-clips and bolts. Always use care when handling fenders to avoid marring the surfaces.

**↔ Remove or Disconnect (Figure 7)**

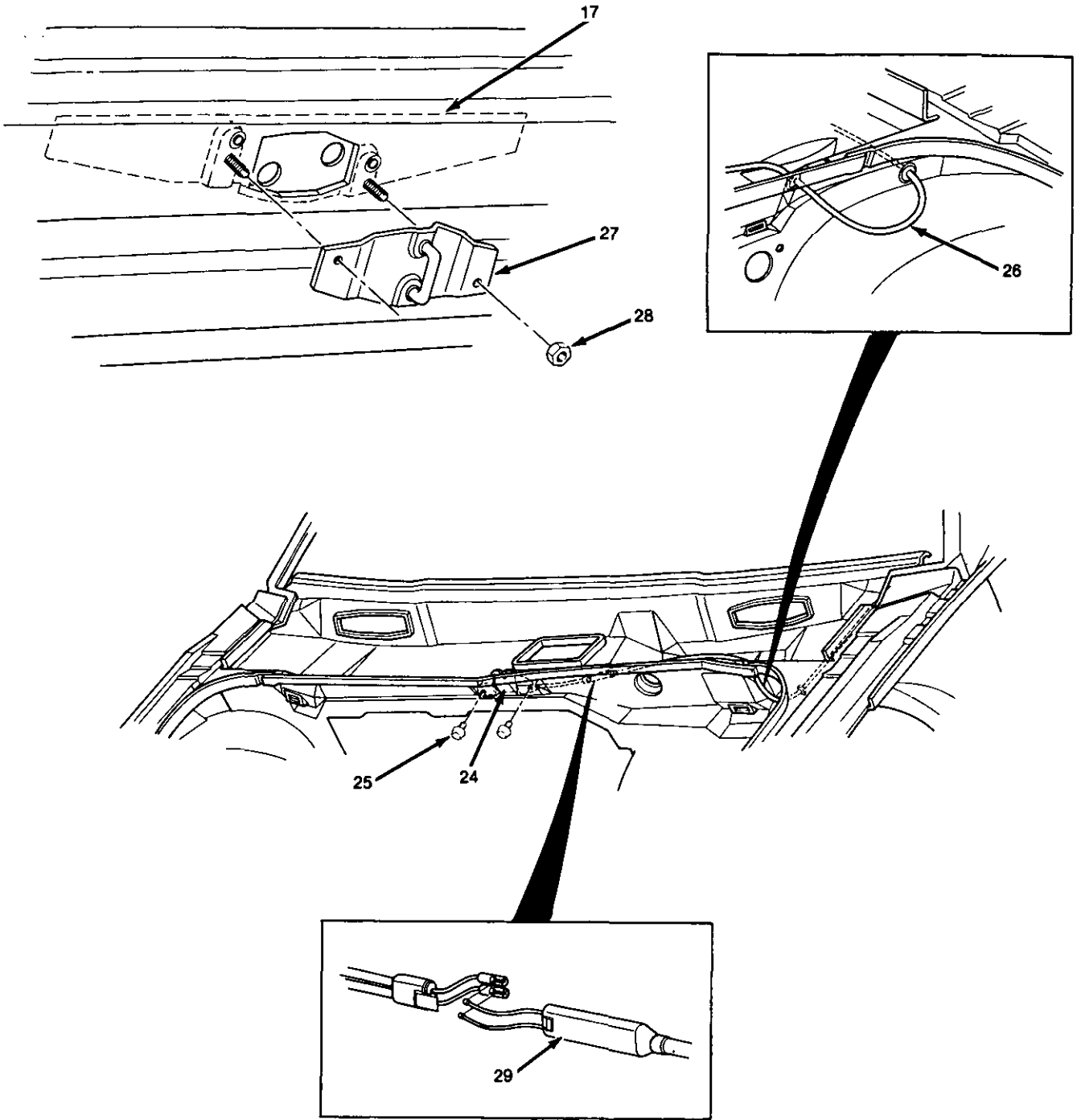

- |                        |                    |
|------------------------|--------------------|
| 24 HOOD LATCH          | 27 STRIKER         |
| 25 HOOD LATCH BOLT (2) | 28 STRIKER NUT (2) |
| 26 HOOD RELEASE CABLE  | 29 CABLE CONNECTOR |
| 17 HOOD                |                    |

Fig. 4-Hood Latch and Striker

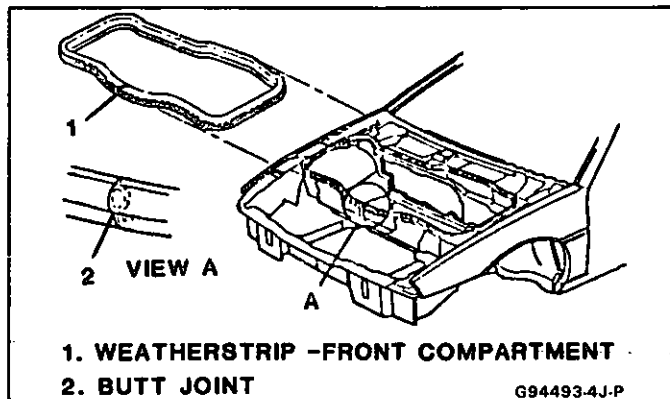

Fig. 5 - Installing Front Compartment Weatherstrip

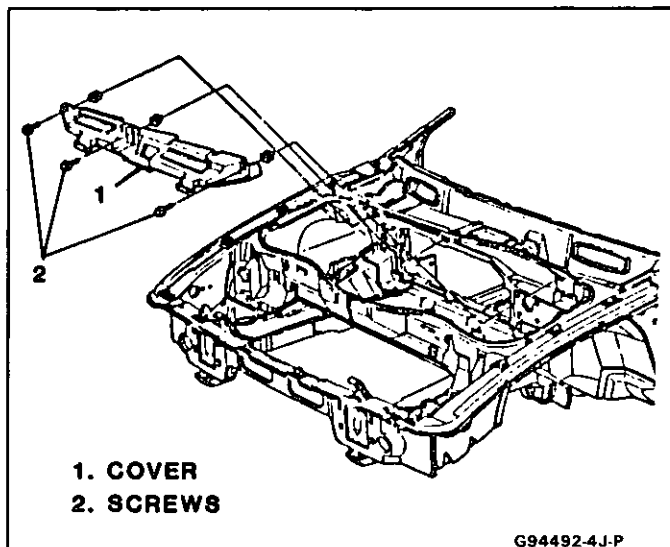

Fig. 6-Installing Optional Glass Roof Vent Storage Cover

3. Bolts and rivets
  - Top of fender to chassis (33)
  - Inner wheelwell panel to fender (36)
  - Upper forward front fender to fascia (32)
  - Rivet (37)
4. Fender panel (30)

**!** Important

Fender panel is held in place at rocker panel and the inner wheelwell panel with a tab. Remove carefully to avoid damage.

**↔** Install or Connect (Figure 7)

1. Fender panel (30)
  - Rocker panel tab through outer fender panel
  - Tuck fender panel under fascia and inner wheelwell tab
2. Bolts, attaching
  - Upper forward front fender to fascia (32)
  - Inner wheelwell panel to fender (36)
  - Top at fender to chassis (33)
  - Rivet front fender to fascia at marker light

**!** Inspect

For proper alignment of panel at hood, door, wheelhousing and fascia. The clearance between fender and door, and fender and front compartment hood should be 4 mm (5/32").

### FRONT WHEELHOUSE PANEL

**↔** Remove or Disconnect (Figure 8)

1. Attachments at
  - Fender panel (36)
  - Chassis (39)
  - Fascia (40)
2. Wheelhousing panel

**!** Important

Panel is retained to fender panel by a tab at center of wheel opening.

**↔** Install or Connect (Figure 8)

1. Wheelhousing tab to fender
2. Attachments at
  - Fascia (40)
  - Chassis (39)
  - Fender panel (36)

### GRILLE ASSEMBLY

**↔** Remove or Disconnect (Figure 9)

1. Bolts (42)
2. Grille (41)

**↔** Install or Connect (Figure 9)

1. Grille (41)
2. Bolts (42)

### FRONT FASCIA

**↔** Remove or Disconnect (Figure 10)

1. Six screws at chassis (44)
2. Side marker lamp assemblies (34, Fig. 7)
3. Bolts attaching
  - Fascia to fender at side marker lamp assembly (45A)
  - Inner wheelwell to fascia (40)
  - Fascia support (45)
4. Fascia (31)

**↔** Install or Connect (Figure 10)

1. Fascia (31)
2. Bolts attaching
  - Fascia support (45)
  - Inner wheelwell to fascia (40)
  - Fascia to fender at side marker lamp

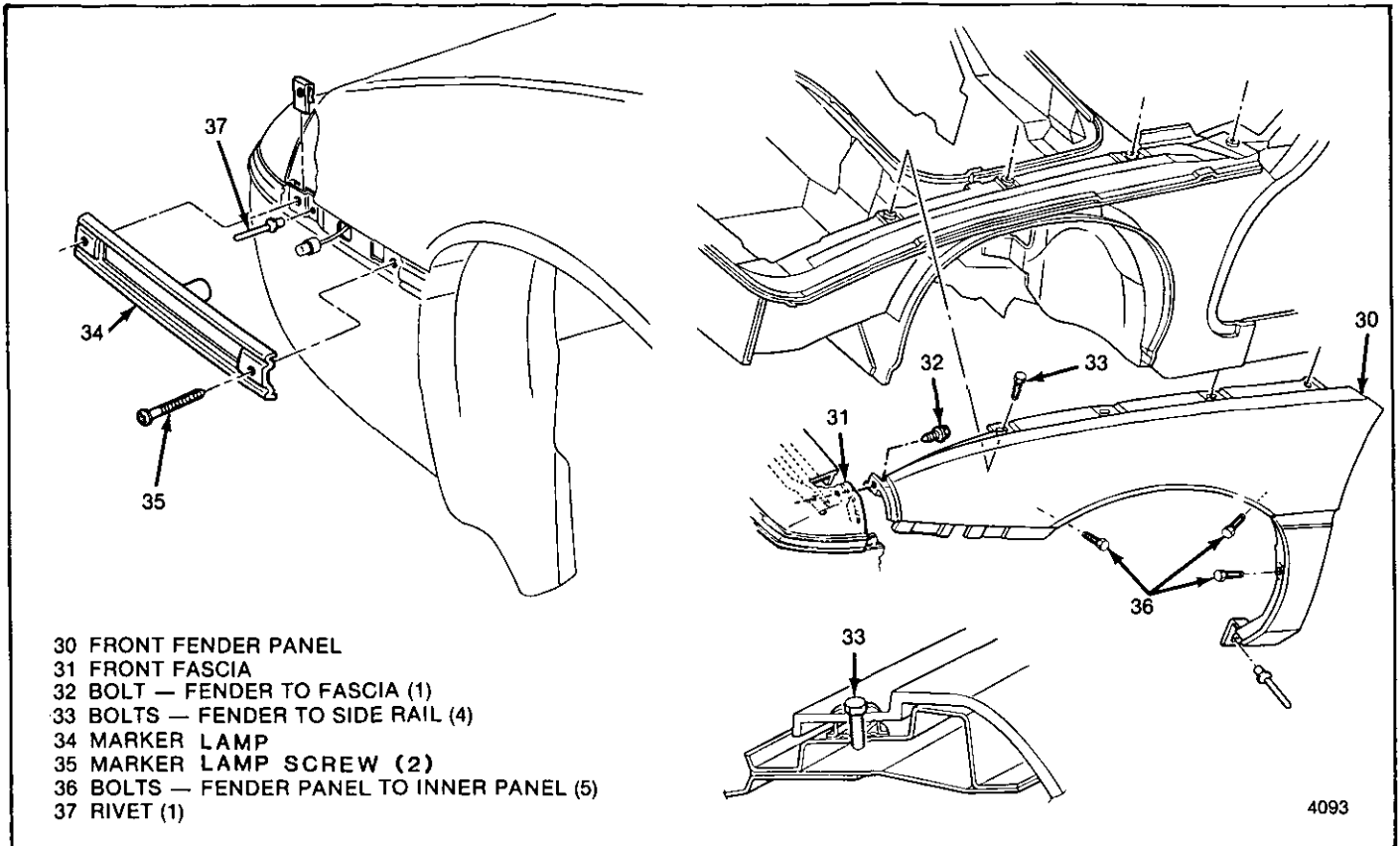

Fig. 7-Front Fender Panel Attachment

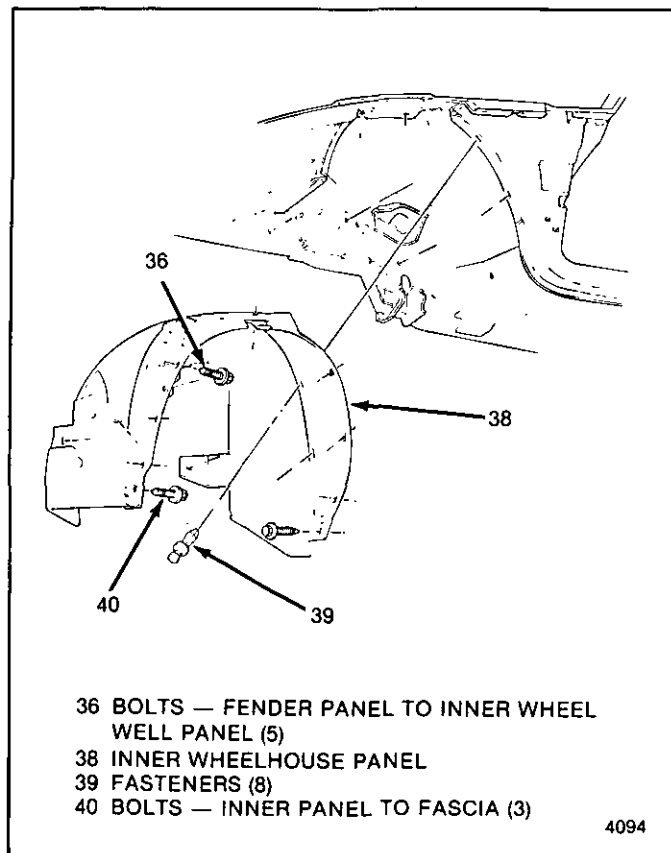

Fig. 8-Wheelhousing Panel Attachment

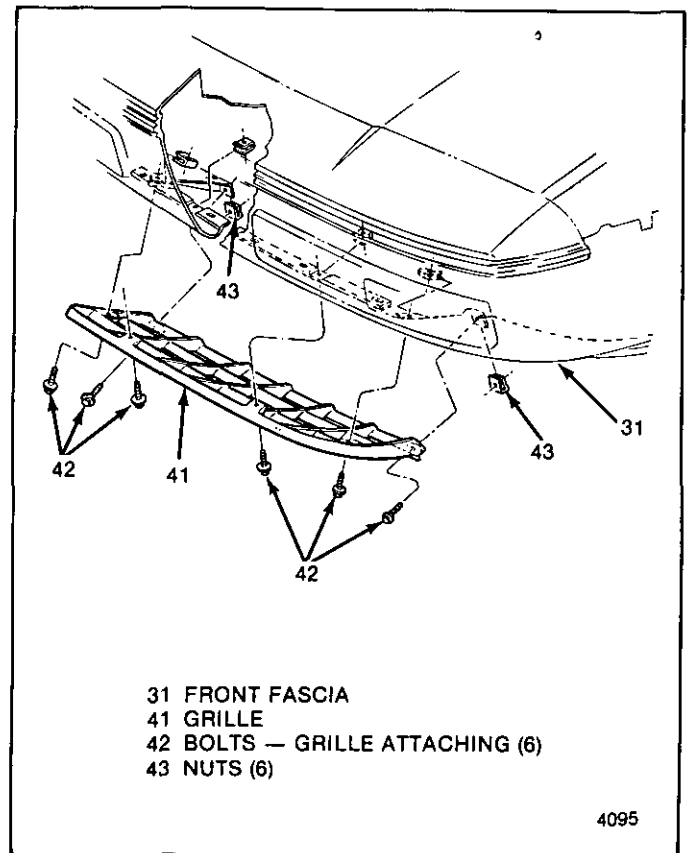

Fig. 9-Grille Assembly

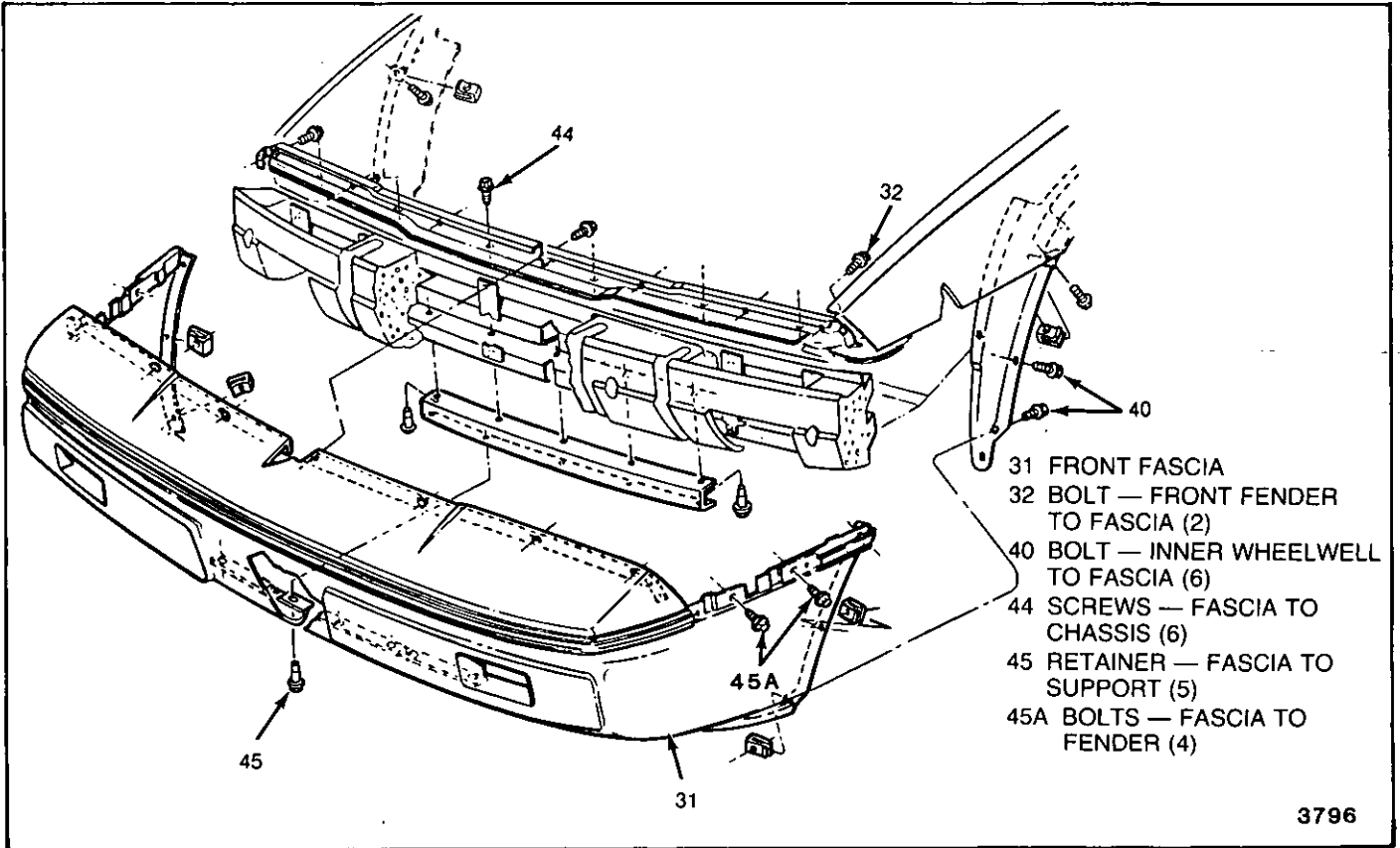

Fig. 10-Front Fascia Attachment

**Inspect**

For proper clearance between fascia and hood. Clearance should be no more than 4 mm (5/32").

**MOLDING**

The moldings on the fascia and the front fender where it attaches to the fascia are not removable. The rear portion of the front fender has a molding that is removable.

**Remove or Disconnect (Figure 11)**

1. Wheelhousing panel (rear half)
2. Two nuts (47)
3. Molding (46)

**Install or Connect (Figure 11)**

1. Molding (46)
2. Two nuts (47)
3. Wheelhousing panel (rear half)

**Inspect**

For proper alignment

**EXTENSION - ROCKER PANEL COVER TO FRONT FENDER**

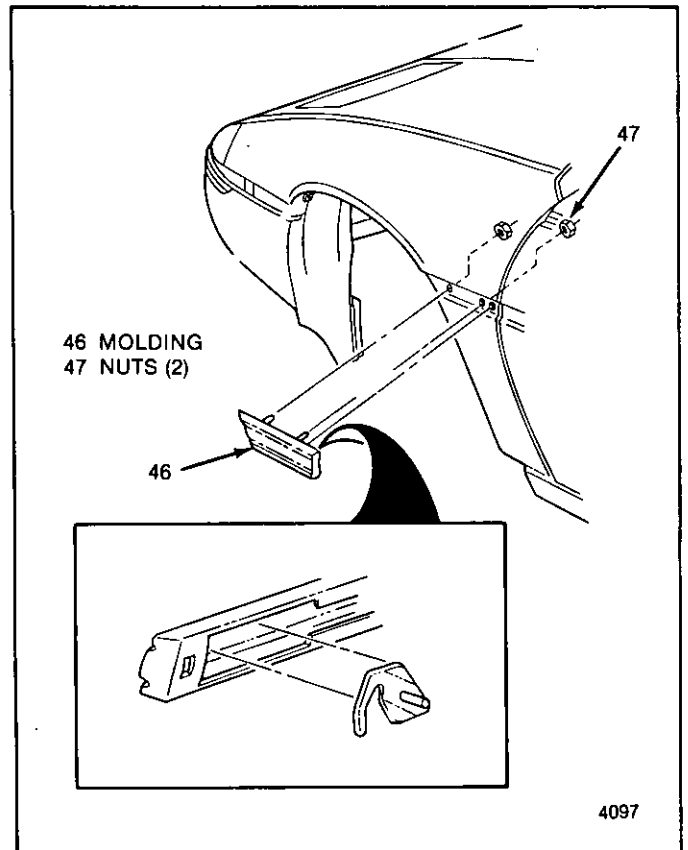

Fig. 11-Front Fender Molding

# SECTION 5

## DOORS

### CONTENTS

Doors .....	5-1	Door Lock Striker .....	5-9
Door Trim .....	5-1	Door Jamb Switch .....	5-11
Armrest and Pull Handle Assemblies .....	5-1	Outside Mirrors .....	5-11
Window Regulator Handle .....	5-1	Outside Mirror - Manual .....	5-11
Door Lock Knob and Remote		Mirror Glass - Manual .....	5-12
Handle Bezel .....	5-2	Remote Control Mirror - Manual .....	5-12
Door Trim Panel .....	5-2	Remote Control Mirror Glass -	
Door Map Pocket .....	5-4	Manual .....	5-12
Exterior Moldings .....	5-4	Remote Control Mirror Glass	
Center Molding Assembly .....	5-4	Assembly - Power .....	5-12
Rear Molding Assembly .....	5-4	Power Mirror Drive Unit .....	5-13
Door Assembly .....	5-4	Door Glass Assembly .....	5-14
Door Sealing .....	5-4	Door Glass Adjustment .....	5-14
Inner Door Window Belt Sealing		Window Regulator Cam Assembly .....	5-14
Strip .....	5-4	Regulator Assembly - Manual .....	5-15
Outer Door Window Belt Sealing		Regulator Assembly - Power .....	5-15
Strip .....	5-4	Rear Cam .....	5-17
Inner Panel Water Deflector .....	5-5	Front Glass Run Channel Assembly	
Door Opening Weatherstrips and		and Support Assembly .....	5-17
Channels .....	5-5	Cam Assembly - Front Door Inner	
Door Opening Weatherstrip .....	5-6	Panel .....	5-17
Weatherstrip Channels .....	5-7	Door Lock Assembly .....	5-18
Door Hardware Lubrication .....	5-7	Door Ajar Switch .....	5-18
Hardware Attachment Thread		Lock Cylinder Assembly .....	5-18
Locking .....	5-7	Power Door Lock Systems .....	5-18
Spring Clips .....	5-7	Power Lock Actuator .....	5-18
Connecting Rods and Locking Rods .....	5-7	Door Bell Crank .....	5-19
Inside Remote Handle .....	5-7	Door Hinge System .....	5-20
Outside Handle .....	5-7	Door Removal/Installation .....	5-20
Outer Door Panel Assembly .....	5-7	Door Hinge .....	5-20

## DOORS

This section of the manual contains the service operations necessary for the removal, installation, adjustment and sealing of door assemblies and the individual hardware and trim components. It is divided into three subsections:

- **Door Trim** – removal and installation procedures for all door trim items.
- **Exterior Moldings** – procedures for attaching exterior door moldings.
- **Door Assembly** – common items of door assemblies including door and side roof rail weatherstrip and all lock system components.

### DOOR TRIM

#### ARMREST AND PULL HANDLE ASSEMBLIES

##### Remove or Disconnect (Figure 5-1)

- Armrest plug (1)
- Screws (2)
- Armrest (3)

##### Install or Connect (Figure 5-1)

- Armrest (3)
- Screws (2)
- Armrest plug (1)

#### WINDOW REGULATOR HANDLE

##### Remove or Disconnect (Figures 5-2 and 5-3)

Tools Required:

J-9886 Door Handle Clip and Trim Pad Remover (or equivalent)  
J-24595B Door Trim Pad and Garnish Molding Clip Remover (or equivalent)

- Clip (12)
  - Depress trim panel
  - Insert J-9886 between handle and bearing plate (13). Tool should be in same plane as handle (Figure 5-2).
  - Push tool as indicated in Figure 5-3.
- Handle (11)
- Plate (13)

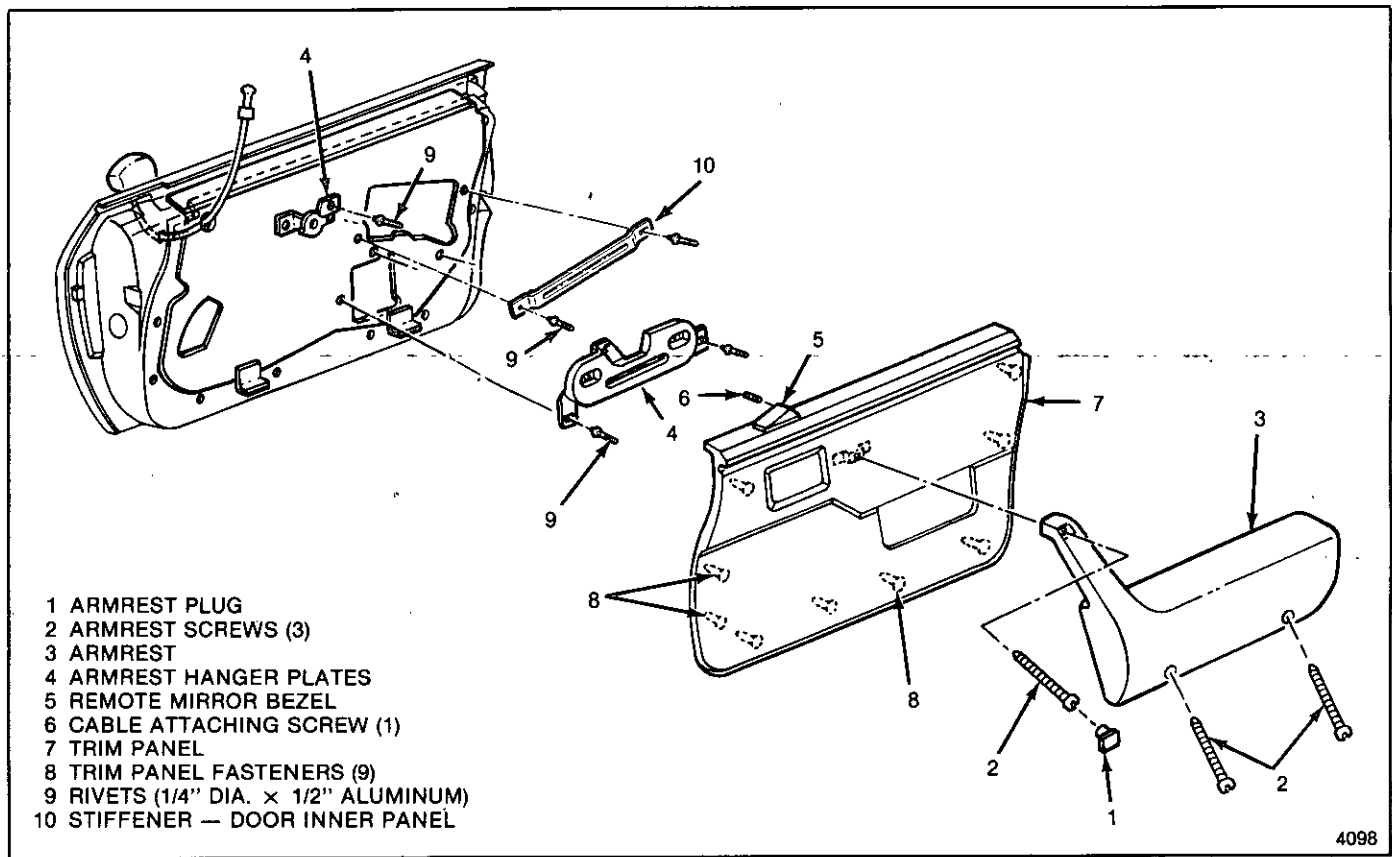

Fig. 5-1-Door Trim Panel and Armrest

↔ Install or Connect (Figures 5-2 and 5-3)

1. Plate (13)
2. Clip (12) on handle
3. Handle (11)
  - Position handle at same angle as opposite side handle
  - Press handle onto regulator spindle to engage clip

**DOOR LOCK KNOB AND REMOTE HANDLE BEZEL**

↔ Remove or Disconnect (Figure 5-4)

1. Covers (17)
2. Screws (16)
3. Lock knob (19)
  - Use a small flat-bladed tool such as a screwdriver.
  - Insert blade between end of knob and rod and pry to release knob.
  - Slide knob forward to remove.
4. Remote handle bezel (15)

↔ Install or Connect (Figure 5-4)

1. Remote handle bezel (15)
2. Lock knob (19)
  - o Insert lock rod through hole in bezel.
  - o Push end of knob on rod.

- Force knob against bezel until rod snaps into knob.

3. Screws (16)
4. Covers (17)

**DOOR TRIM PANEL**

↔ Remove or Disconnect (Figure 5-1)

Tools Required:

J-9886 Door Handle Clip and Trim Pad Remover (or equivalent)

J-24595B Door Trim Pad and Garnish Molding Clip Remover (or equivalent)

1. Armrest (3)
2. Window regulator handle (if equipped)
3. Remote handle bezel
4. Plastic retainers from perimeter of door (8).
  - Use J-9886 between panel and door.
5. Panel (7)
  - Pull outward to disengage from retainer at beltline.
6. Remote control mirror cable end (if equipped)
  - Screw (6)
  - Cable
7. Wire harness (if equipped)

🔍 Inspect



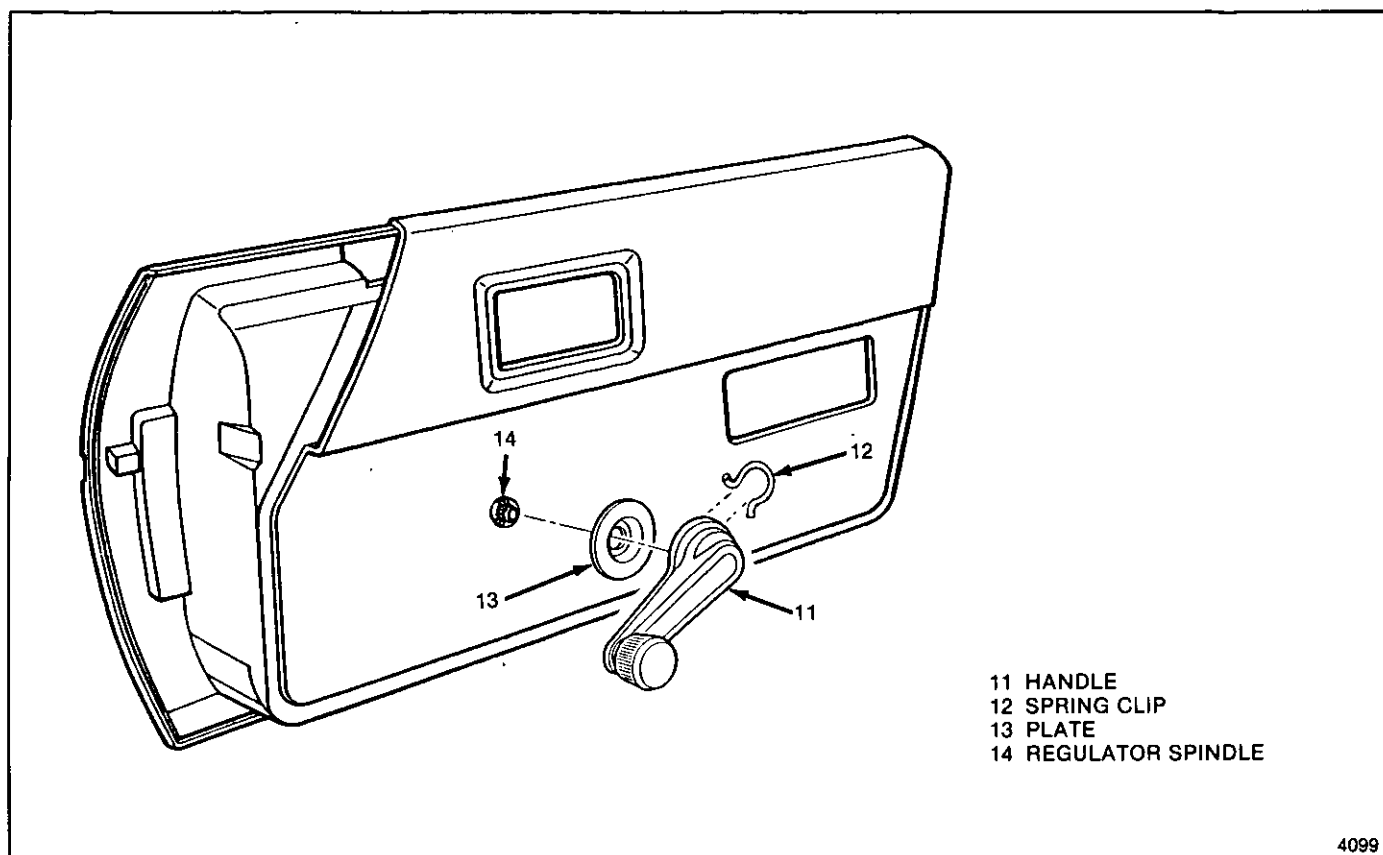

4099

Fig. 5-2-Window Regulator Handle

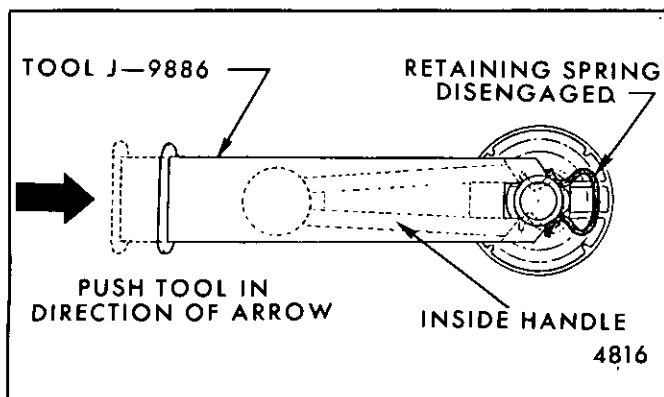

Fig. 5-3-Removing Window Regulator Handle

**↔ Install or Connect**

1. Insert flange in hole
2. Rotate retainer to engage flange

- Water deflector for proper installation

**↔ Install or Connect (Figure 5-1)**

1. Remote control mirror cable end (if equipped)
  - Cable
  - Screw (6)
2. Wire harness (if equipped)
3. Panel (7)
  - Insert top of panel in retainer
  - Insert remote handle through panel
  - Align retainers (8) with holes

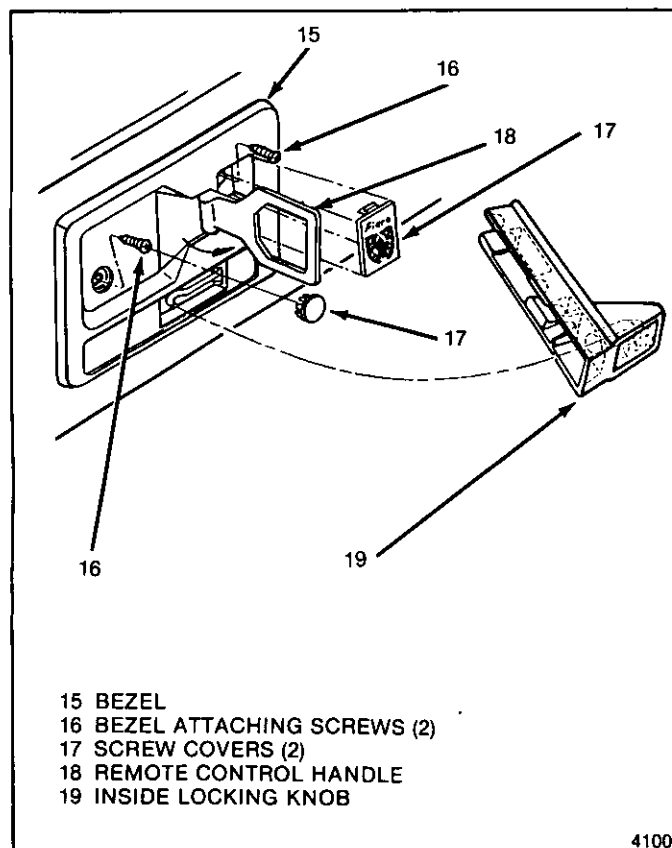

4100

Fig. 5-4-Remote Control Handle and Lock Knob

## 5.4 DOORS

- Tap into place with palm of hand or a clean rubber mallet.
- 4. Bezel
- 5. Lock knob
- 6. Window regulator handle (if equipped)
- 7. Armrest (3)

### Door Map Pocket

#### ←→ Remove or Disconnect

Tools Required:

J-23554 Inverted Nut Driver

1. Door trim panel
2. Six inverted nuts with J-23554

#### **CAUTION: Wear eye protection to prevent injury when cutting studs**

To allow access for J-23554, cut approximately 6 mm (1/4") from map pocket studs with suitable tool.

3. Door map pocket

#### ! Important

If the left side door map pocket is being replaced, be sure to transfer the spring clip at the rear inner seam to the new map pocket to prevent interference with the emergency brake handle.

#### →← Install or Connect

1. Door map pocket
2. Six inverted nuts with J-23554
3. Door trim panel

## EXTERIOR MOLDINGS

### CENTER MOLDING ASSEMBLY

#### ←→ Remove or Disconnect (Figure 5-5)

1. Door trim panel
2. Water deflector
3. Nut (24) from rear clip (25)
  - Put window in full-up position to allow access to nut from inside of door panel.
4. Plastic retainer, (23) at outside door handle
5. Molding assembly (22)

#### →← Install or Connect (Figure 5-5)

1. Molding assembly (22)
2. Plastic retainer (23)
3. Nut (24)
4. Water deflector
5. Door panel

### REAR MOLDING ASSEMBLY

#### ←→ Remove or Disconnect (Figure 5-5)

1. Door trim panel

4. Loosen rear section of outer door panel from top to gain access to retaining screw
5. Screw (21)
6. Molding (20)

#### →← Install or Connect (Figure 5-5)

1. Molding (20)
2. Screw (21)
3. Rear section of outer door panel
4. Nut (24) to rear clip (25)
5. Outside door handle
6. Door trim panel

### EXTENSION - ROCKER COVER PANEL TO DOOR

See procedure in Section 6 in the body portion of this manual.

## DOOR ASSEMBLY

### DOOR SEALING

The following section contains service operations necessary to remove and replace the components which seal the door against air and water entry into the passenger compartment.

#### Inner Door Window Belt Sealing Strip

#### ←→ Remove or Disconnect (Figure 5-6)

1. Door trim panel
2. Retainer (31)
3. Sealing strip (30)

#### →← Install or Connect (Figure 5-6)

1. Sealing strip (30)
2. Retainer (31)
3. Door trim panel

#### Outer Door Window Belt Sealing Strip

#### ←→ Remove or Disconnect (Figure 5-6)

1. Door trim panel
2. Water deflector (34)
3. Front filler sealing strip (32)
4. Mirror
5. Door glass
6. Screws - sealing strip attaching
7. Sealing strip (29)

#### →← Install or Connect (Figure 5-6)

1. Sealing strip (29)
2. Screws
3. Door glass
4. Mirror
5. Front filler sealing strip (32)

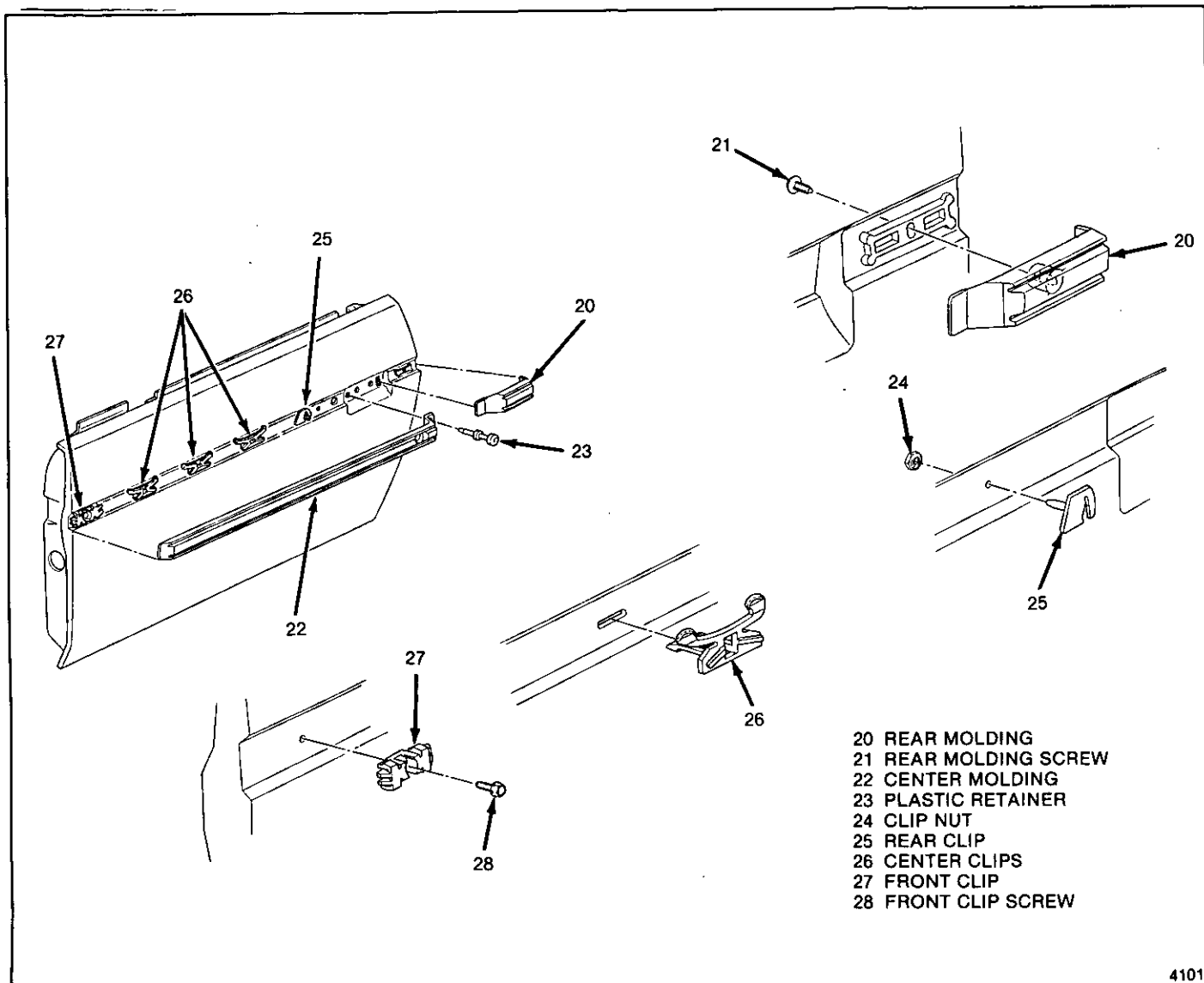

Fig. 5-5-Exterior Door Moldings

4101

### Inner Panel Water Deflector

The water deflector is secured by a string loaded sealing material and by sealing tape. When removal of deflector is required, it must be properly sealed for replacement. If additional sealing material is required, strip caulking is recommended.

For access to inner panel, the deflector may be either partially or completely detached as required.

#### ↔ Remove or Disconnect (Figures 5-1, 5-7 and 5-8)

1. Door trim panel
2. Armrest hanger plates (4)
3. Stiffener (10)
4. Water deflector (34)

- Use a flat-bladed tool such as a putty knife to release sealer. Keep blade between inner panel and the string that is embedded in the sealer.

#### 👁 Inspect

For holes or tears in deflector. Apply waterproof tape to both sides if necessary. Replace deflector if it cannot be properly repaired.

#### ↔ Install or Connect (Figures 5-1, 5-7 and 5-8)

1. Water deflector (34). Apply additional strip caulk and tape as required.
2. Stiffener (10)
3. Armrest hanger plates (4)
4. Door trim panel

### DOOR OPENING WEATHERSTRIPS AND CHANNELS

The door opening weatherstrips are a bulbar type. They are installed on the body pinchweld flange around door opening and are friction retained on pinchweld around door opening and adhesive retained in the channels around the window glass opening. There are four screws at beltline.

## 5-6 DOORS

- 29 OUTER BELT SEALING STRIP
- 30 INNER BELT SEALING STRIP
- 31 RETAINER FRONT DOOR TRIM AT BELT
- 32 FRONT FILLER SEALING STRIP
- 33 REAR FILLER SEALING STRIP
- 34 WATER DEFLECTOR

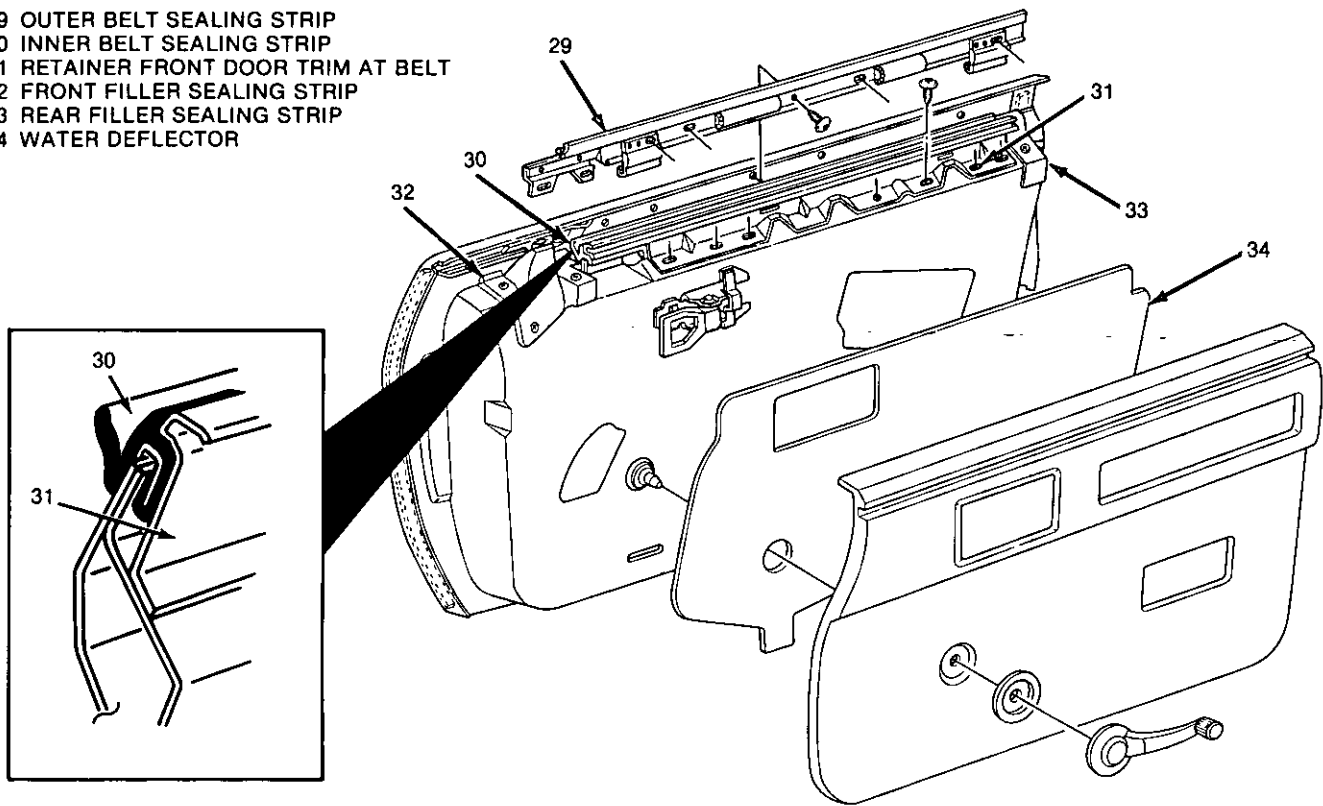

4102

Fig. 5-6-Door Sealing Components

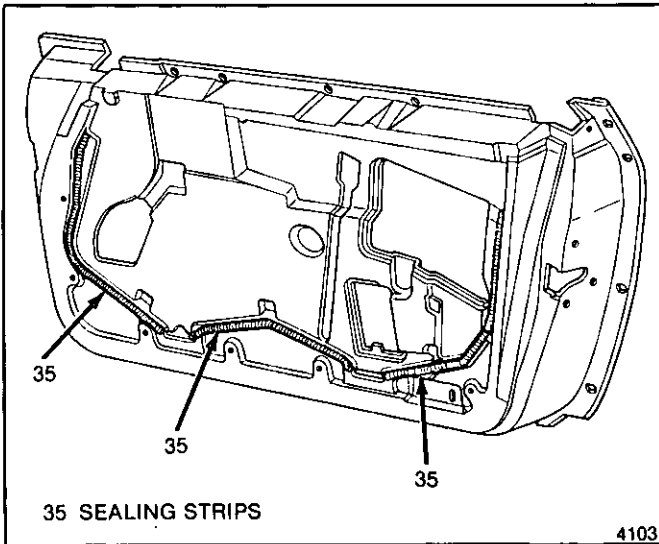

4103

Fig. 5-7-Door Inner Panel Water Deflector Sealing Locations

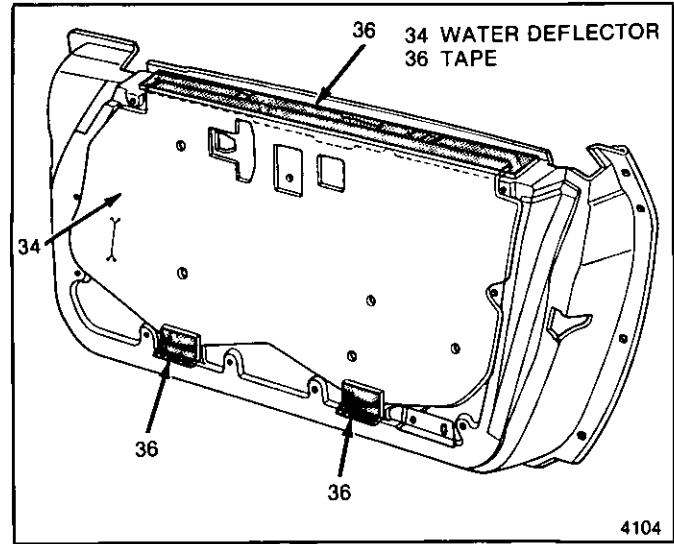

4104

Fig. 5-8-Door Inner Panel Water Deflector Tape Locations

### Door Opening Weatherstrip

#### ↔ Remove or Disconnect (Figure 5-9)

1. Lower garnish molding. Refer to Section 3.
2. Loosen quarter trim panel
3. Screws (39)
4. Door opening weatherstrip (38)

#### →← Install or Connect (Figure 5-9)

1. Door opening weatherstrip (38)
  - Apply a medium bodied sealer in cavity of weatherstrip

- Start at any convenient location, grasp the weatherstrip and pull from the pinchweld flange and channel; continue around entire door opening.

- Be certain to obtain full engagement on the pinchweld flange and in the channels.
2. Screws (39)
  3. Tighten quarter trim panel
  4. Lower garnish molding

### Weatherstrip Channels

#### Remove or Disconnect (Figure 5-9)

1. Weatherstrip (38)
2. Screws
3. Channels (37)



#### Inspect

Channel seal and repair or replace if damaged.

#### Install or Connect (Figure 5-9)

1. Channels (37)
2. Screws
3. Weatherstrip (38)

### DOOR HARDWARE LUBRICATION

The mechanical components of the door assembly are lubricated during assembly. If additional lubrication is required, use the following lubricants. Door lock cylinders should be lubricated with a light oil. Door hinge pins and rollers should be lubricated at normal service intervals with 30 weight engine oil. Do not lubricate hinge roller to hold-open link contacting surfaces as this may prevent the roller from rolling properly. The remainder of all door hardware mechanisms except lock assemblies can be lubricated with part no. 1052349, Lubricate Spray-Lube A, part no. 1052196, Lubriplate Auto-Lube A or equivalent.

### HARDWARE ATTACHMENT THREAD LOCKING

Door hardware production attaching screws contain an epoxy thread-locking compound to insure that the minimum original torque setting will be maintained.

Service attaching screws may not contain a thread-locking compound. To prevent loosening of service screws or to renew thread-locking characteristics of production screws, the threads of the fastener(s) can be treated with part no. 1052279, Loctite 75 or equivalent, which is a two-part material applied to the hardware attachment as a liquid. Upon installation and tightening, the adhesive cures to bond the attachment and prevent loosening or back out. The adhesive bond does not prevent future removal if required. Loctite 75 or equivalent can be used on any threaded fastener.

### SPRING CLIPS

Spring clips are used to secure remote control connecting rods and inside locking rods to levers and handles. A slot in the clip provides for disengagement of the clips which allows for easier detachment of linkage.

#### Remove or Disconnect (Figure 5-10)

1. Tang from lever. Use an awl or thin-bladed screwdriver.
2. Clip from rod. Slide clip on lever to disengage from rod.

#### Install or Connect (Figure 5-10)

1. Rod in lever
2. Clip to rod. Slide clip on lever to engage tang.

### CONNECTING RODS AND LOCKING RODS

#### Remove or Disconnect (Figure 5-11)

1. Door trim panel
2. Water deflector
3. Connecting rods and/or locking rods as required.

#### Install or Connect (Figure 5-11)

1. Connecting rods and/or locking rods.



#### Inspect

- For proper operation.
2. Water deflector
  3. Door trim panel

### INSIDE REMOTE HANDLE

#### Remove or Disconnect (Figure 5-12)

1. Door trim panel
2. Connecting rod clip (46)
3. Rivet at remote handle (44)
4. Remote handle (18)

#### Install or Connect (Figure 5-12)

1. Remote handle (18)
2. Rivet (44)
3. Connecting rod (47)
4. Door trim panel

### OUTSIDE HANDLE

#### Remove or Disconnect (Figures 5-13 and 5-14)

1. Door trim panel
2. Two nuts at door handle (49)
3. Retainer and outside locking rod (50)
4. Handle assembly (48)

#### Install or Connect (Figures 5-13 and 5-14)

1. Handle assembly (48)
2. Two nuts (49)
3. Outside handle locking rod (50) and retainer
4. Door trim panel

### OUTER DOOR PANEL ASSEMBLY

#### Remove or Disconnect (Figures 5-5, 5-6, and 5-14)

1. Door trim panel

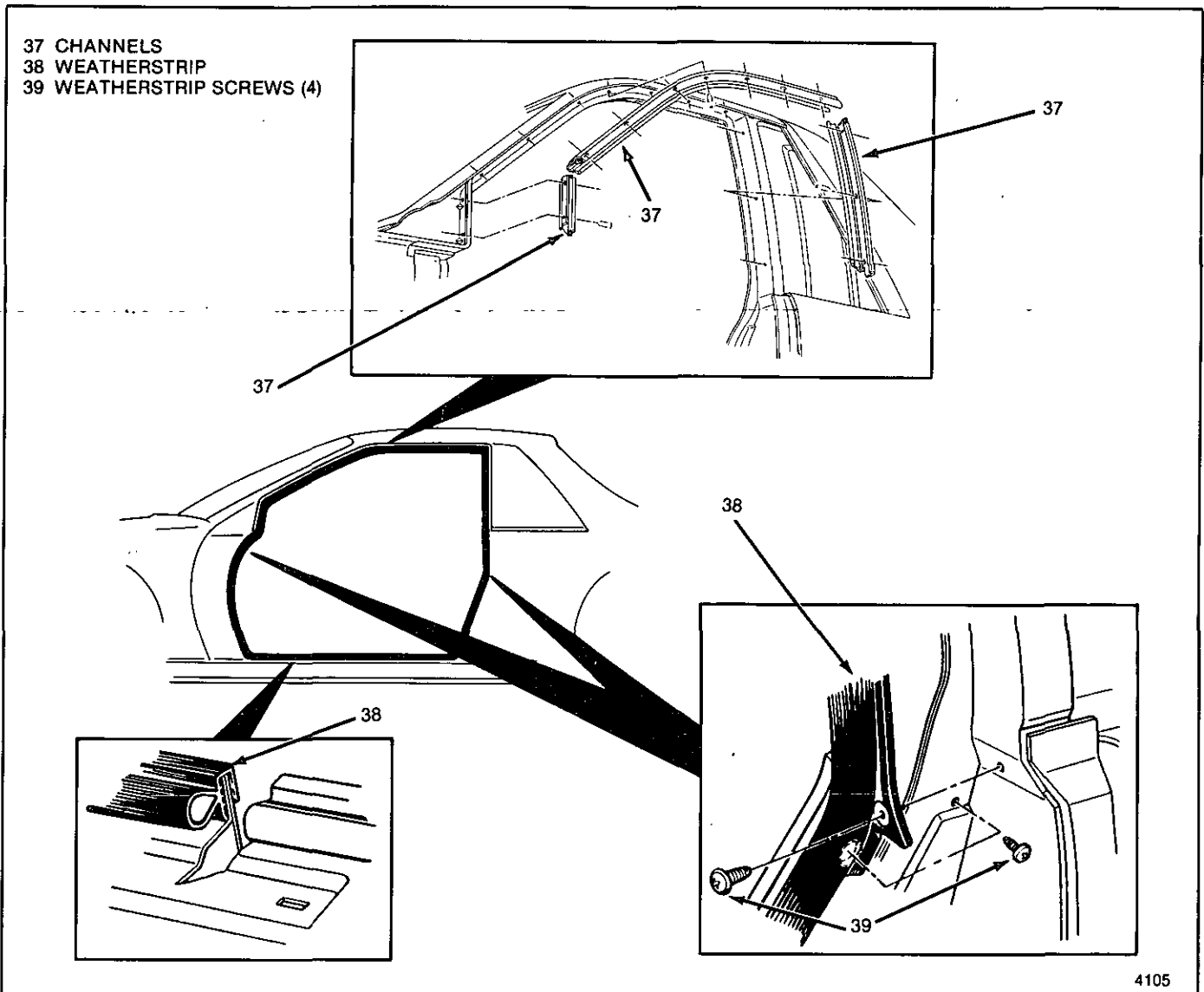

Fig. 5-9-Door Opening Weatherstrips and Channels

4105

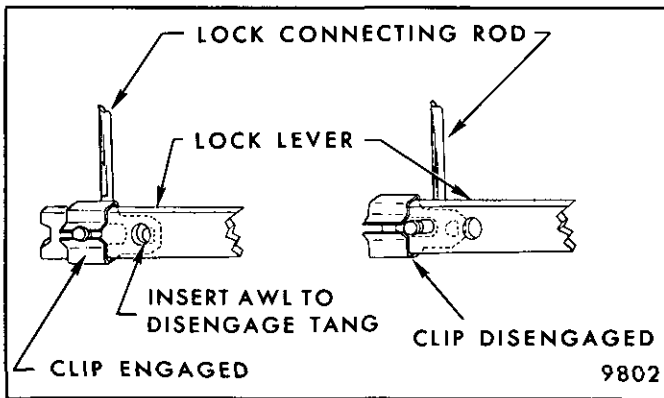

Fig. 5-10-Removing Spring Clip

6. Center molding assembly (22)
7. Two 7 mm bolts (28)
8. Front filler sealing strip (32)
9. Mirror
10. Four peel type rivets (60)
11. Outer door panel (56). Pull panel away from inner door to disengage retainers at top. Pull panel straight back as if it were hinged at the back of the inner door.
12. All attaching rods

**Install or Connect (Figures 5-5, 5-6, and 5-14)**

1. All rods to outer door panel
2. Outer door panel (56)
3. Nine screws (59) from front and rear of inner panel
4. Two 7 mm bolt (28)

**Inspect**

2. Water deflector (34)
3. Nine screws (59) from front and rear of inner panel assembly
4. Nut from rear clip (24). Put window in full-up position to allow access to nut from inside of door

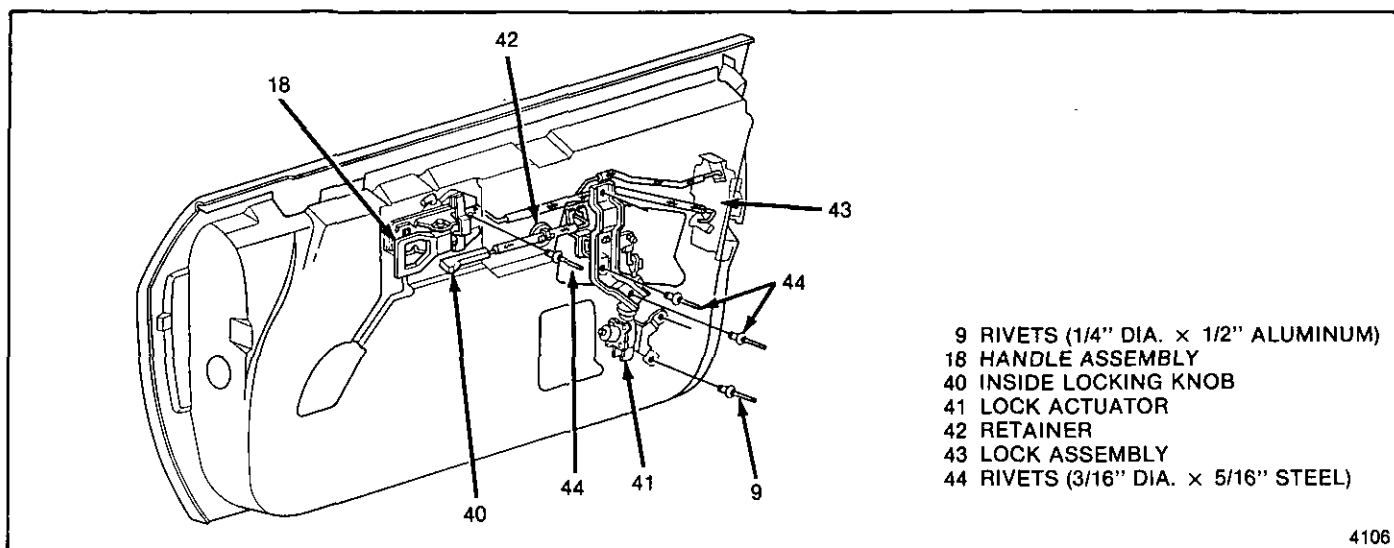

4106

Fig. 5-11-Connecting Rods and Locking Rods

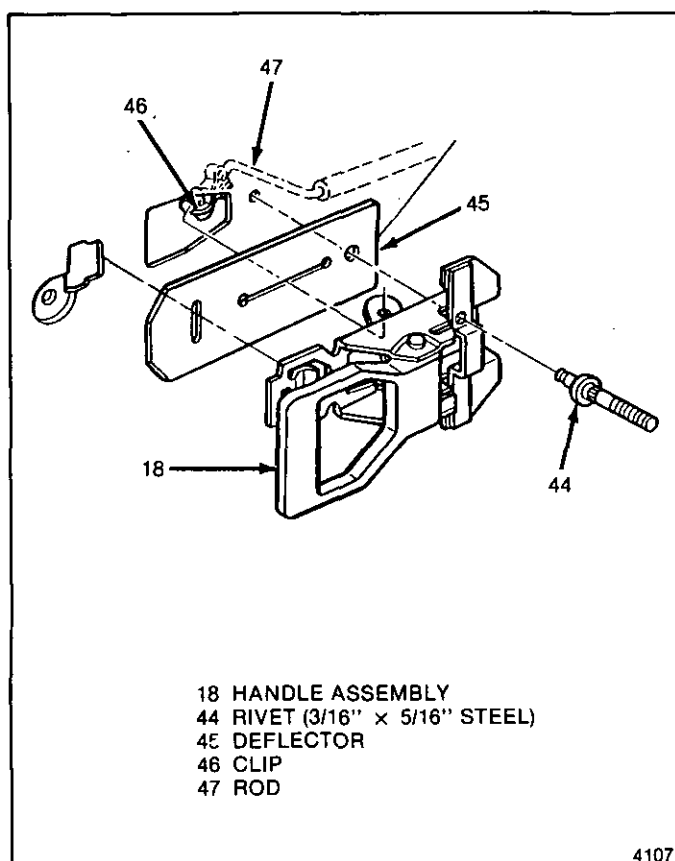

4107

Fig. 5-12-Inside Remote Handle

6. Center molding assembly (22)
7. Outside door handle
8. Nut on rear clip (24)
9. Mirror
10. Front filler sealing strip (32)
11. Water deflector (34)
12. Door trim panel

## DOOR LOCK STRIKER

The door lock striker consists of a single metal bolt and washer assembly which is threaded into a tapped, floating cage plate in the body pillar. The door

is secured in the closed position when the door lock fork bolt snaps over and engages the striker bolt.

**NOTICE:** The door lock striker is an important attaching part in that it could affect the performance of vital components and systems, and/or could result in major repair expense. It must be replaced with one of the same part number or with an equivalent part if replacement becomes necessary. Do not use a replacement part of lesser quality or substitute design. Torque values must be used as specified during reassembly to assure proper retention of this part.



### Inspect (Figures 5-15, 5-17)

- Fore and aft adjustment
  - Check for proper door alignment.
  - Apply modeling clay or body caulking to lock bolt opening.
  - Close door only as far as necessary for striker to form an impression in clay or compound. Complete closing will make clay removal difficult.
  - Striker should be centered fore and aft.



### Important

Minimum and maximum dimensions must be strictly maintained.

- Minimum allowable dimension 2 mm (3/32")
- Maximum allowable dimension 4 mm (5/32")



### Adjust

Tools Required:

J-23457 Door lock striker wrench (or equivalent)

- Remove striker with J-23457.
- Install spacer or spacers as required to obtain correct alignment. The following spacers are available as service parts:

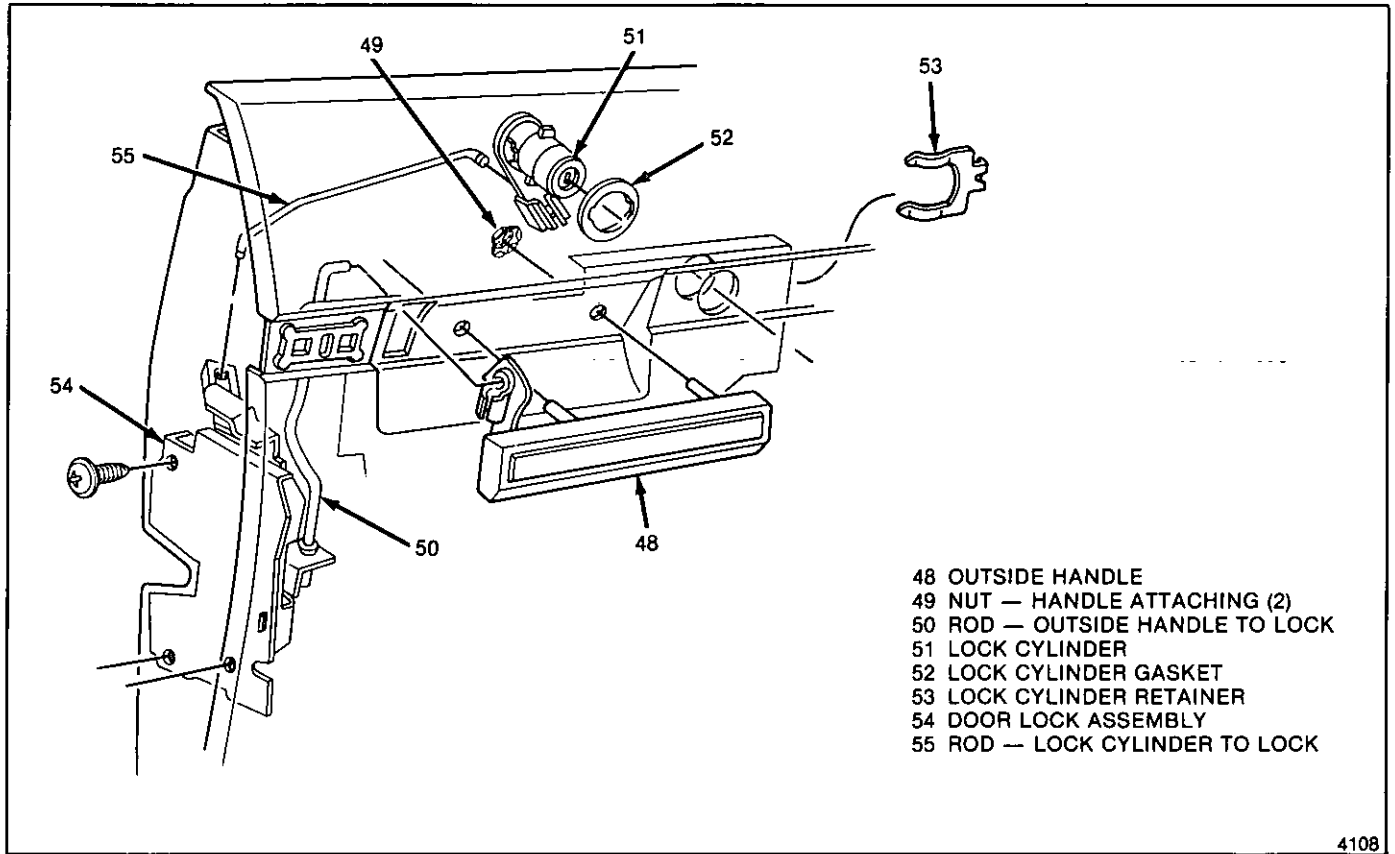

4108

Fig. 5-13-Door Locking Mechanism

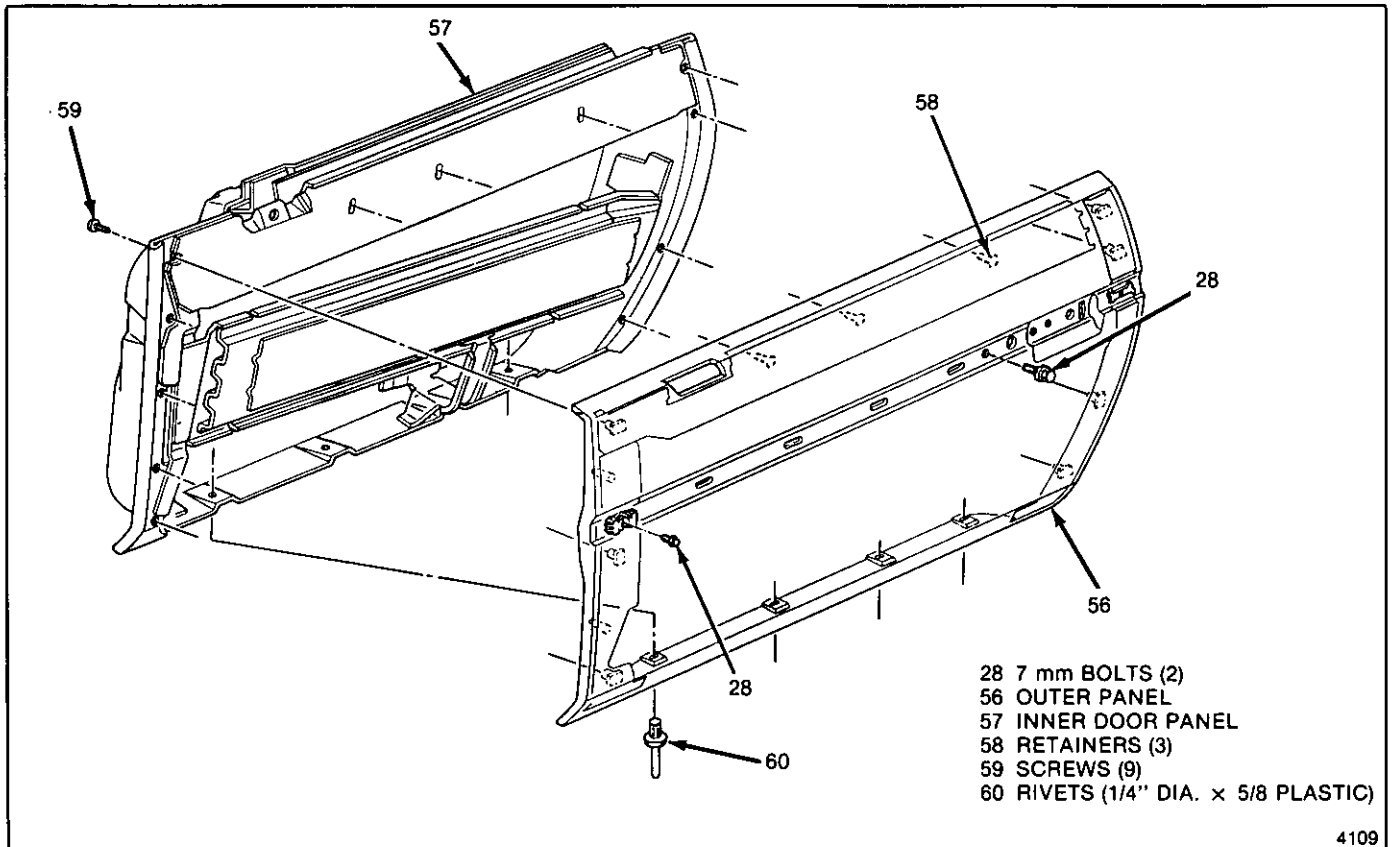

4109

Fig. 5-14-Outer Door Panel



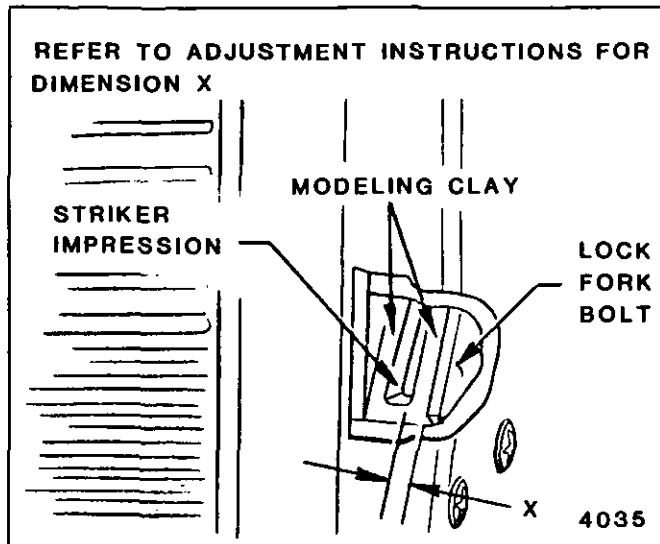

Fig. 5-15-Lock-to-Striker Engagement

- 2 mm (3/32") part no. 4469196
- 4 mm (5/32") part no. 4469197

- Replace striker



Tighten

Striker from 40 to 60 N·m (34 to 46 ft-lb).



Inspect

Up or down, in or out adjustment



Adjust (Figures 5-16, 5-17)

Tools Required:

J-23457 Door lock striker wrench (or equivalent)  
 3/8" rotary file with a flat end

- Remove striker with J-23457.
- Enlarge hole in the direction required.

**NOTICE:** It is important that a flat end rotary file be used so that no damage is done to the tapped cage plate. The striker bolt and cage plate are important attaching parts that could affect the performance of vital components and systems.

- Install striker



Tighten

Striker from 40 to 60 N·m (34 to 46 ft-lb)

## DOOR JAMB SWITCHES

Door jamb switch assemblies consist of a plunger, plunger collar, threaded retainer and terminals. They are installed in the front door hinge pillars. When the door of the vehicle is closed, the plunger is depressed which creates an open in the ground circuit. When the door is opened, the plunger is released and completes the circuit to ground (Fig. 5-18).

When a new jamb switch is installed and the door is closed the first time, the plunger is forced into the sleeve and automatically adjusts the jamb switch for that particular door. If a jamb switch fails, it should not

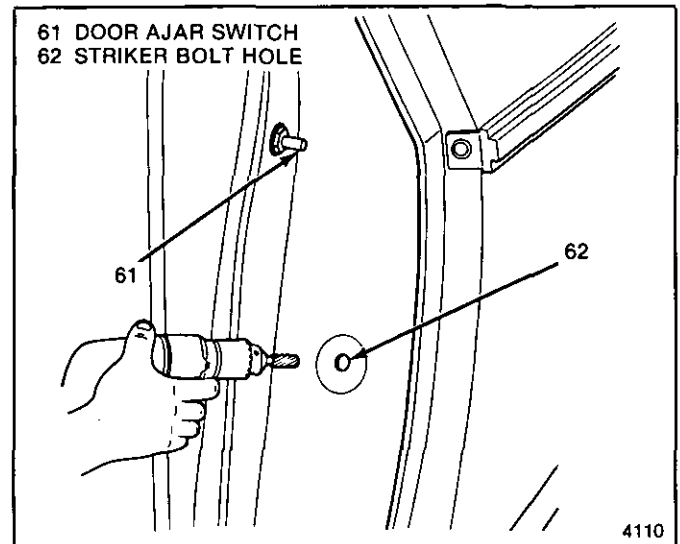

Fig. 5-16-Striker Bolt Hole Enlargement

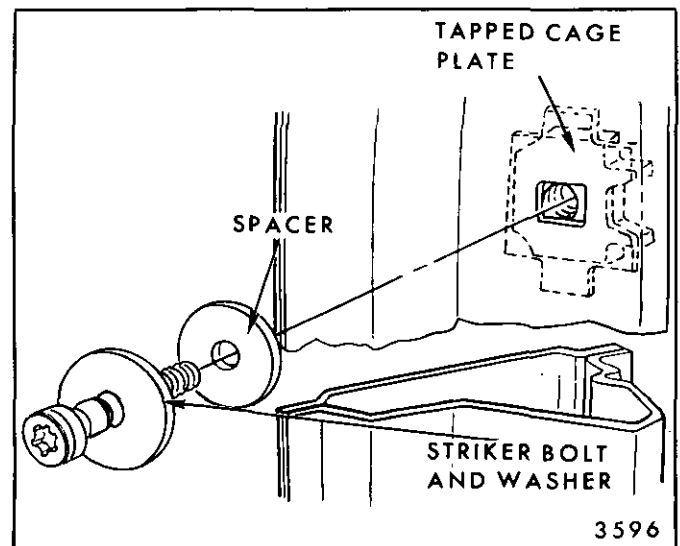

Fig. 5-17-Typical Door Lock Striker Mechanism

be readjusted by hand. A new jamb switch should be installed.



Remove or Disconnect

1. Jamb switch
2. Electrical connector



Install or Connect

1. Electrical connector
2. Jamb switch

## OUTSIDE MIRROR

### Outside Mirror - Manual



Remove or Disconnect (Figure 5-19)

1. Door trim panel
2. Front filler weatherstrip
3. Mirror attaching nuts (67)
4. Mirror (64)

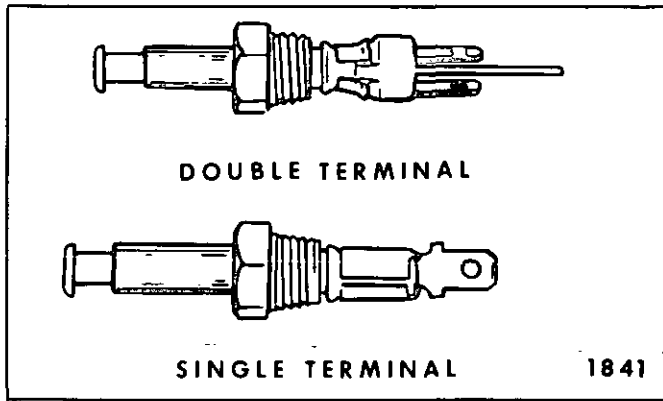

Fig. 5-18-Door Jamb Switches

**→← Install or Connect (Figure 5-19)**

1. Mirror (64)
2. Mirror attaching nuts (67)
3. Front filler weatherstrip
4. Door trim panel

**Mirror Glass - Manual**

**↔ Remove or Disconnect (Figure 5-19)**

1. Upper screw
  - Put mirror glass (63) in full-down position for access
2. Lower screws
  - Put mirror glass (63) in full-up position for access
3. Mirror glass assembly (63)

**→← Install or Connect (Figure 5-19)**

1. Mirror glass assembly (63)
2. Lower screws
  - Put mirror glass (63) in full-up position for access
3. Upper screws
  - Put mirror glass (63) in full-down position for access

**Remote Control Mirror - Manual**

**↔ Remove or Disconnect (Figure 5-20)**

1. Door trim panel
2. Remote control cable end
3. Front filler weatherstrip
4. Mirror attaching nuts (67)
5. Mirror (68)

**→← Install or Connect (Figure 5-20)**

1. Feed cable through door opening
2. Mirror (68)
3. Mirror attaching nuts (67)

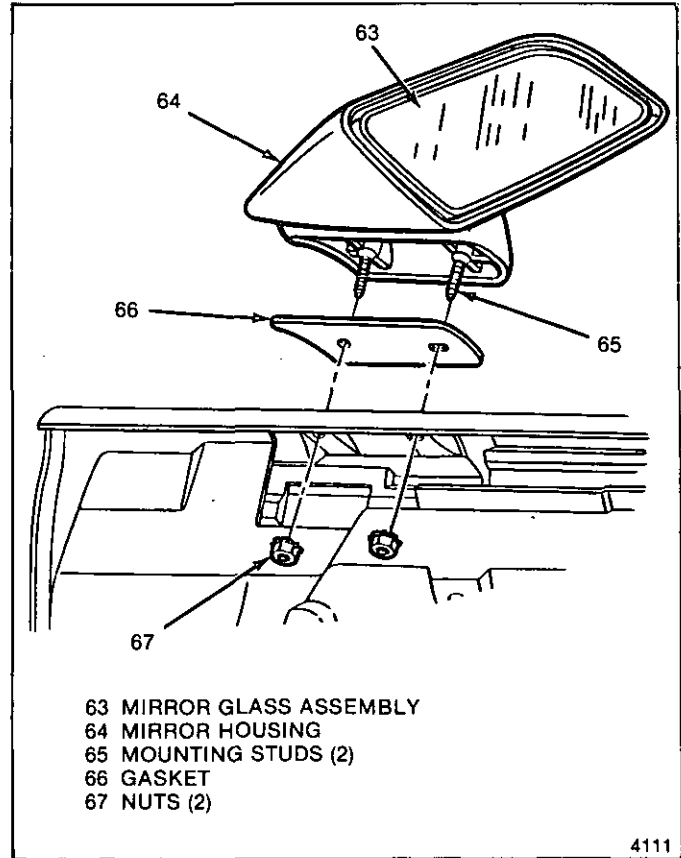

Fig. 5-19-Outside Mirror - Manual

**Remote Control Mirror Glass - Manual**

**↔ Remove or Disconnect (Figure 5-20)**

1. Mirror (68)
2. Upper screws
  - Put mirror glass (69) in full-down position for access
3. Lower screws
  - Put mirror glass (69) in full-up position for access
4. Mirror glass assembly (69)

**→← Install or Connect**

1. Mirror glass assembly (69)
2. Lower screws
  - Put mirror glass (69) in full-up position for access
3. Upper screws
  - Put mirror glass (69) in full-down position for access
4. Mirror (68)

**Remote Control Mirror Glass Assembly - Power**

The glass assembly may be removed without removing the mirror from the vehicle.

**↔ Remove or Disconnect (Figure 5-21)**

1. Glass inboard and outboard edges of glass (71)

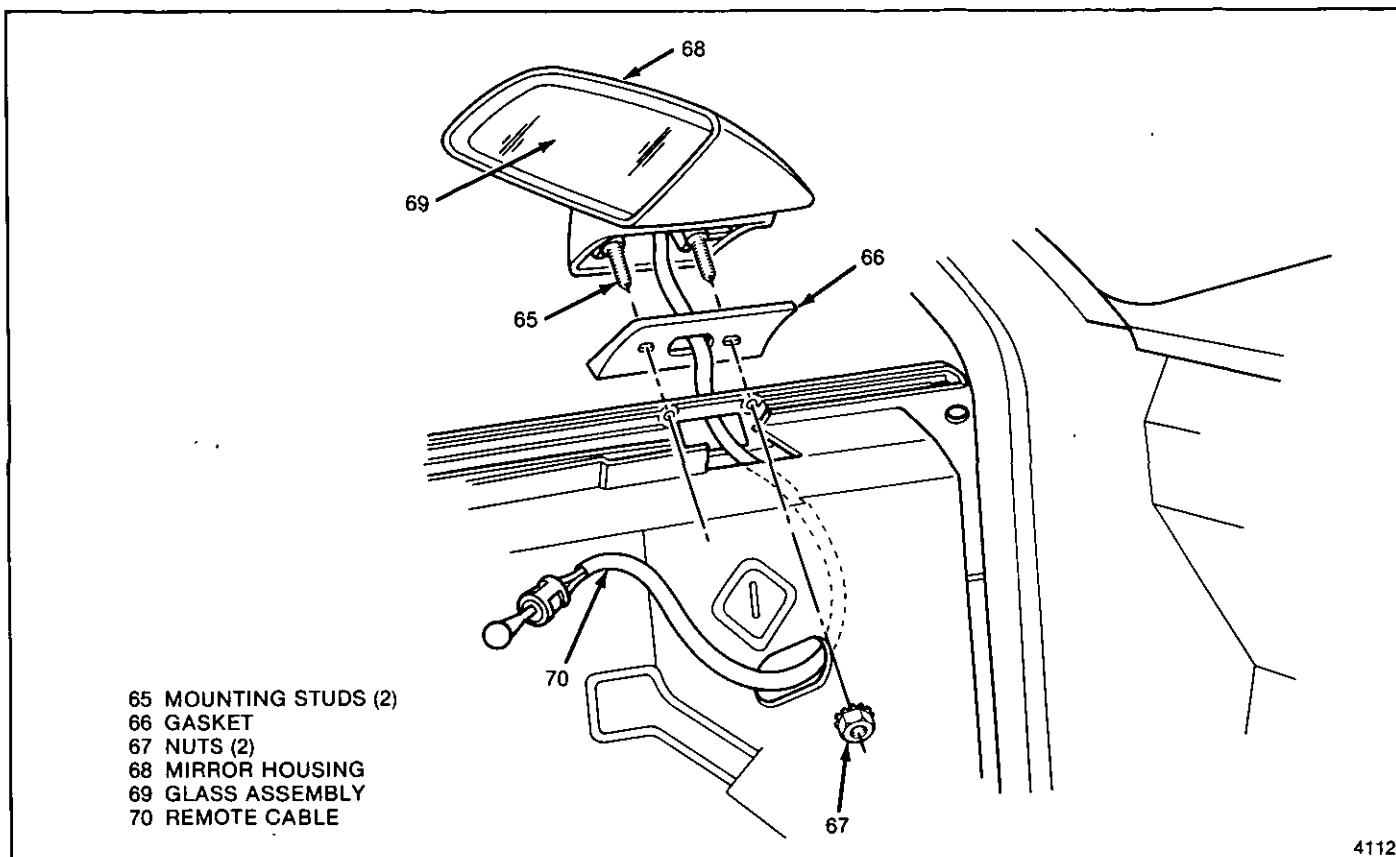

Fig. 5-20-Remote Control Mirror - Manual

### ↔ Install or Connect (Figure 5-21)

- Align both worm gear shafts on glass with drive drive gears (75)
- Press in on glass (71) until it snaps into position on pivot (74)

### 🔍 Inspect

For proper operation

### Power Mirror Drive Unit

#### ↔ Remove or Disconnect (Figure 5-21)

1. Battery (-) negative cable
2. Mirror glass (71)
3. Door trim panel
4. Front filler weatherstrip
5. Nuts (67)
6. Mirror housing (72)
7. Electrical connector (76)
8. Screws (73)
9. Drive unit

#### ↔ Install or Connect (Figure 5-21)

1. Drive unit
2. Screws (73)
3. Electrical connector (76)
4. Mirror housing (72)
5. Nuts (67)
6. Mirror glass (71)

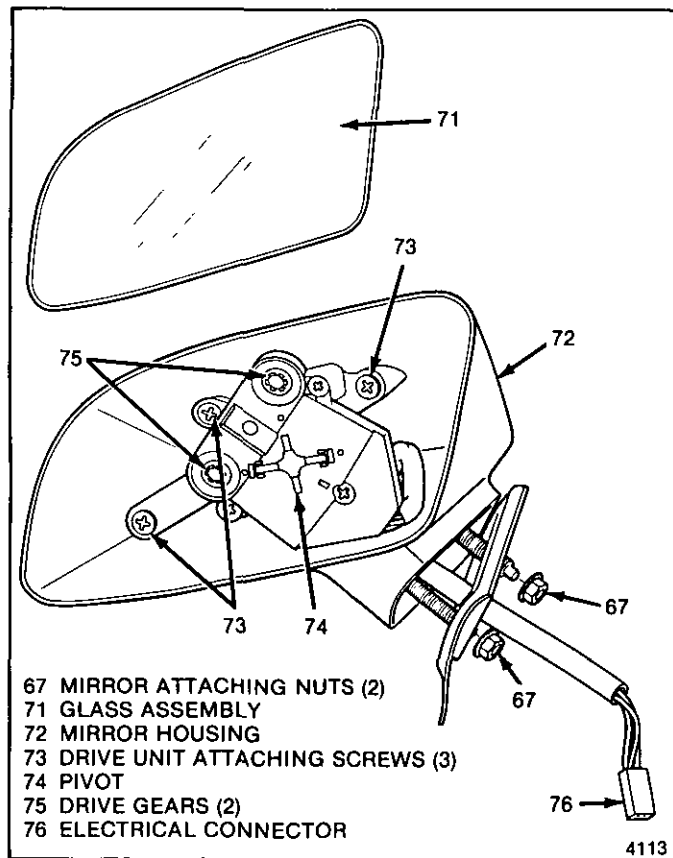

Fig. 5-21-Power Remote Outside Mirror Parts

7. Battery (-) negative cable



**Inspect**

For proper operation

8. Front filler weatherstrip
9. Door trim panel

## DOOR GLASS ASSEMBLY



**Remove or Disconnect (Figure 5-22)**

1. Door trim panel
2. Water deflector
3. Front filler sealing strip
4. Rear filler sealing strip
5. Rivets (86)
  - cam assembly
  - front stop (80)
  - rear stop (81)
6. Front and rear stops
7. Loosen door glass stabilizers
8. Remove all bushings from glass before removing glass
9. Glass (77)



**Install or Connect (Figure 5-22)**

1. Install all bushings in glass before installing glass in door.
2. Glass to cam assembly (78)
3. Front and rear stops
4. Rivets (86)
  - front stop (80)
  - rear stop (81)
  - cam assembly



**Inspect**

Window for proper operation



**Adjust**

As required

5. Rear filler sealing strip
6. Front filler sealing strip
7. Water deflector
8. Door trim panel



**Inspect**

Glass for applicable condition. Refer to applicable condition to determine the components that will require adjustment. Make adjustments only as required for correct alignment and operation. The door trim panel and water deflector must be removed for access to components.



**Adjust (Figure 5-23)**

- Window rotated
  - loosen up-stop bolts (97 and 93)
  - adjust inner panel cam-bolts (98 and 99)

- adjust up-stops
- tighten attaching bolts
- Window upper edge inboard or outboard
  - loosen front retainer bolt (87)
  - loosen rear cam guide to support bolts (92)
  - loosen rear up-stop (93)
  - loosen front and rear glass stabilizer screws (95 and 96)
  - adjust vertical guide and rear up-stop support in or out as required and tighten attaching screws
- Window too far forward or rearward
  - loosen front run channel bolts (88 and 89)
  - loosen rear cam guide assembly (90 and 91)
  - align glass in correct up position
  - tighten upper bolt on front run channel (88)
  - tighten upper bolts on rear cam guide (91)
  - lower glass
  - tighten lower bolt on front run channel (89)
  - tighten lower bolts on rear cam guide (90)
- Window too high or low in up position
  - adjust front and rear up-stop bolts (93 and 97) as required and tighten bolts.
- Window binds or has inboard-outboard movement
  - loosen glass stabilizers (95 and 96)
  - place glass in half up position
  - push stabilizers against glass with only enough pressure to eliminate inboard-outboard movement.
  - tighten glass stabilizers (95 and 96)
  - if cam channels and rollers lack lubrication, lubricate with part no. 1052196, Lubriplate Auto-Lube A (or equivalent)



**Inspect**

After making any adjustment, inspect glass for proper operation and alignment.



**Tighten**

All loosened attachments from 10 to 14 N·m (90 to 125 in-lb)

## Window Regulator Cam Assembly



**Remove or Disconnect (Figures 5-22, 5-23)**

1. Door trim panel
2. Water deflector
3. Lower glass half way and block in place.
4. Rivets from cam assembly (78)
5. Separate glass from cam assembly (78)
6. Raise glass to full-up position and block in place.
7. Window guide cam assembly bolts (90 and 91)
8. Plate (103, Fig. 5-28)
9. Rivets - regulator to inner door (9, Fig. 5-28)
10. Regulator cam assembly (78)

- 77 DOOR GLASS
- 78 CAM ASSEMBLY — REGULATOR WINDOW GLASS
- 79 STABILIZER BUTTON
- 80 FRONT UP STOP
- 81 REAR UP STOP
- 82 BUTTON OUTER
- 83 BUTTON INNER
- 84 BUSHING
- 85 RETAINER
- 86 RIVETS (1/4" DIA. x 15/16" ALUMINUM)

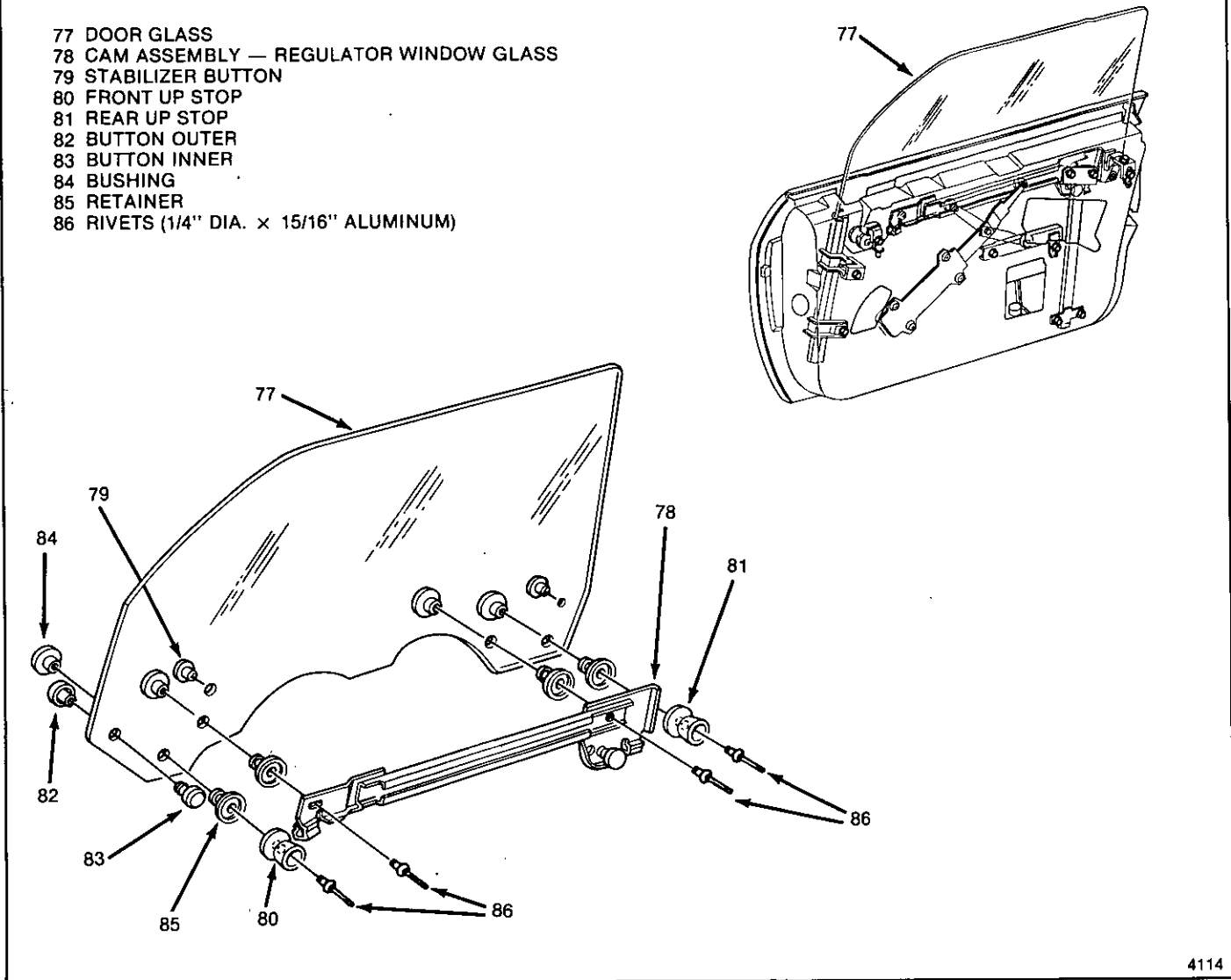

Fig. 5-22-Door Glass Assembly

4114

2. Rivets - regulator to inner door (9, Fig. 5-28)
3. Plate (103, Fig. 5-28)
4. Window guide cam assembly bolts (90 and 91)
5. Remove blocks and lower glass
6. Glass to cam assembly (78)
7. Rivets (86) glass to cam assembly

**Adjust**

Window guide assembly and tighten

**Inspect**

For proper operation

8. Water deflector
9. Door trim panel

**Regulator Assembly - Manual****Remove or Disconnect (Figure 5-24)**

1. Put glass in full-up position and block into place
2. Window regulator cam assembly

3. Cam assembly - front door inner panel (101)
4. Bell crank and bracket assembly
5. Rivets (9) from regulator
6. Regulator (100) through rear access hole

**Install or Connect (Figure 5-24)**

1. Regulator (100)
2. Rivets (9) - regulator to inner door
3. Cam assembly - front door inner panel (101)
4. Bell crank and bracket assembly
5. Window regulator cam assembly
6. Remove block from glass and check operation

**Regulator Assembly - Power****Remove or Disconnect (Figure 5-25)**

1. Put glass in full-up position and block into place
2. Window regulator cam assembly
3. Cam assembly - front door inner panel (101)
4. Bell crank and bracket assembly
5. Rivets (9) - from regulator

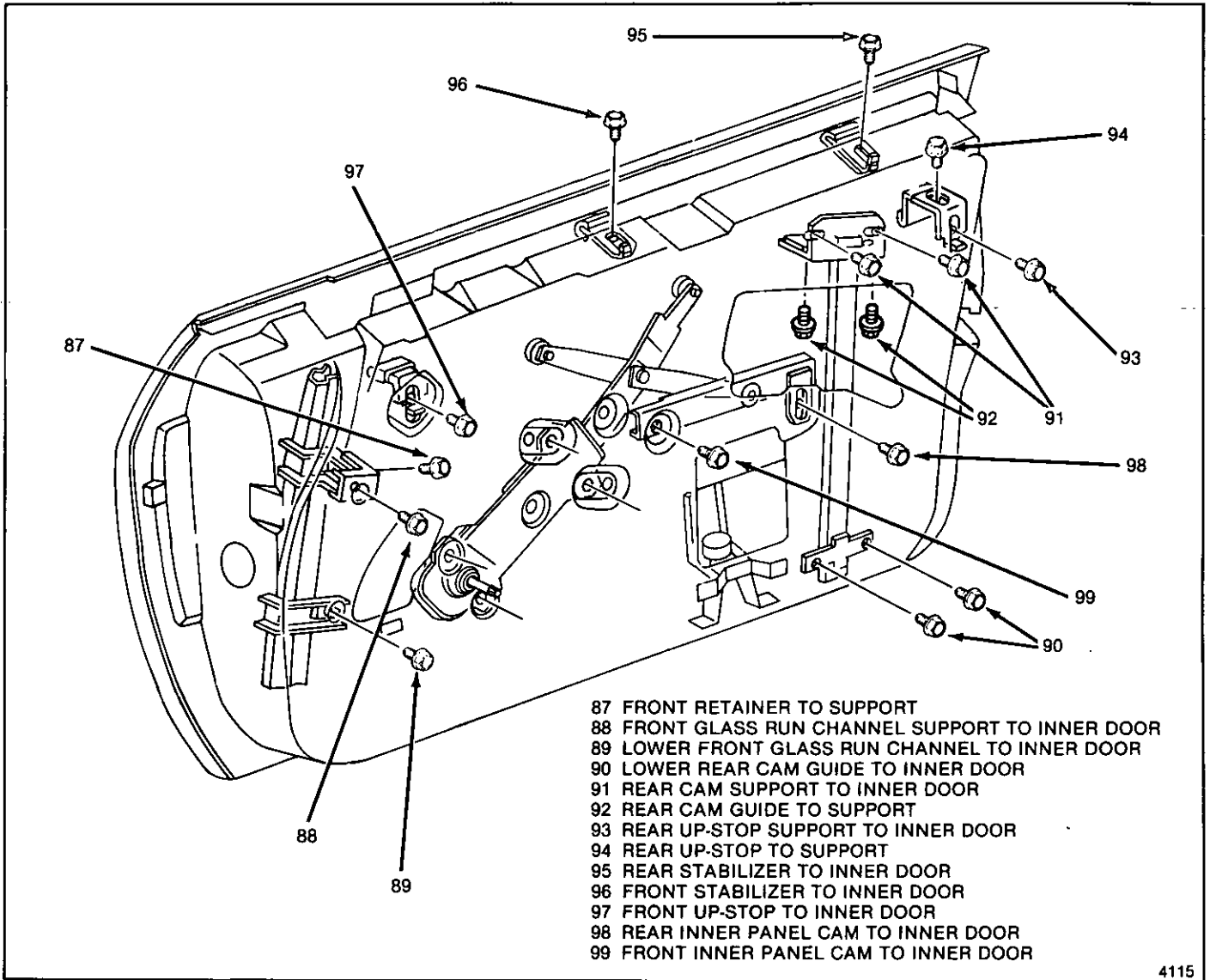

4115

Fig. 5-23-Door Hardware Attaching Bolts

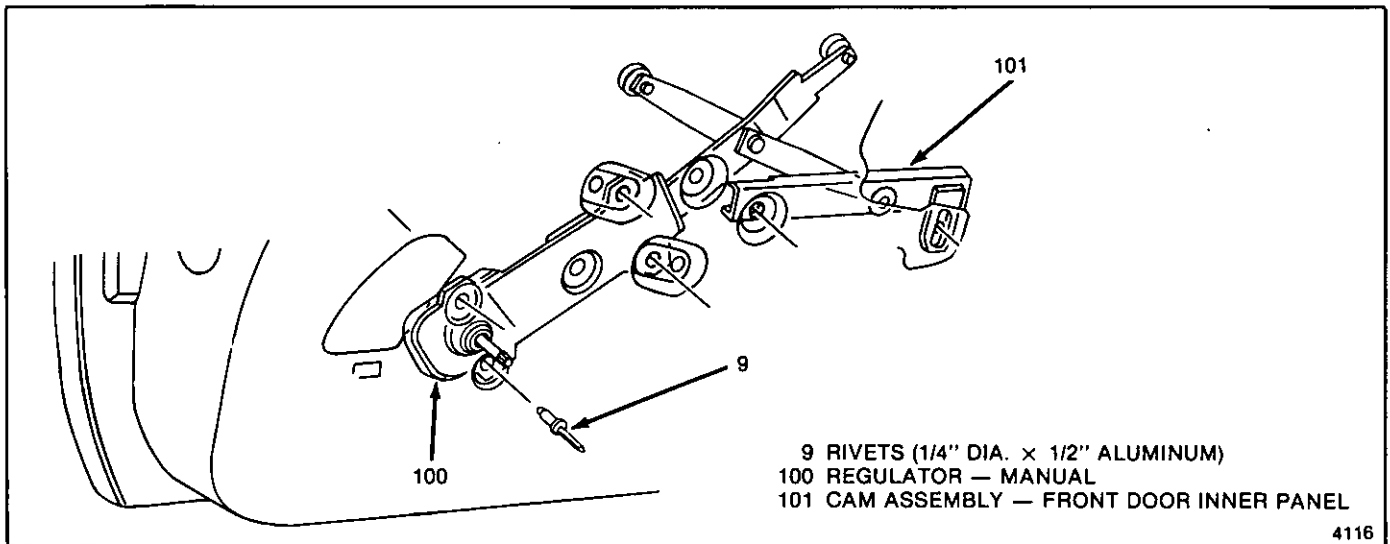

4116

Fig. 5-24-Window Regulator Assembly - Manual

6. Electrical connector
7. Regulator - electric (102) through rear access hole

**↔ Install or Connect (Figure 5-25)**

1. Regulator - electric (102)
2. Rivets (9) - regulator to inner door
3. Electrical connector
4. Cam assembly - front door inner panel (101)
5. Bell crank and bracket assembly
6. Window regulator cam assembly
7. Remove block from glass and check operation

### Rear Cam

**↔ Remove or Disconnect (Figure 5-23)**

1. Trim panel
2. Water deflector
3. Rear cam guide bolts (90, 91 and 92)
4. Rear cam guide

**↔ Install or Connect (Figure 5-23)**

1. Rear cam guide
2. Rear cam guide bolts (90, 91 and 92)



**Adjust**

Cam assembly and tighten all bolts



**Inspect**

For proper operation

3. Water deflector
4. Trim panel

### Front Glass Run Channel Assembly and Support Assembly

**↔ Remove or Disconnect (Figure 5-23)**

1. Trim panel
2. Water deflector

3. Retainer support bolts (87 and 88)
4. Front glass run channel support bolt (89)
5. Front glass run channel

**↔ Install or Connect (Figure 5-23)**

1. Front glass run channel
2. Front glass run channel bolt (89)
3. Retainer support bolts (87 and 88)



**Adjust**

Run channel and tighten bolts



**Inspect**

For proper operation of glass

4. Water deflector
5. Trim panel

### Cam Assembly - Front Door Inner Panel

**↔ Remove or Disconnect (Figure 5-23)**

1. Trim panel
2. Water deflector
3. Inner panel cam assembly bolts (98 and 99)
4. Inner panel cam assembly

**↔ Install or Connect (Figure 5-23)**

1. Inner panel cam assembly
2. Inner panel cam assembly bolts (98 and 99)



**Adjust**

Cam assembly and tighten bolts



**Inspect**

For proper operation of glass.

3. Water deflector
4. Trim panel

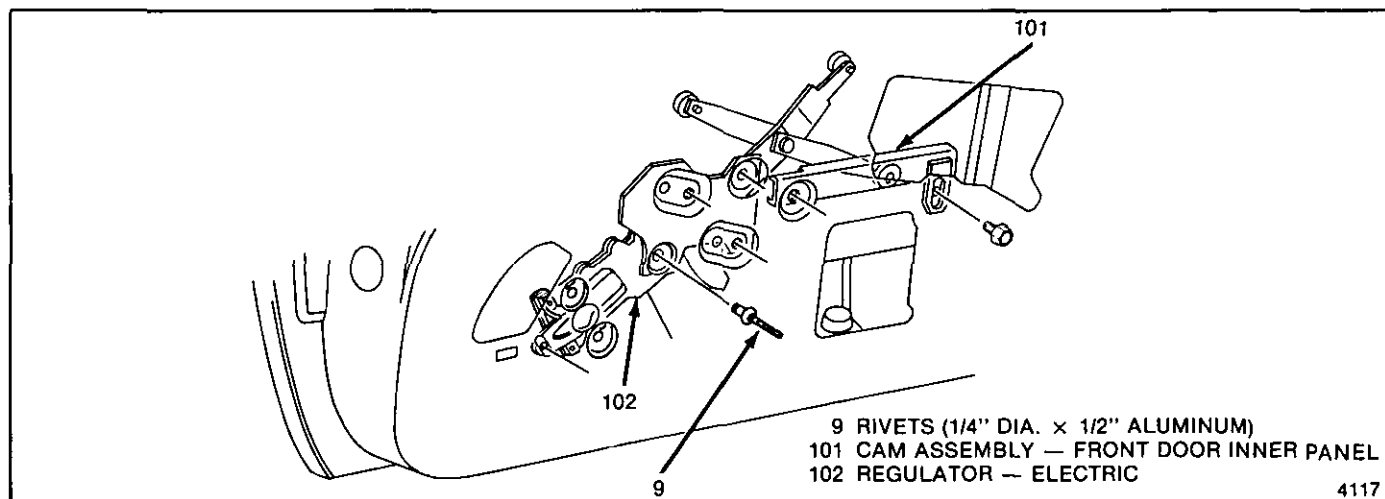

Fig. 5-25-Window Regulator Assembly - Electric

**DOOR LOCK ASSEMBLY**

Do not attempt to correct lock discrepancies. Make correction through replacement of the lock assembly.

**↔ Remove or Disconnect (Figure 5-27)**

1. Trim panel
2. Water deflector
3. Rods at lock assembly
4. Door ajar switch wire connector from main harness (54C, Fig. 5-26)
5. Lock assembly screws – lower assembly to disengage outside handle lock rod (50)
6. Lock assembly (54)

**↔ Install or Connect (Figure 5-27)**

1. Spring clip on lock assembly
2. Lock assembly (54)
3. Rods at lock assembly (50)
4. Lock assembly screws

**⊞ Tighten**

9 to 11 N·m (80 to 100 in-lb)

**⊞ Inspect**

For proper operation

5. Door ajar switch wire connector to main harness (54C, Fig. 5-26)
6. Water deflector
7. Trim panel

**DOOR AJAR SWITCH****↔ Remove or Disconnect (Fig. 5-26)**

1. Trim panel
2. Water deflector
3. Lock assembly
4. Screw (54B)
5. Switch (54A)

**↔ Install or Connect**

1. Switch (54A) to lock assembly by engaging lower lip of switch onto lower edge of lock attaching tab
2. Screw (54B)
3. Lock assembly
4. Water deflector
5. Trim panel

**Lock Cylinder Assembly****↔ Remove or Disconnect (Figure 5-27)**

1. Trim panel  
Water deflector  
Loosen top portion of outer door panel

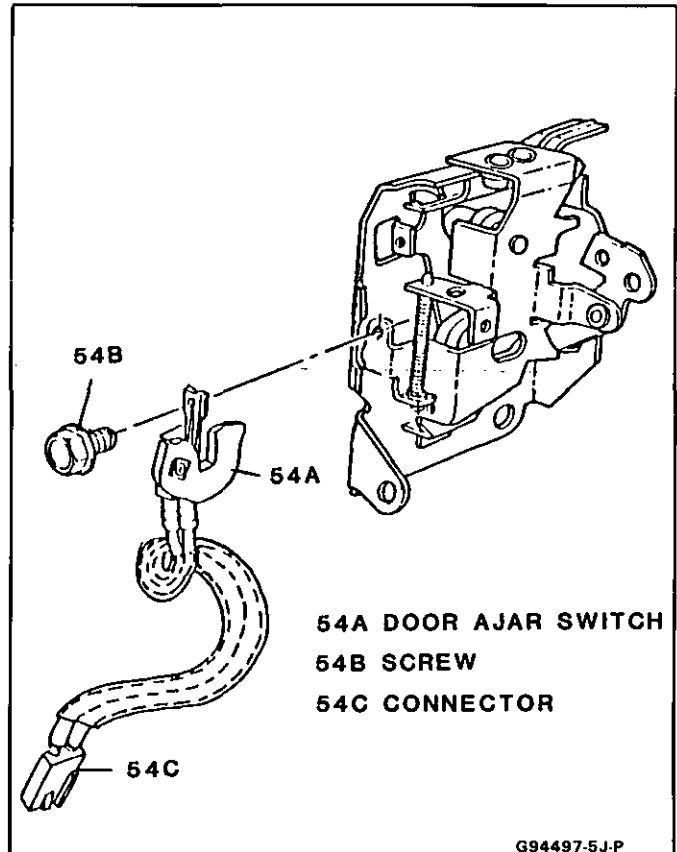

Fig. 5-26 - Installing Door Ajar Switch

**↔ Install or Connect (Figure 5-27)**

1. Lock cylinder assembly (51)
2. Cylinder assembly retainer (53)
3. Top portion of outer door panel
4. Water deflector
5. Trim panel

**POWER DOOR LOCK SYSTEMS**

The power door lock system has a motor actuator in each door. A rod connects the actuator to the bell crank. A rod on the bell crank goes to the lock assembly. The system is actuated by a switch in each door trim panel. All doors lock and unlock at the same time from either control switch. Each lock can also be operated manually by sliding the locking knob in the desired direction. The locking knob shows red when in the unlocked position. Each actuator has an internal circuit breaker which may require one to three minutes to reset.

**Power Lock Actuator****↔ Remove or Disconnect (Figure 5-28)**

1. Trim panel
2. Water deflector
3. Electrical connector
4. Rivets (9)



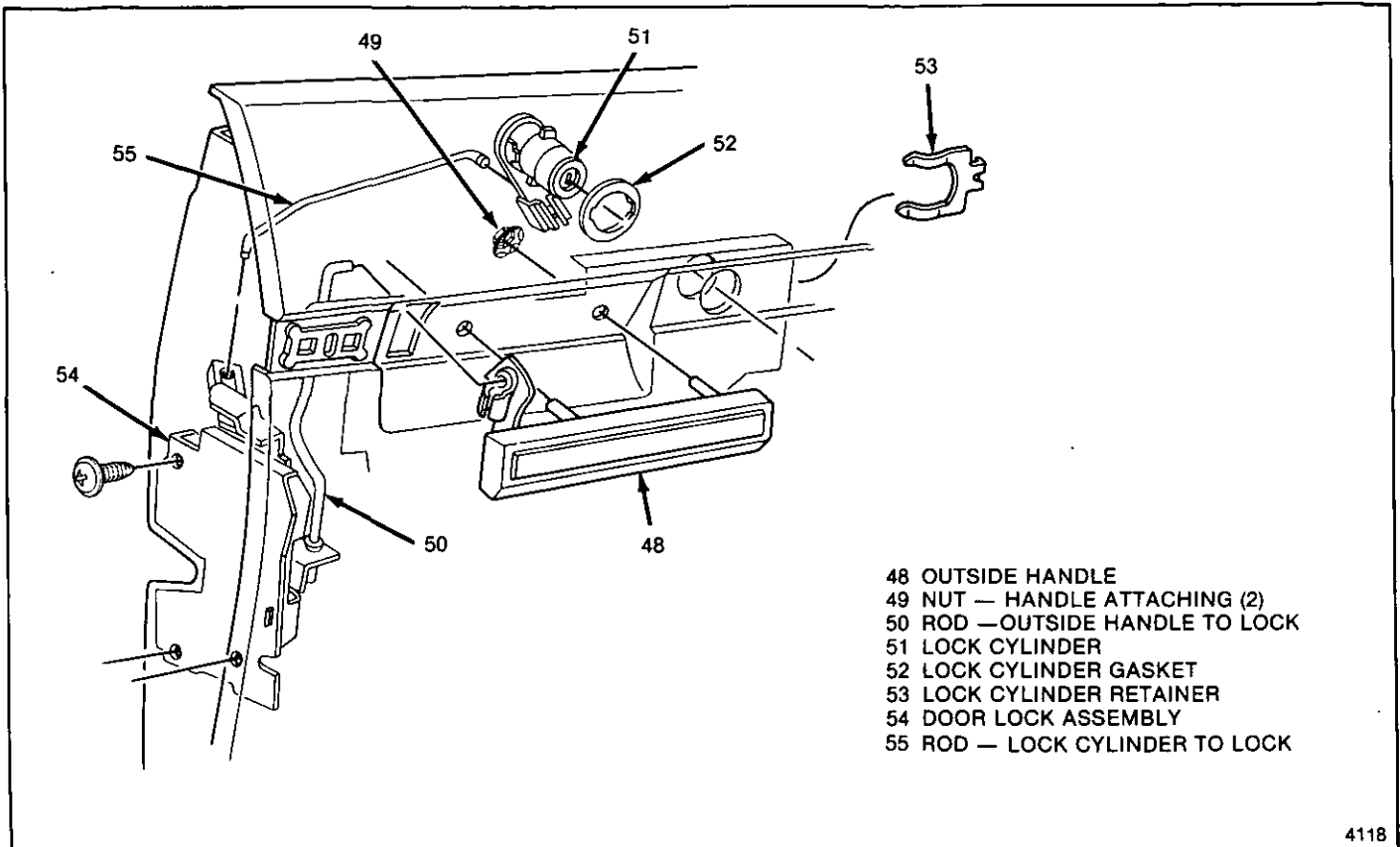

Fig. 5-27-Door Locking Mechanism

4118

### ↔ Install or Connect (Figure 5-28)

1. Actuator assembly (41)
2. Actuator rod at bell crank (104)
3. Rivets (9)
4. Electrical connector

### 🔍 Inspect

For proper operation

5. Water deflector
6. Trim panel

### DOOR BELL CRANK

### ↔ Remove or Disconnect (Figures 5-11 and 5-28)

1. Trim panel
2. Water deflector
3. Put glass in full-up position
4. Rivets at bell crank plate assembly (44)
5. All rod assemblies
6. Bell crank and plate assembly (103)

### ↔ Install or Connect

1. Bell crank and plate assembly (103)
2. All rod assemblies
3. Rivets at bell crank plate assembly (44)

### 🔍 Inspect

For proper operation

4. Water deflector

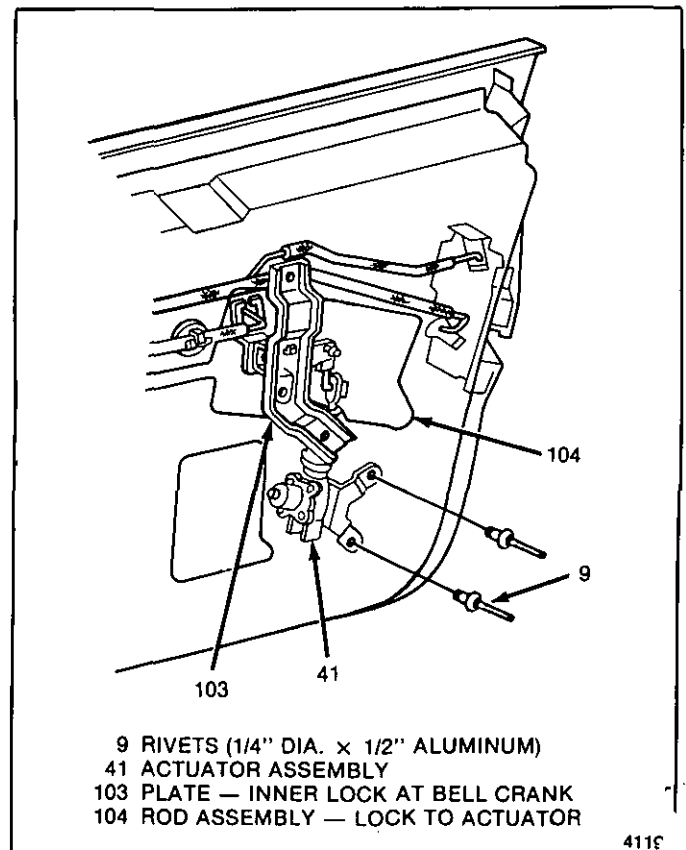

Fig. 5-28-Power Door Lock System

4119

## 5. Trim panel

**DOOR HINGE SYSTEM**

**NOTICE:** The door hinge components are important attaching parts in that they could affect the performance of vital components and systems and/or could result in major repair expense. Each part must be replaced with one of the same part number or with an equivalent part if replacement becomes necessary. Do not use replacement parts of lesser quality or substitute design. Torque values must be used as specified during reassembly to assure proper retention of this part.

This portion of the manual contains the service operations necessary to remove the doors, the door side hinge straps and the body hinge straps.

**Door****↔ Remove or Disconnect (Figure 5-29)**

1. Door trim panel
2. Water deflector
3. Front run channel
4. Outer door panel assembly
5. Upper and lower hinge strap bolts to door side (107 and 110)
6. Wiring harness conduit at body and pull wiring harness through body (if equipped). Use aid of a second person to hold door.

**↔ Install or Connect (Figure 5-29)**

1. Two bolts at upper hinge strap (107). Coat strap surface that mates with door and bolt threads with sealer. Use aid of second person to hold door.
2. Two bolts at lower hinge strap (110). Coat strap surface that mates with door and bolt threads with sealer.
3. Outer door panel assembly.
4. Wiring harness conduit. Pull harness through body (if equipped).
5. Wiring harness (if equipped)

**🔍 Inspect**

Prior to closing door completely, inspect for proper door assembly engagement at striker and correct door panel clearance with fender panel. The clearance between door panel and fender panel should be no more than 4 mm (5/32").

**🔧 Tighten**

Hinge bolts from 20 to 28 N·m (14 to 20 ft-lb)

**🔍 Inspect**

Door assembly for proper engagement

- electrical door devices for proper operation

## 8. Door trim panel

**DOOR HINGE****↔ Remove or Disconnect (Figure 5-29)****! Important**

Open door to the full-open position and support it. Mark the location of the hinge straps at the body and door before removal.

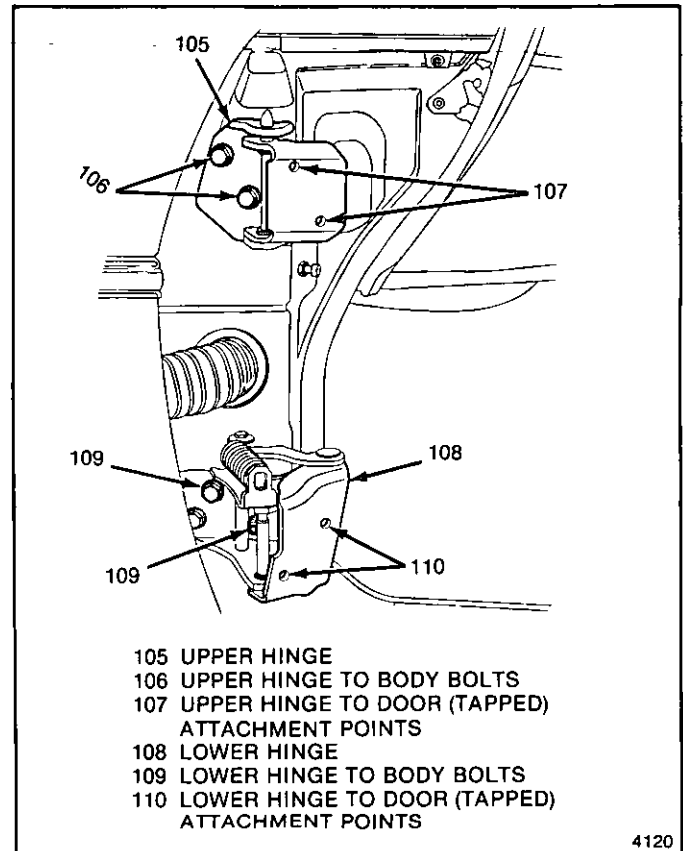

Fig. 5-29-Door Hinges

1. Outer door panel assembly
2. Lower garnish molding
3. Peel back noise control adhesive patch
4. Lower hinge strap bolts from inside body
5. Hinge strap bolts from outside of body
6. Hinge assembly (105 or 108)

**! Important**

The service body side hinge straps have only one bolt hole. To locate the other bolt hole, use the original hinge strap to make a paper template.

- Outline hinge strap on a piece of paper
  - Locate centerline of required new hole
  - Push pen through paper template at this location
  - Place template on service hinge and align template with hinge
  - Center punch hole location
  - Drill new hole with a 8.5 mm (11/32") drill bit.
- The holes in the body pillar will provide for some

 **Install or Connect (Figure 5-29)**

1. Hinge assembly (105 or 108). Coat surface of hinge strap that mates with body pillar with medium-bodied sealer.
2. Bolts – hinge to body (106 or 109)
3. Bolts – hinge to door (107 or 110)

 **Important**

Align hinge with marks previously made on body and door.

 **Tighten**

- 8 mm bolts from 20 to 28 N·m (15 to 20 ft-lb)
  - 10 mm bolt from 40 to 55 N·m (30 to 40 ft-lb)
4. Outer door panel assembly

 **Inspect**

- Door assembly engagement at striker – adjust where necessary.
  - Clearance between door panel and fender panel – no more than 4 mm (5/32").
5. Noise control adhesive patch
  6. Lower garnish molding

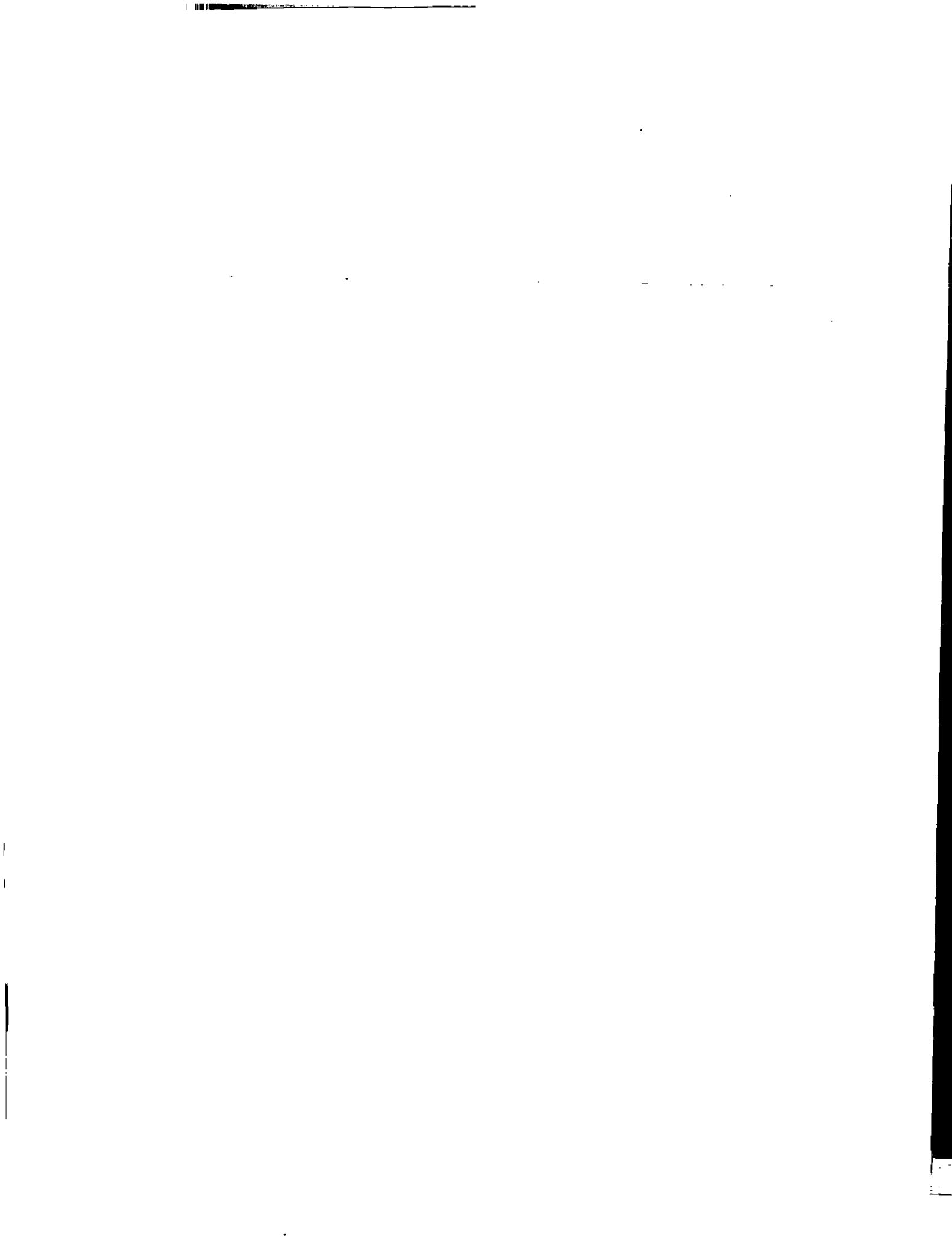

## SECTION 6

# REAR QUARTERS

**NOTICE:** Care must be taken when servicing any fiberglass (SCM) panel or component. Fasteners retaining such panels or components must be hand started to prevent damage to fiberglass parts. Always use the specified torque values given for SMC parts to assure safe and proper retention.

## CONTENTS

Quarter Trim .....	6-1	Lower Pressure Relief Valve .....	6-5
Rocker Panel Cover .....	6-1	Applique Panel Assembly .....	6-5
Extensions - Rocker Panel Cover .....	6-1	Upper Pressure Relief Valve .....	6-6
Rear Compartment Side Panel Cover .....	6-2	Fuel Tank Filler Door .....	6-7
Rear Compartment Cover Extension, 37 Style .....	6-2	Locking Fuel Filler Door and Pocket Assembly .....	6-7
Back Window Side Filler Panel, 37 Style .....	6-2	Fuel Filler Door Remote Latch and Cable Assembly .....	6-7
Back Window to Quarter Filler Panel, 97 Style .....	6-2	Exterior Panels and Moldings .....	6-7
Rear Quarter Trim Panel .....	6-3	Rear Wheelhouse Panel .....	6-7
Speaker Assembly .....	6-3	Rear Fender Finish Molding .....	6-7
Speaker Grille .....	6-4	Rear Fender Panel Assembly .....	6-9
		Rear Roof Panel Assembly .....	6-9

### QUARTER TRIM

#### ROCKER PANEL COVER

##### Remove or Disconnect (Figure 1)

1. Two wheelhousing screws (1)
2. Cover plates (2)
3. Three rivets (3) under cover plates (2)
4. Seven rivets (3) from rocker panel (4)
5. Rocker Panel (4)

##### Install or Connect (Figure 1)

1. Rocker panel (4)
2. Seven rivets (3) to rocker panel (4)
3. Three rivets (3) under cover plates (2)
4. Cover plates (2)
5. Two wheelhousing screws (1)

#### EXTENSION - ROCKER PANEL COVER TO DOOR PANEL

##### Remove or Disconnect (Fig. 2)

1. Rivets (1)
2. Extension by lifting up on extension (3) to disengage upper flange from clips (2) on body.

##### Install or Connect

1. Extension to door panel by placing upper flange over clips (2) and pushing down on extension.
2. Rivets (1)

#### EXTENSION - ROCKER PANEL COVER TO FRONT FENDER

##### Remove or Disconnect (Fig. 2)

1. Rocker panel cover
2. Rivet (6)
3. Extension (7) by lifting up on extension to disengage upper flange from clips (2).

##### Install or Connect

1. Extension (7) to front fender by placing upper flange over clip (2) and pushing down on extension
2. Rivet (6)
3. Rocker panel cover

#### EXTENSION - ROCKER PANEL COVER TO QUARTER

##### Remove or Disconnect (Fig. 2)

1. Rocker panel cover
2. Rivets (4)
3. Extension (5) by lifting up on extension to disengage upper flange from clips (2) on body

##### Install or Connect

1. Extension (5) to quarter panel by placing upper flange over clips (2) and pushing down on extension
2. Rivets (4)
3. Rocker panel cover

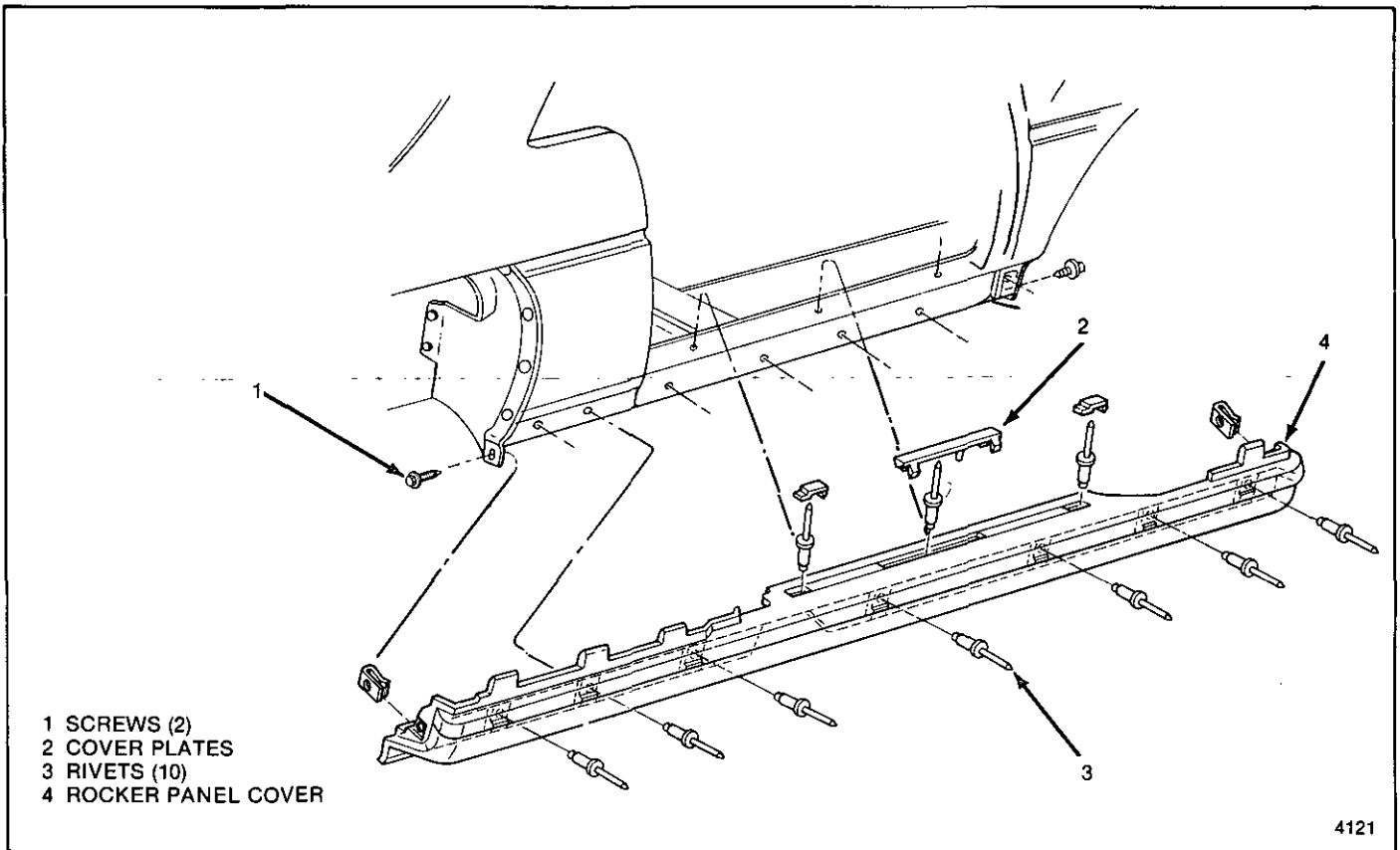

Fig. 1-Installing Rocker Panel Cover

4121

**REAR COMPARTMENT SIDE PANEL COVER**

**↔ Remove or Disconnect (Figure 3)**

1. Rear compartment lid in open position
2. Wing screw(s) – two on 37 style, one on 97 style
3. Panel (6)

**→← Install or Connect (Figure 3)**

1. Panel (6) on pins (7)
2. Wing screw(s) – two on 37 style, one on 97 style

**REAR COMPARTMENT COVER EXTENSION - 37 STYLE**

**↔ Remove or Disconnect (Figure 4)**

1. Rear compartment side panel cover
2. Two screws (10)
3. Rear compartment side panel cover hinge (11)
4. Cover extension (12)

**→← Install or Connect (Figure 4)**

1. Cover extension (12)
2. Rear compartment side panel cover hinge (11) and screw
3. Two screws (10)

**BACK WINDOW SIDE FILLER PANEL - 37 STYLE**

**↔ Remove or Disconnect (Figure 5)**

1. Rear compartment side panel cover
2. Rear compartment side cover extension
3. Upper screws (8)
4. Lower screws (9)
5. Panel

**→← Install or Connect (Figure 5)**

1. Panel
2. Lower screws (9)
3. Upper screws (8)
4. Rear compartment side cover extension
5. Rear compartment side panel cover

**BACK WINDOW TO QUARTER FILLER PANEL - 97 STYLE**

**↔ Remove or Disconnect (Fig. 6)**

1. Rear compartment side panel cover
2. Screws (10A)
3. Place cloth tape onto body next to panel
4. Filler panel (11A) by placing flat bladed tool between body and filler panel at tape locations, and prying filler panel loose from body

**→← Install or Connect**

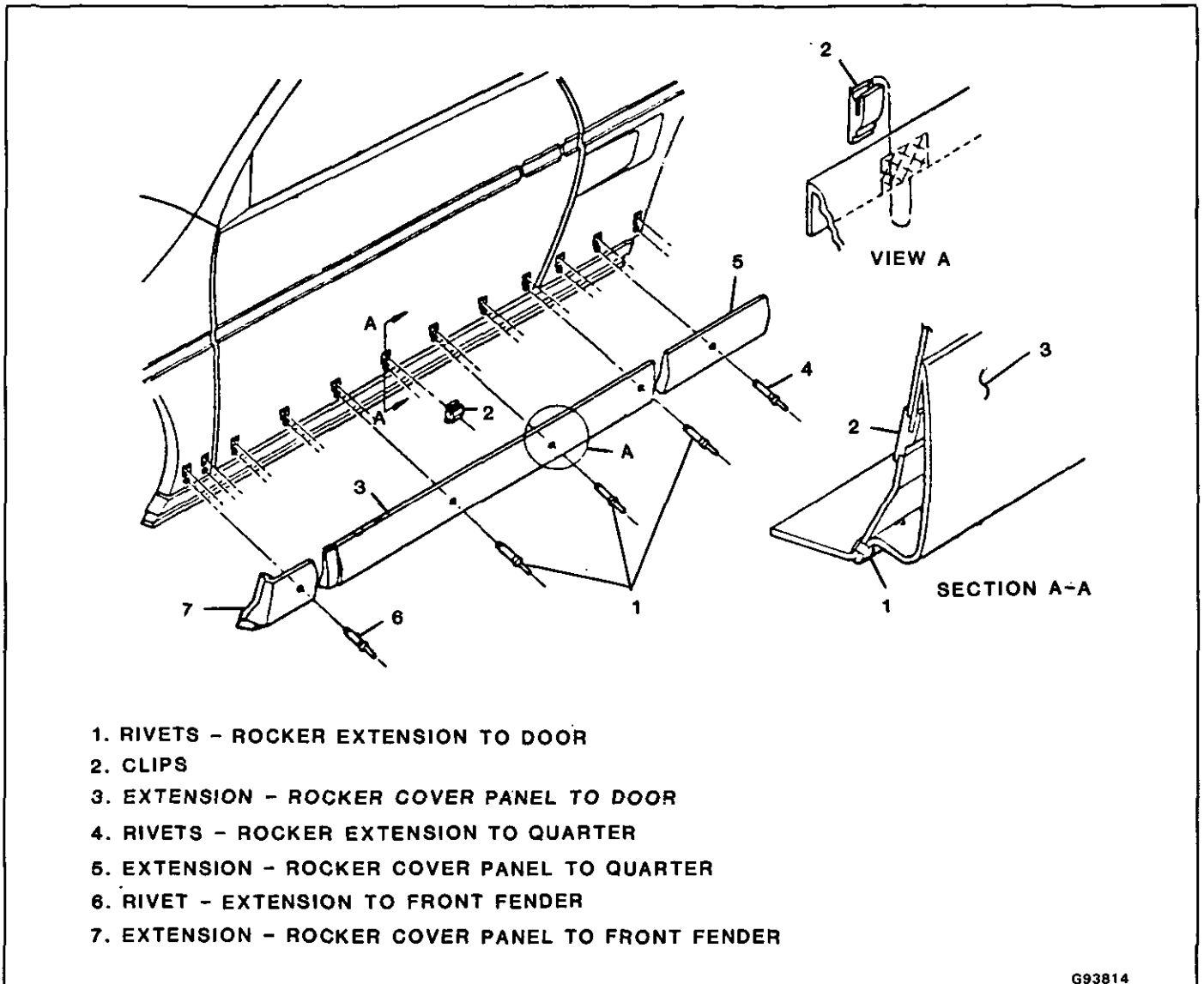

- 1. RIVETS - ROCKER EXTENSION TO DOOR
- 2. CLIPS
- 3. EXTENSION - ROCKER COVER PANEL TO DOOR
- 4. RIVETS - ROCKER EXTENSION TO QUARTER
- 5. EXTENSION - ROCKER COVER PANEL TO QUARTER
- 6. RIVET - EXTENSION TO FRONT FENDER
- 7. EXTENSION - ROCKER COVER PANEL TO FRONT FENDER

G93814

Fig. 2 - Extensions - Rocker Panel Cover

- 2. Filler panel (11A)
- 3. Screws (10A)
- 4. Rear compartment side panel cover
- 5. Cloth tape from body

- 4. Upper shoulder belt anchor assembly



Tighten

Anchor bolt 35 to 48 N·m (26 to 35 ft-lb)

### REAR QUARTER TRIM PANEL

The rear quarter trim panel is a one-piece plastic assembly. The panel fits into the seatback-to-motor compartment panel.

#### ↔ Remove or Disconnect (Figure 7)

- 1. Upper shoulder belt anchor assembly
- 2. Screw (13)
- 3. Panel (14). Unseat retainer clip by grasping panel with hands and pulling inward.
- 4. Seat belt webbing from slots (15) on panel (14)

#### →← Install or Connect (Figure 7)

- 1. Seat belt webbing through slots (15) on panel (14)
- 2. Panel (14). Apply pressure at retainer location
- 3. Screw (13)

### SPEAKER ASSEMBLY

#### ↔ Remove or Disconnect (Fig. 8)

- 1. Rear quarter trim panel
- 2. Screws (13A)
- 3. Speaker assembly (14A)
- 4. Connector (15A) from connector (16A)

#### →← Install or Connect

- 1. Connector (15A) to connector (16A)
- 2. Speaker assembly (14A)
- 3. Screws (12A)
- 4. Rear quarter trim panel

## 6.4 REAR QUARTERS

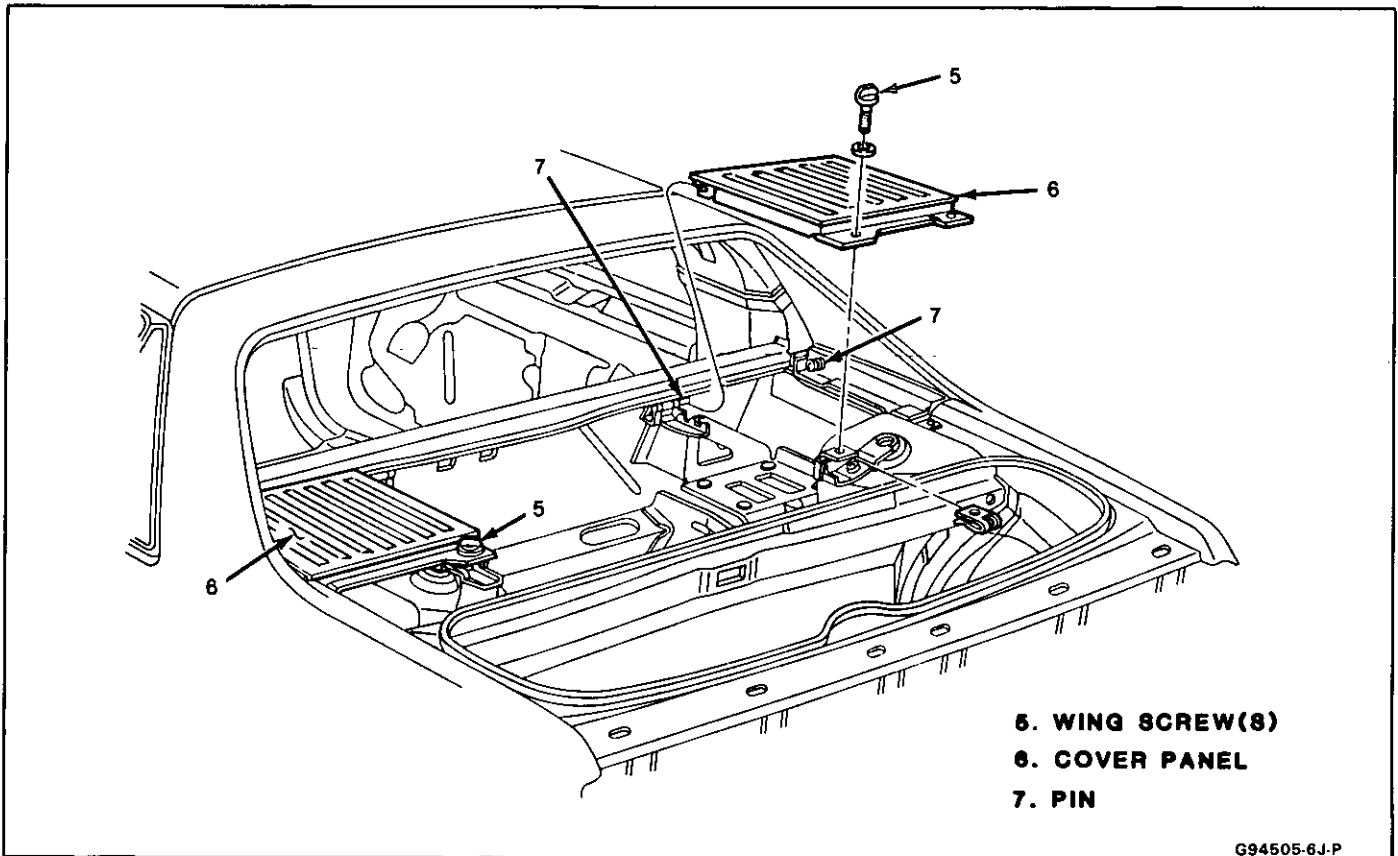

Fig. 3-Installing Rear Compartment Side Panel Cover - 37 Style Shown, 97 Style Similar

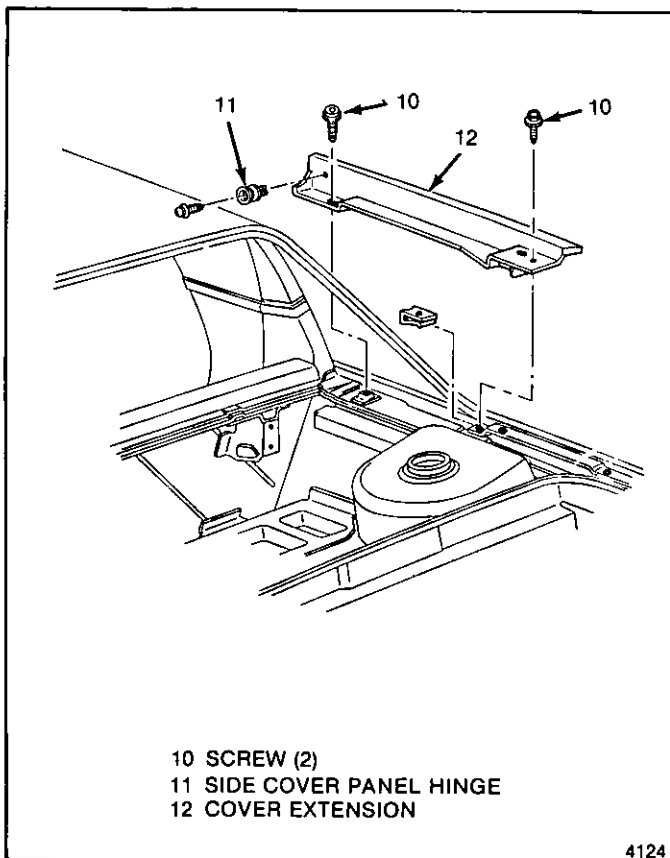

Fig. 4 Rear Compartment Cover Extension - 37 Style

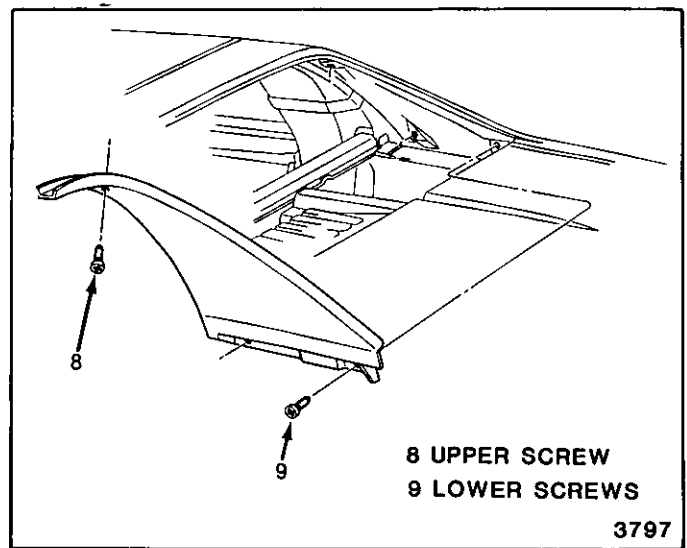

Fig. 5 Back Window Side Filler Panel - 37 Style

### SPEAKER GRILLE

↔ Remove or Disconnect

1. Rear quarter trim panel
2. Speaker grille by placing trim panel face down on protected surface and disengaging grille retainers from trim panel

→< Install or Connect



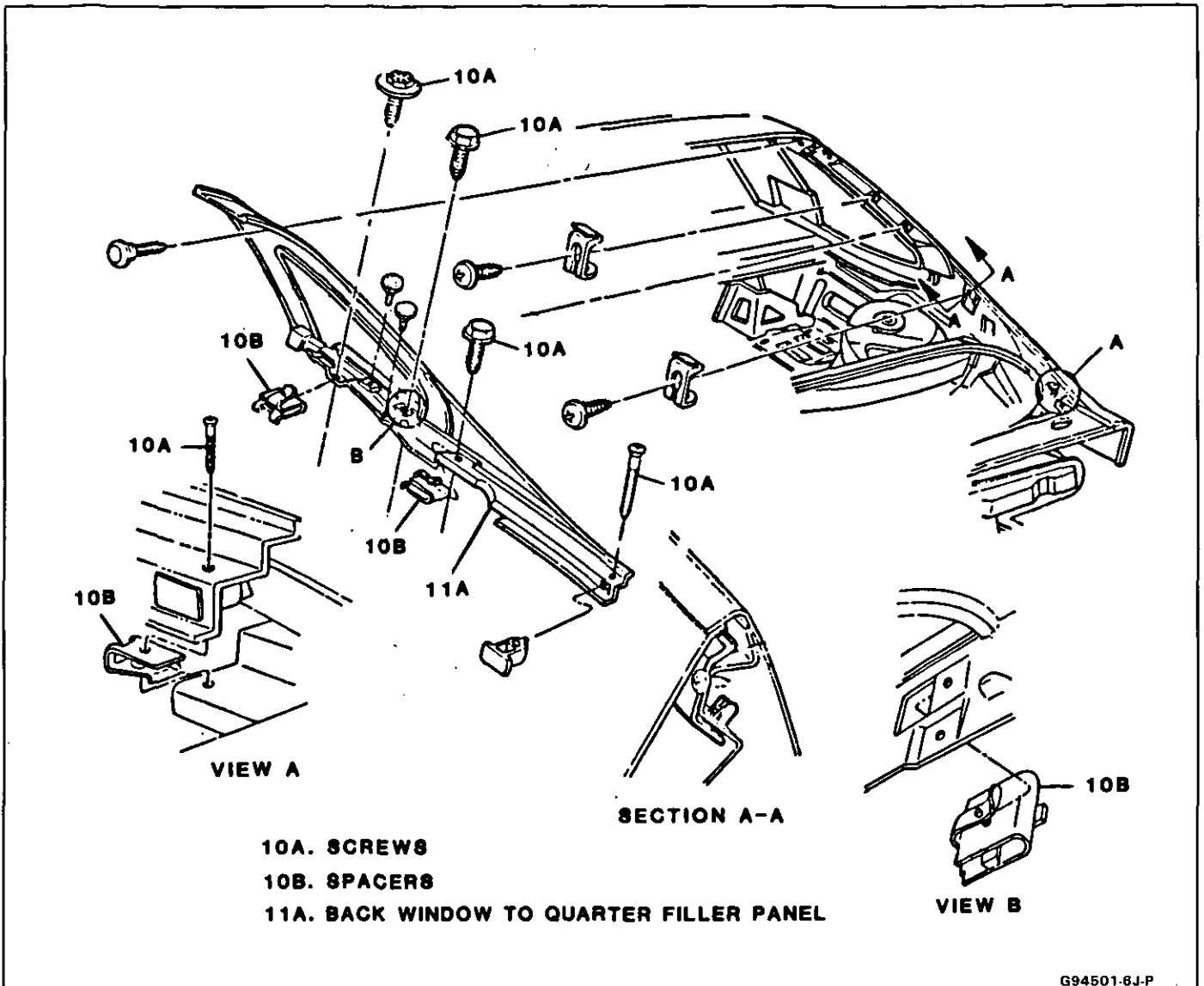

Fig. 6 - Installing Back Window to Quarter Filler Panel - 97 Style

G94501-6J-P

### LOWER PRESSURE RELIEF VALVE

**↔** Remove or Disconnect (Figure 9)

1. Upper shoulder belt anchor assembly
2. Rear quarter trim panel
3. Four screws (17)
4. Valve (18)

**↔** Install or Connect (Figure 9)

1. Valve (18)
2. Four screws (17)
3. Rear quarter trim panel
4. Upper shoulder belt anchor assembly

**⌚** Tighten

Anchor bolt 35 to 48 N·m (26 to 35 ft-lb)

### APPLIQUE PANEL ASSEMBLY

**↔** Remove or Disconnect (Figure 10)

1. Upper shoulder belt anchor assembly
2. Rear quarter trim panel
3. Hex nut (19)
4. Grasp panel at front and pull outboard. Do not pull out more than one inch while sliding it rearward to dislodge the spring clip from the panel.

**↔** Install or Connect (Figure 10)

1. Two retainer clips (21) to roof panel
2. Panel (20)
3. Hex nut (19)
4. Rear quarter trim panel
5. Upper shoulder belt anchor assembly

**⌚** Tighten

Anchor bolt 35 to 48 N·m (26 to 35 ft-lb)

## 6-6 REAR QUARTERS

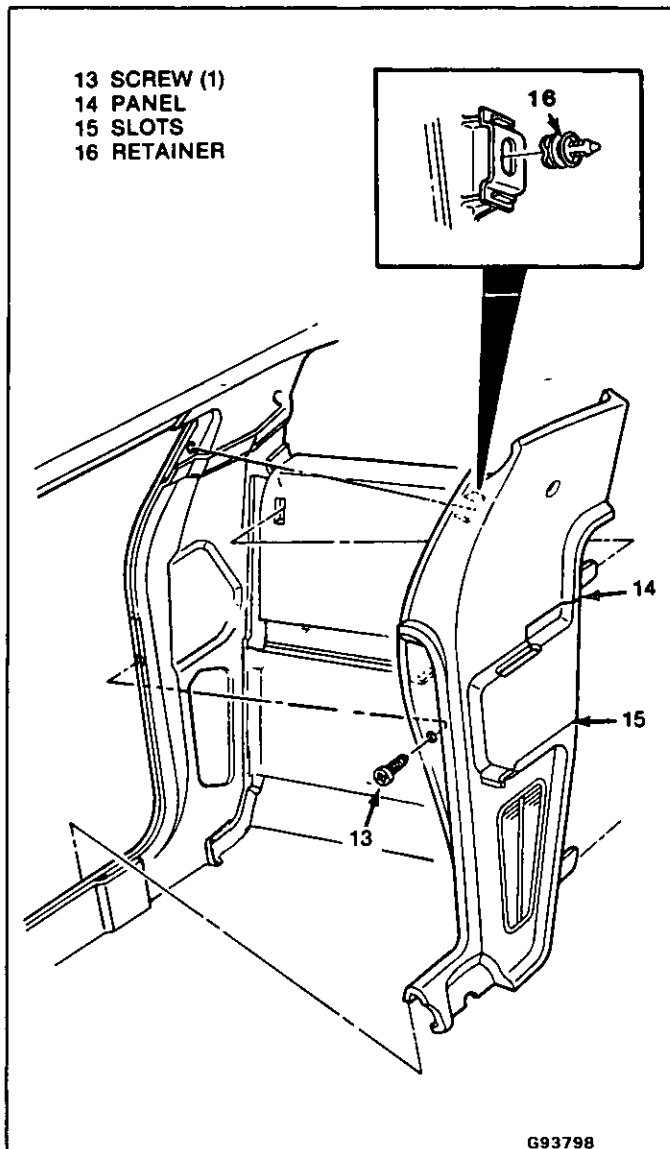

Fig. 7-Rear Quarter Trim Panel

### UPPER PRESSURE RELIEF VALVE

**↔** Remove or Disconnect (Figure 11)

1. Upper shoulder belt anchor assembly
2. Rear quarter trim panel
3. Applique panel assembly
4. Screw (23)
5. Valve (24)

**↔** Install or Connect (Figure 11)

1. Valve (24)
2. Screw (23)
3. Applique panel assembly
4. Rear quarter trim panel
5. Upper shoulder belt anchor assembly

**⏪** Tighten

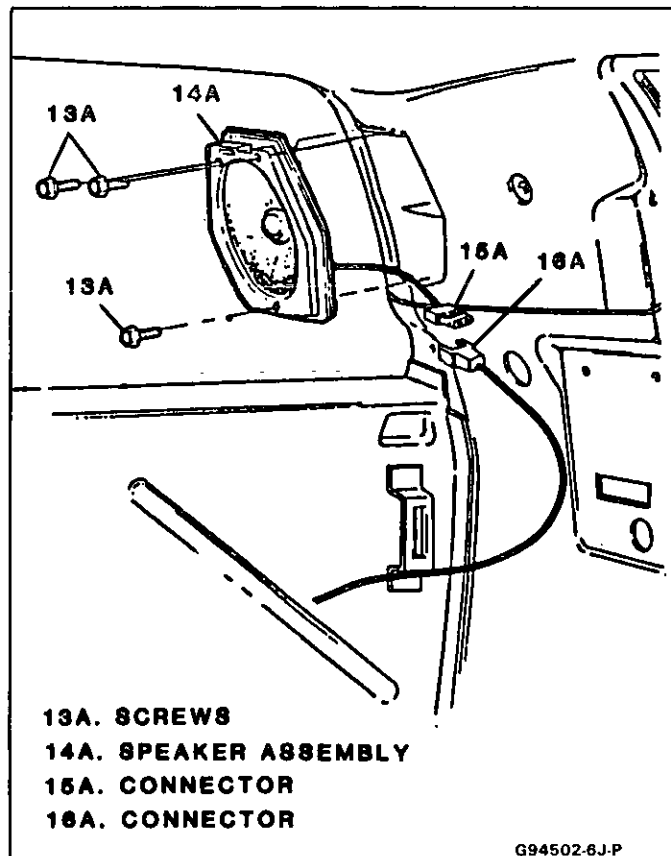

Fig. 8 - Installing Quarter Speaker Assembly

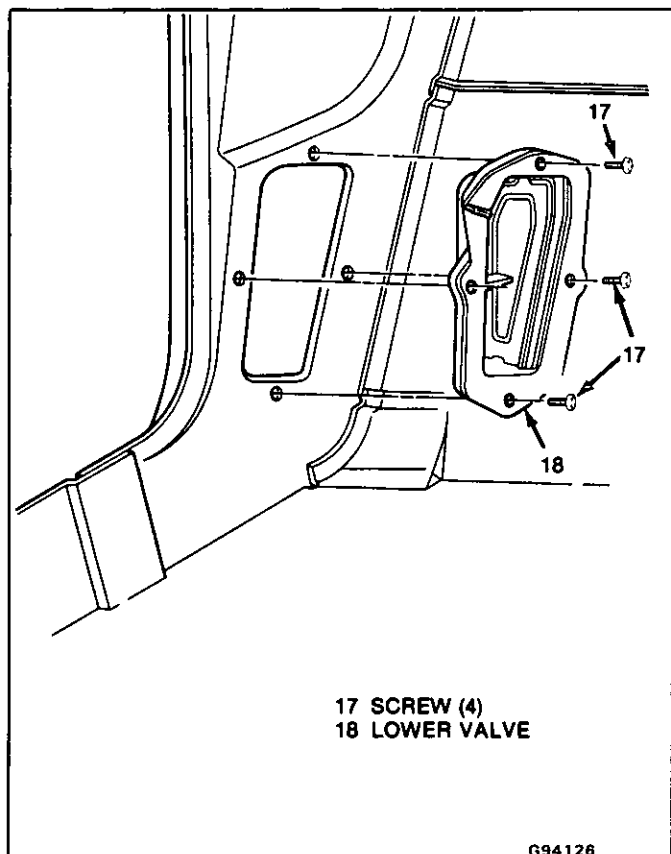

Fig. 9-Lower Pressure Relief Valve

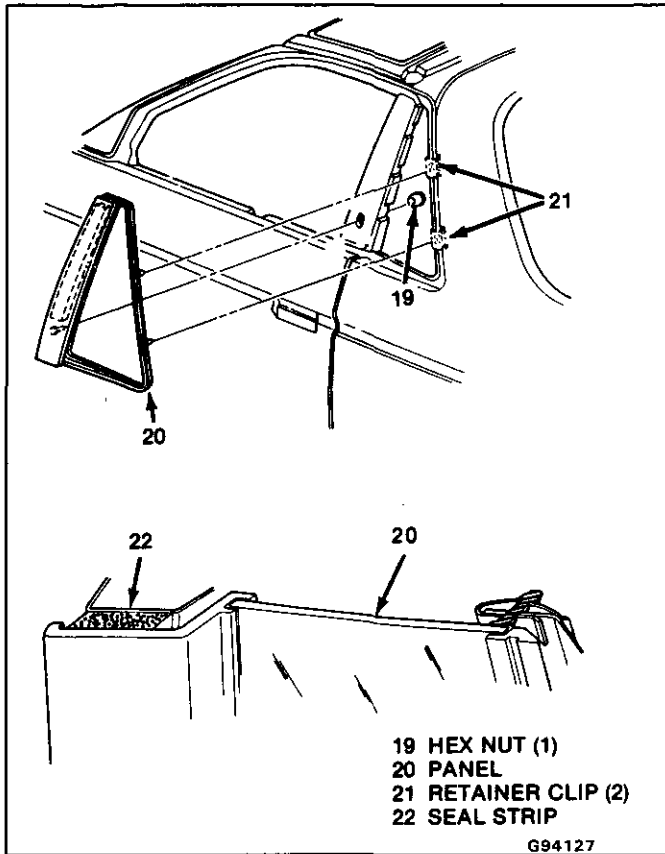

Fig. 10-Applique Panel Assembly

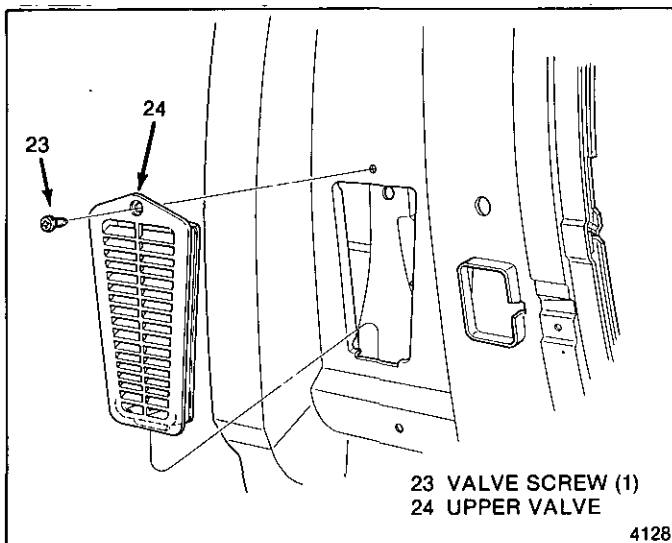

Fig. 11-Upper Pressure Relief Valve

## FUEL TANK FILLER DOOR

### LOCKING FUEL FILLER DOOR AND POCKET ASSEMBLY

#### ↔ Remove or Disconnect (Figure 12)

1. Two filler door hinge screws
2. Filler door (25)
3. Two pocket screws
4. Latch screw (26)
5. Latch (27)

6. Cable (28) from latch (27)
7. Pocket (29)

#### ↔ Install or Connect (Figure 12)

1. Cable (28) through pocket (29)
2. Pocket (29) and pocket screws
3. Cable (28) to latch (27)
4. Latch (27) and latch screw (26)
5. Filler door (25) and hinge screws

### FUEL FILLER DOOR REMOTE LATCH AND CABLE ASSEMBLY

#### ↔ Remove or Disconnect (Figures 12 and 13)

1. Fuel filler door (25)
2. Latch (27) and cable (28) from latch
3. Upper shoulder belt anchor assembly
4. Rear quarter trim panel
5. Latch release screw and handle (30)
6. Applique panel assembly
7. Screw and bracket (31)
8. Cable (28) from handle (30)

#### ↔ Install or Connect (Figure 12 and 13)

1. Cable (28) in body
2. Bracket (31) and screw
3. Cable (28) to handle (30)
4. Applique panel assembly
5. Latch release handle (30) and screw
6. Rear quarter trim panel
7. Upper shoulder belt anchor assembly

#### ⌚ Tighten

Anchor bolt from 35 to 48 N·m (26 to 35 ft-lb)

8. Cable (28) and latch (27)
9. Latch (27) and fuel filler door (25)

## EXTERIOR PANELS AND MOLDINGS

### REAR WHEELHOUSE PANEL

#### ↔ Remove or Disconnect (Figure 14)

1. Six push-pull retainers (32)
2. Eight attaching screws (33)
3. Panel (34)

#### ↔ Install or Connect (Figure 14)

1. Panel (34)
2. Eight attaching screws (33)
3. Six push-pull retainers (32)

**NOTICE:** To prevent damage to plastic or fiberglass panels, hand start screws to ensure correct alignment.

### REAR FENDER FINISH MOLDING

#### ↔ Remove or Disconnect (Figure 15)

1. Two push-pull retainers (35)

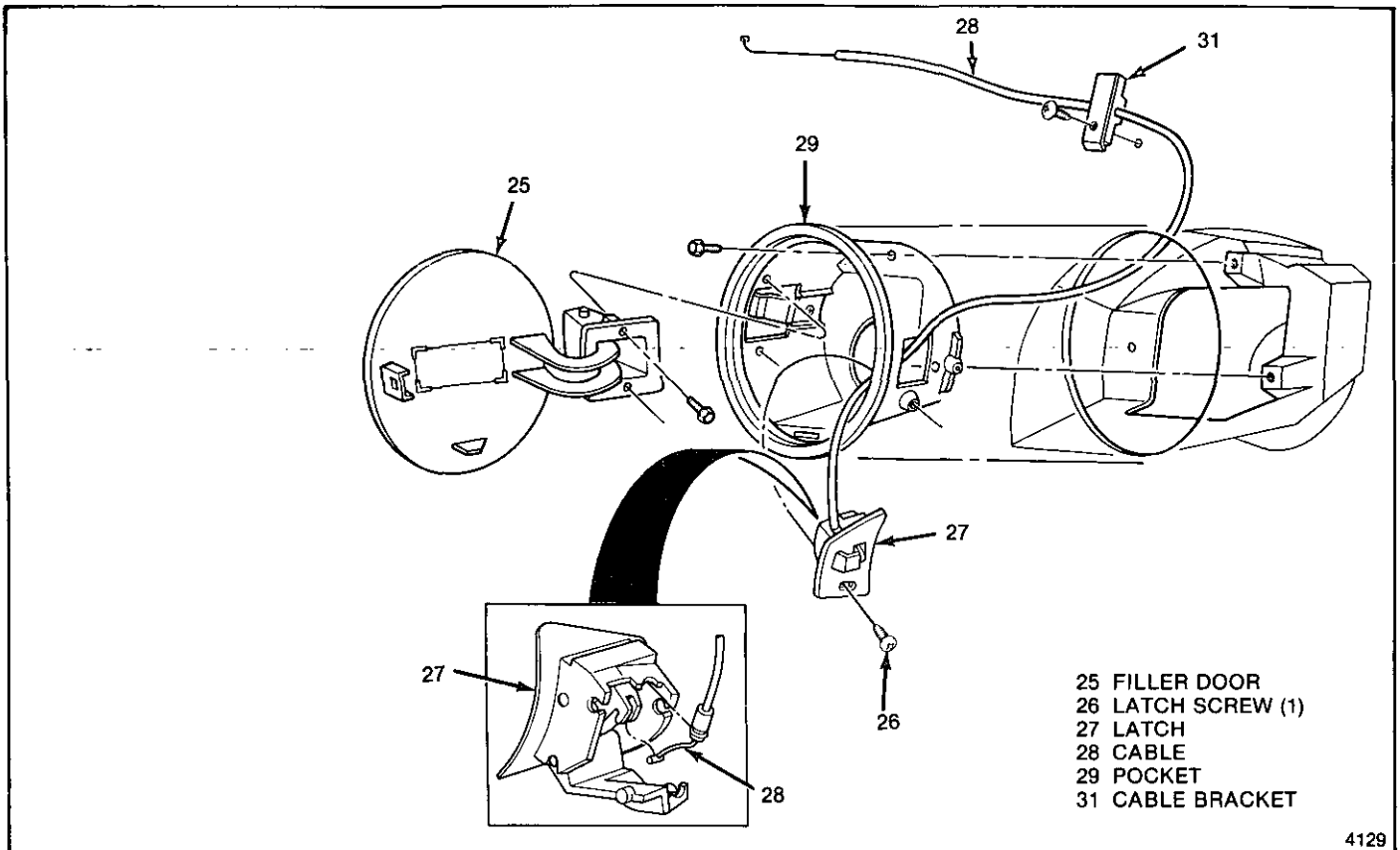

4129

Fig. 12-Locking Fuel Door and Pocket Assembly

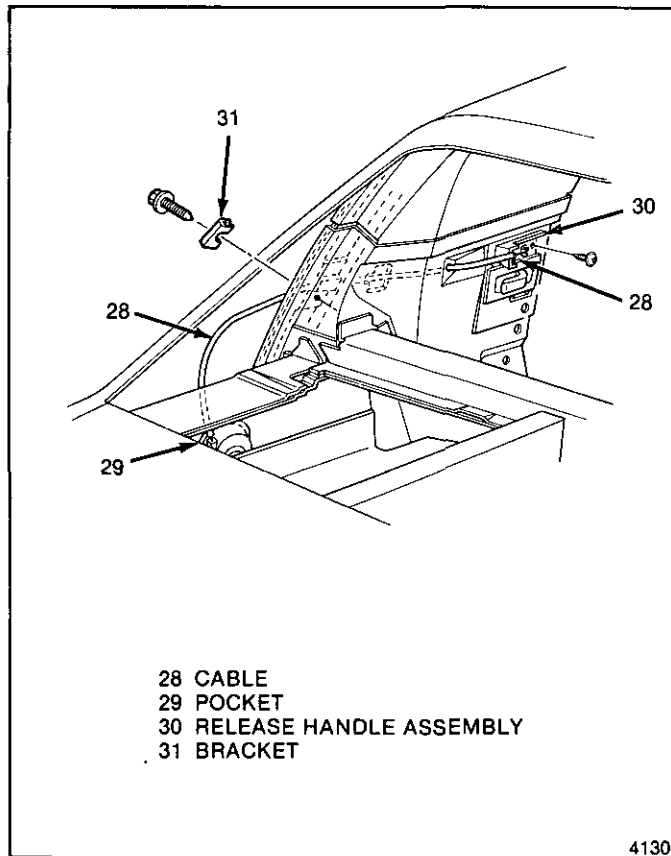

4130

Fig. 13-Fuel Filler Door Remote Latch and Cable Assembly

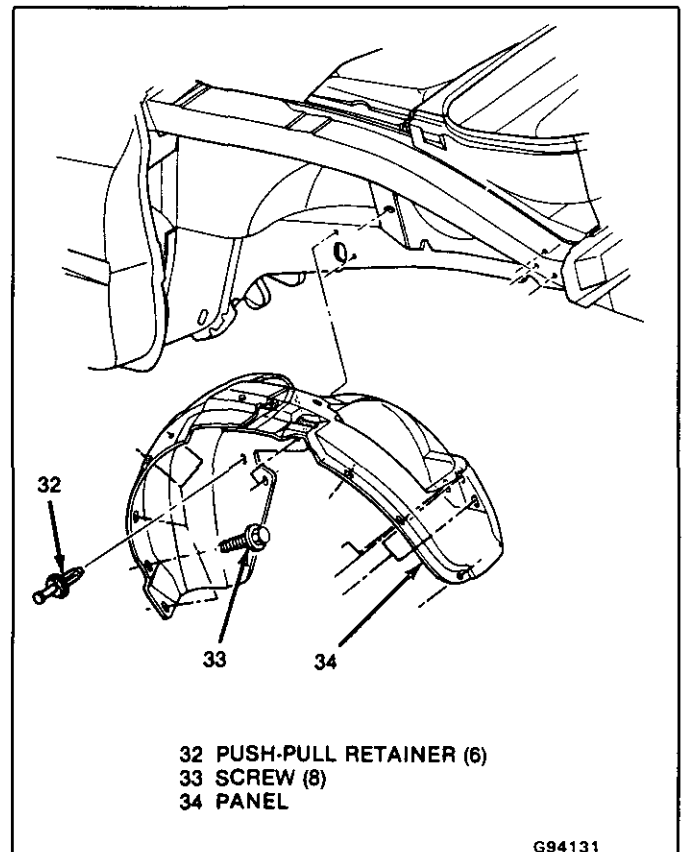

G94131

Fig. 14-Installing Rear Wheelhouse Panel

2. T clip (36)

**! Important**

To avoid damage on plastic and fiberglass panels, carefully disengage or unseat the T clip (36) with a thin-bladed tool.

3. Rivet (37) and molding clip (38)
4. Molding (39)

**↔ Install or Connect (Figure 15)**

1. Molding clip (38) and rivet (37) to body
2. T clip (36) to molding (39)
3. Molding (39)
4. Two push-pull retainers (35)

**REAR FENDER PANEL ASSEMBLY**

**↔ Remove or Disconnect (Figure 16)**

1. Rocker panel cover
2. Rear fender finish molding
3. Seven rivets (40)
4. Fender to wheelhouse panel screws (41)
5. Fender panel (42)
6. U nuts (43)
7. Seal strip (44) from fender panel

**↔ Install or Connect (Figure 16)**

1. Apply adhesive to seal strip and fender mounting surface (45) before installation.

2. Seal strip (44) to fender panel
3. U nuts (43) to fender panel (42)
4. Fender panel (42)
5. Fender to wheelhouse panel screws (41)
6. Seven rivets (40)

**NOTICE:** Care must be taken when fasteners are installed to plastic or fiberglass components. To prevent damage, align all parts before installation of fasteners.

7. Rear fender finish molding
8. Rocker panel cover

**REAR ROOF PANEL ASSEMBLY**

It is not necessary to remove rear quarter windows when removing rear roof panel assembly.

**↔ Remove or Disconnect (Figure 17)**

1. Rear compartment lid and weatherstrip. Refer to Section 7.
2. Rear compartment side cover panels
3. Rear compartment cover extensions
4. Back window side filler panels
5. Four rear roof panel to upper frame side rail bolts (46)
6. Tail lamp assemblies. Refer to Section 7.
7. Six rear roof panel to frame bolts (47)
8. Rear fender finish moldings.
9. Loosen upper portion of fender from top.

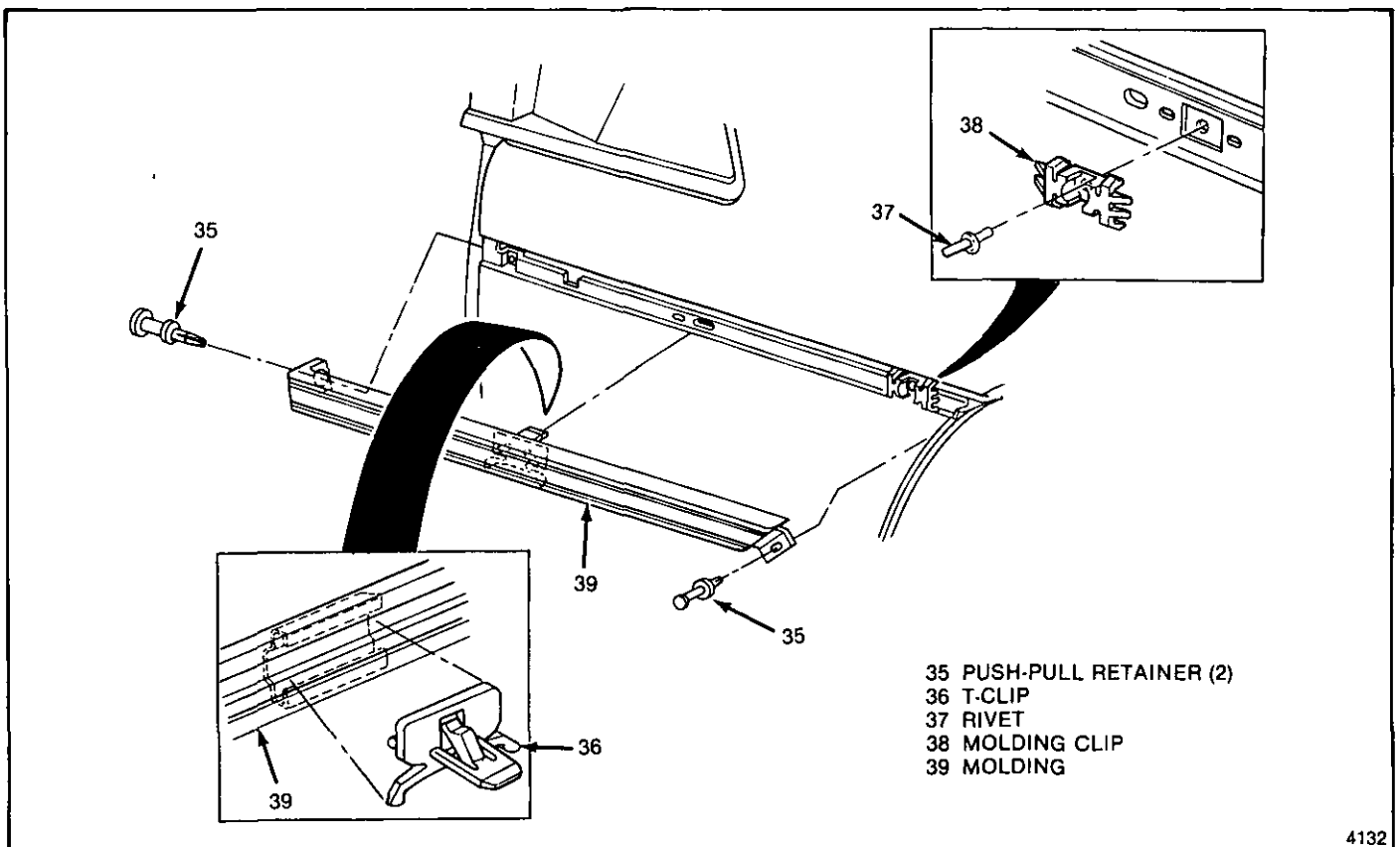

Fig. 15-Rear Fender Finish Molding

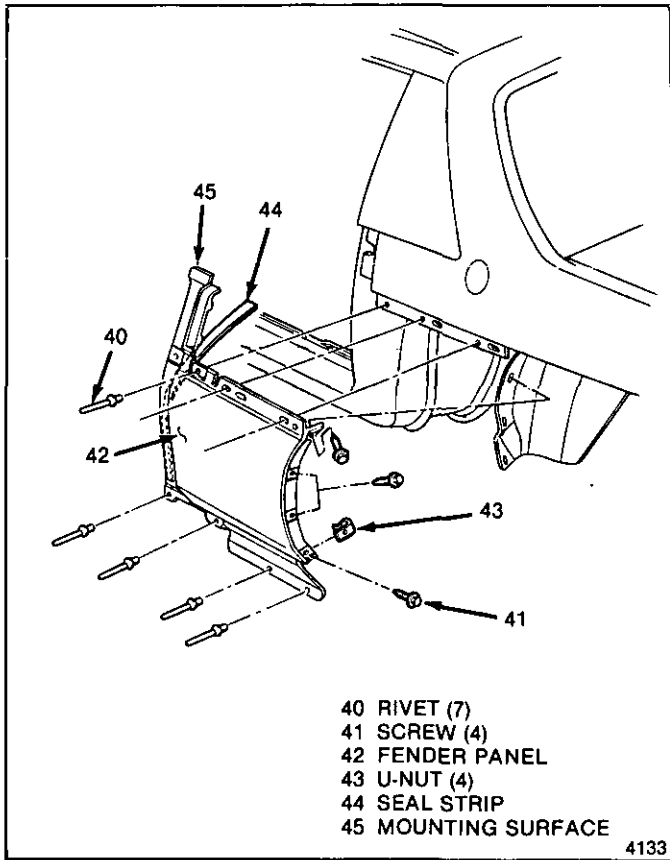

Fig.16-Rear Fender Panel Assembly

10. Rear wheelhouse to rear roof panel retainers
11. Rear markers and loosen upper portion of rear fascia from top. Refer to Section 7.
12. Fuel filler door and pocket assembly
13. Three bolts (48) inside fuel filler pocket opening
14. Upper seat belt anchor assemblies and rear quarter trim panels
15. Applique panel assemblies
16. Two rear roof panel to body side pillar bolts (49)
17. Upper garnish molding. Refer to Section 8.
18. Headlining assembly. Refer to Section 8.
19. Roof drip molding
20. Three rear roof panel to rear roof nuts (50)

21. Eight front roof panel to front roof nuts and bolts (51)

**NOTICE:** Carefully position supports to distribute pressure equally on front roof panel. Stress on roof panel can cause damage to the panel.

22. Prop up rear of front roof panel with supports.
23. Rear roof panel (52)

**→← Install or Connect (Figure 17)**

1. Rear roof panel (52). Align rear roof panel to rear roof fastener holes.
2. Eight front roof panel to front roof nuts and bolts (51)

**⌚ Tighten**

- Front roof panel fasteners to 10 N·m (7.4 ft-lb)
3. Three rear roof panel to rear roof nuts (50)

**⌚ Tighten**

- Rear roof panel nuts to 10 N·m (7.4 ft-lb)
4. Roof drip molding
5. Headlining assembly. Refer to Section 8.
6. Upper garnish moldings. Refer to Section 8.
7. Two rear roof panel to body side pillar bolts (49)
8. Applique panel assemblies
9. Rear quarter trim panels and upper seat belt anchor assemblies.

**⌚ Tighten**

Anchor bolt from 35 to 48 N·m (26 to 35 ft-lb)

10. Three bolts inside fuel filler pocket opening (48)
11. Fuel filler door and pocket assembly
12. Upper portion of rear fascia and rear markers
13. Rear wheelhouse to rear roof panel retainers
14. Upper portion of rear fenders and finish moldings. Refer to Section 7.
15. Six rear roof panel to frame bolts (47)
16. Tail lamp assemblies. Refer to Section 7.
17. Four rear roof panel to upper frame side rail bolts (46)
18. Back window side filler panels
19. Rear compartment cover extensions
20. Rear compartment side cover panels
21. Rear compartment lid and weatherstrip. Refer to Section 7.

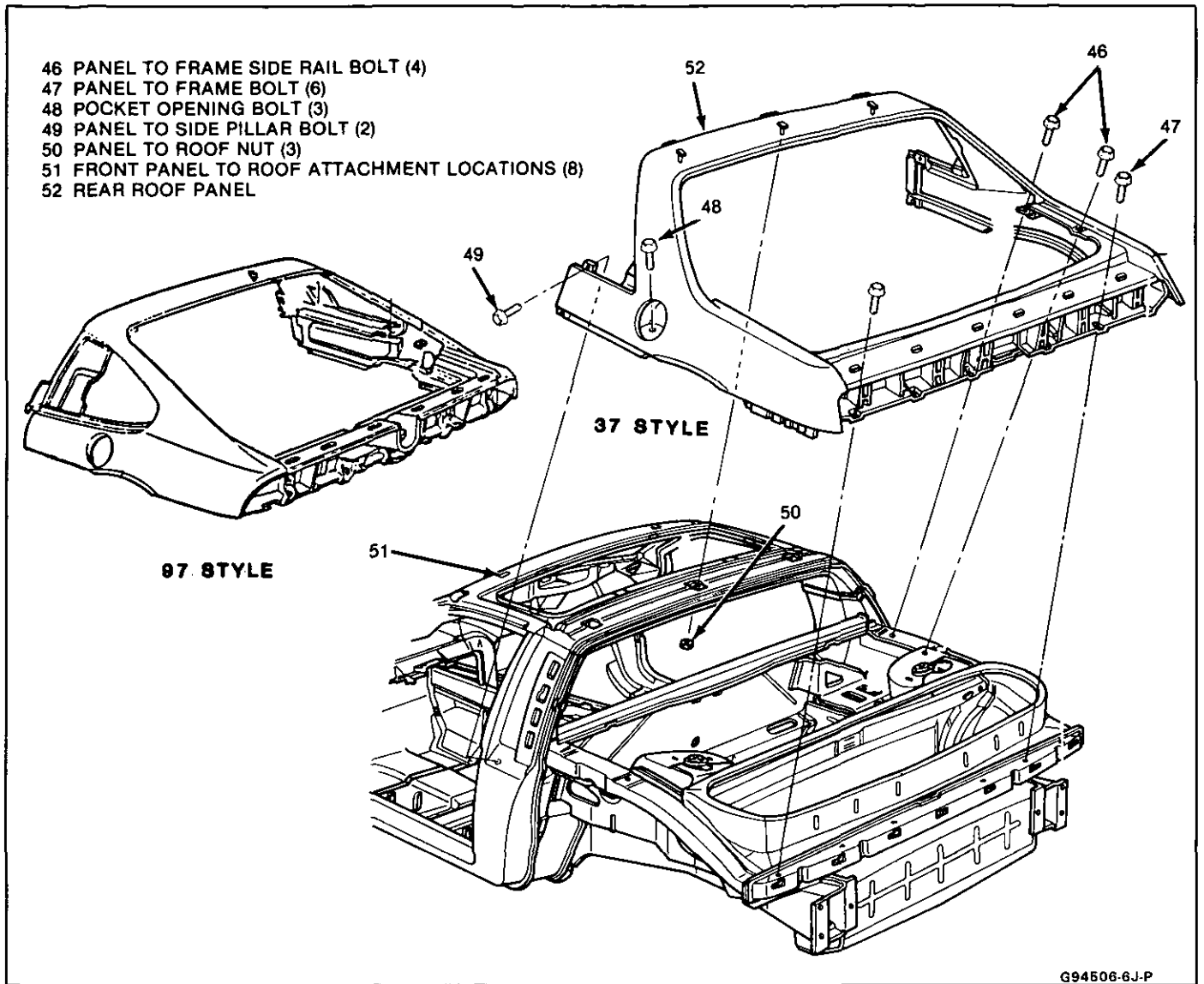

G94506-6J-P

Fig. 17-Rear Roof Panel Assembly

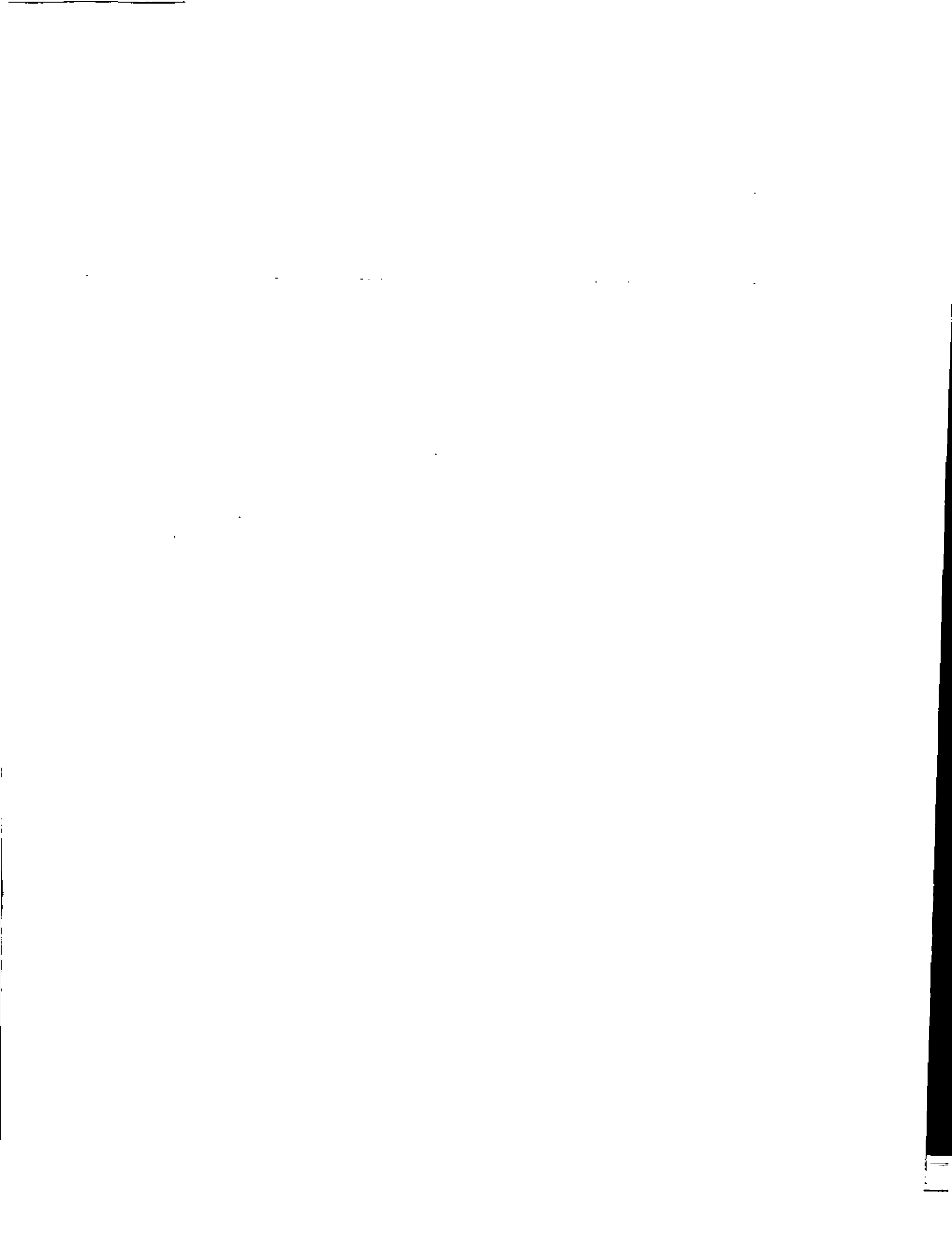



# SECTION 7

## REAR END

**NOTICE:** Care must be taken when servicing any fiberglass (SMC) panel or components. Fasteners retaining such panels or components must be hand started to prevent damage to fiberglass parts. Always use the specified torque values given for SMC parts to assure safe and proper retention.

### CONTENTS

Rear Compartment Lid .....	7-1	Rear Compartment Ajar Switch .....	7-4
Rear Compartment Hinge .....	7-1	Rear Compartment Lid Adjustment .....	7-4
Rear Compartment Torque Rods .....	7-2	Rear Compartment Weatherstrip .....	7-5
Rear Compartment Striker .....	7-2	Rear Compartment Liner .....	7-6
Rear Compartment Lid Lock Assembly .....	7-3	Tail Lamp Assembly .....	7-6
Rear Compartment Lock Cylinder .....	7-3	Luggage Carrier Assembly .....	7-8
Remote Control Deck Lid Release		Rear Fascia .....	7-8
Solenoid .....	7-4	Center High-Mounted Stop Lamp .....	7-8

### REAR COMPARTMENT LID

 Remove or Disconnect (Figure 1)

 Important

Before removing lid, mark position by scribing around hinge on lid for correct reinstallation alignment.

**CAUTION:** Torque rod bolts are under tension. Follow steps under rear compartment hinge removal and reinstallation when removing these bolts as personal injury or damage to the vehicle could result.

1. Electrical connector - remote control deck lid release at left hinge (if equipped).
2. Bolts (1)
3. Lid

 Install or Connect (Figure 1)

1. Lid, align with scribe marks
2. Screws (1)
3. Electrical connector

 Inspect

Close lid carefully and check for proper alignment.

### REAR COMPARTMENT HINGE

 Remove or Disconnect (Figure 2)

**Tools Required:**

- 2 - 12" x 12" x 1/2" plywood boards
- 2 - 1-3/8" x 1-3/8" x 4" wood blocks
- 1 - 1" inside diameter pipe 18 long

**CAUTION:** To prevent possible personal injury or damage to the vehicle, tape plywood board to rear glass above hinge area (Fig. 6). Also, install wood blocks between hinge and torque rod as shown in Figure 4 when opening lid.

**NOTICE:** Cover rear portion of rear roof panel with fender cover to prevent damage to body finish.

1. Rear compartment lid
2. Rear compartment side cover panels
3. Carburetor air intake duct (for left hinge)
4. Screw (2, Fig. 1) using tool J-35808 or equivalent
5. Nuts (5, Fig. 1)
  - Place pipe over end of torque rod (Fig. 5)
  - Remove top nut (Fig. 5)
  - Hold tension on rod with pipe (Fig. 5) while removing wood block and lower nut.
6. Hinge (4) - allow torque rod to rotate forward and rest against plywood.

 Install or Connect (Figure 2)

1. Hinge (4) - place pipe over rod and hold tension on rod (Fig. 5) while installing hinge.
2. Nuts (5)
3. Wood block between hinge and rod. With block in place, remove pipe.
4. Screw (2, Fig. 1) using tool J-35808 or equivalent
5. Carburetor air intake duct
6. Rear compartment side panels
7. Rear compartment lid
8. Partially lower lid and remove wood blocks

 Inspect

For proper alignment of rear compartment lid.

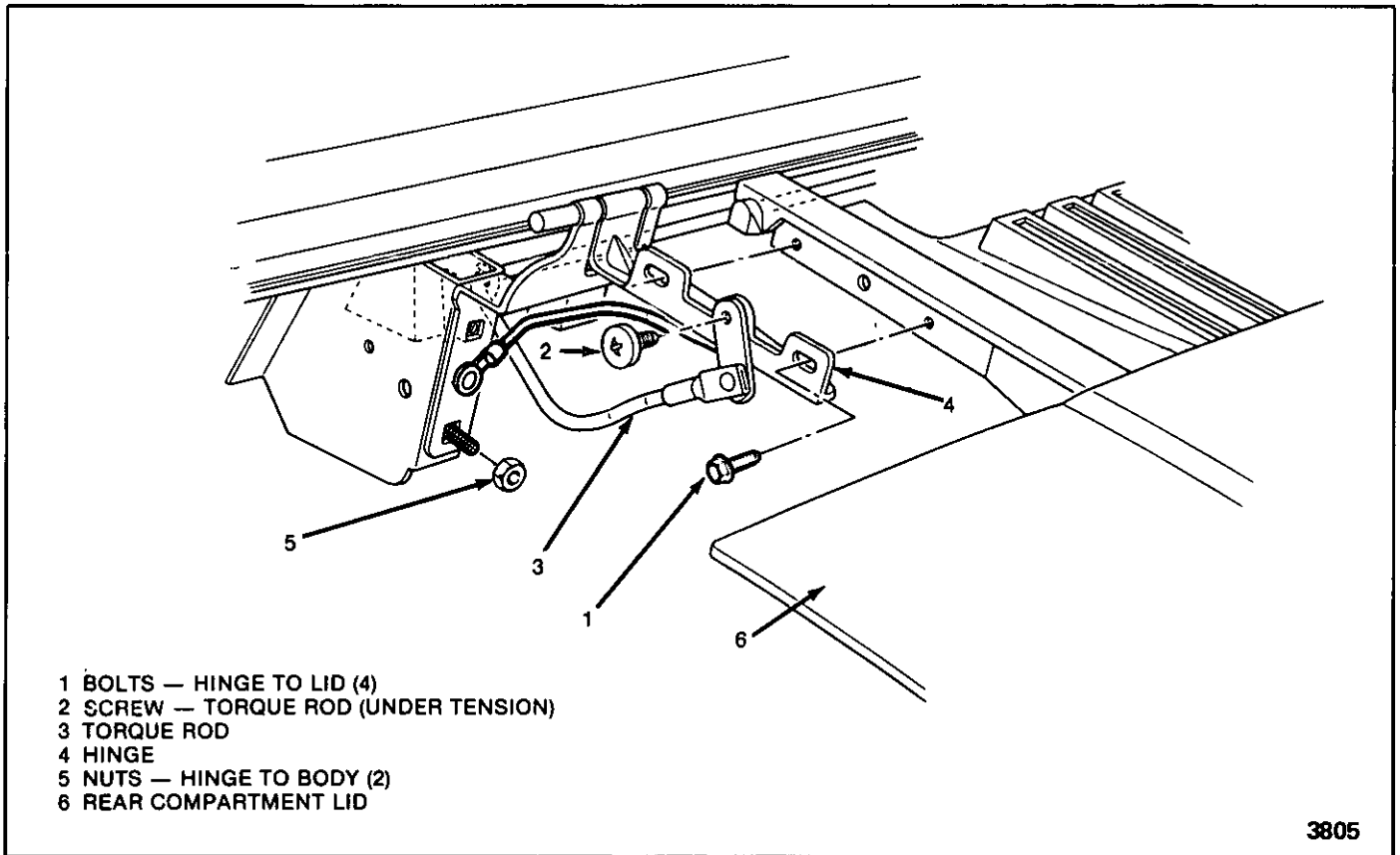

Fig. 1-Rear Compartment Lid Attachment

3805

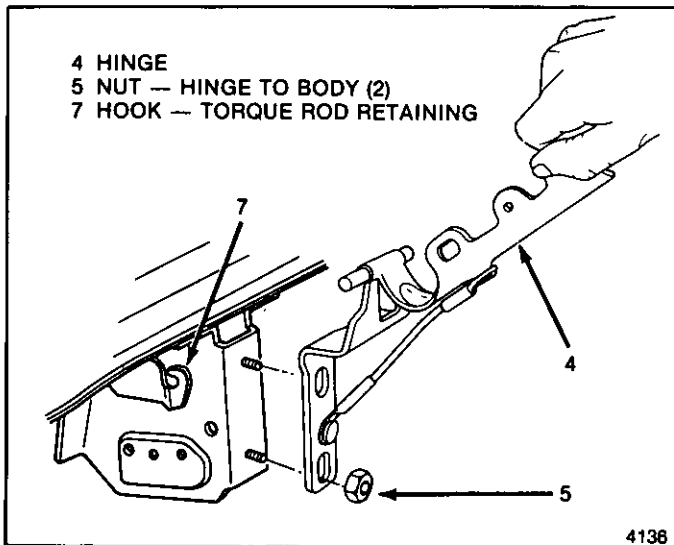

Fig. 2-Rear Compartment Lid Hinge

**REAR COMPARTMENT TORQUE RODS**

**←→ Remove or Disconnect (Figures 3, and 6)**

1. Hinge (4, Fig. 2)
2. Screw (13)
3. Pin (9) — with end of torque rod resting against plywood, grasp U end of rod (8) and pull rearward to release pin.

**↔ Install or Connect (Figures 3 and 6)**

1. Rod (3)
2. Rod (3) in hook (7)
3. Pin (9)
  - With torque rod resting against plywood, grasp U end of rod (8) and pull rearward to insert pin.
  - Release U end (8) of rod and be sure that end of rod hooks over pin.
4. Screw (13)
5. Hinge (4, Fig. 2)

**🔑 Adjust**

To increase tension on torque rod, move the pin (9) rearward one hole.

**REAR COMPARTMENT STRIKER**

**←→ Remove or Disconnect (Figure 7)**

1. Bolts (16)
2. Striker (15)

**↔ Install or Connect (Figure 7)**

1. Striker (15)

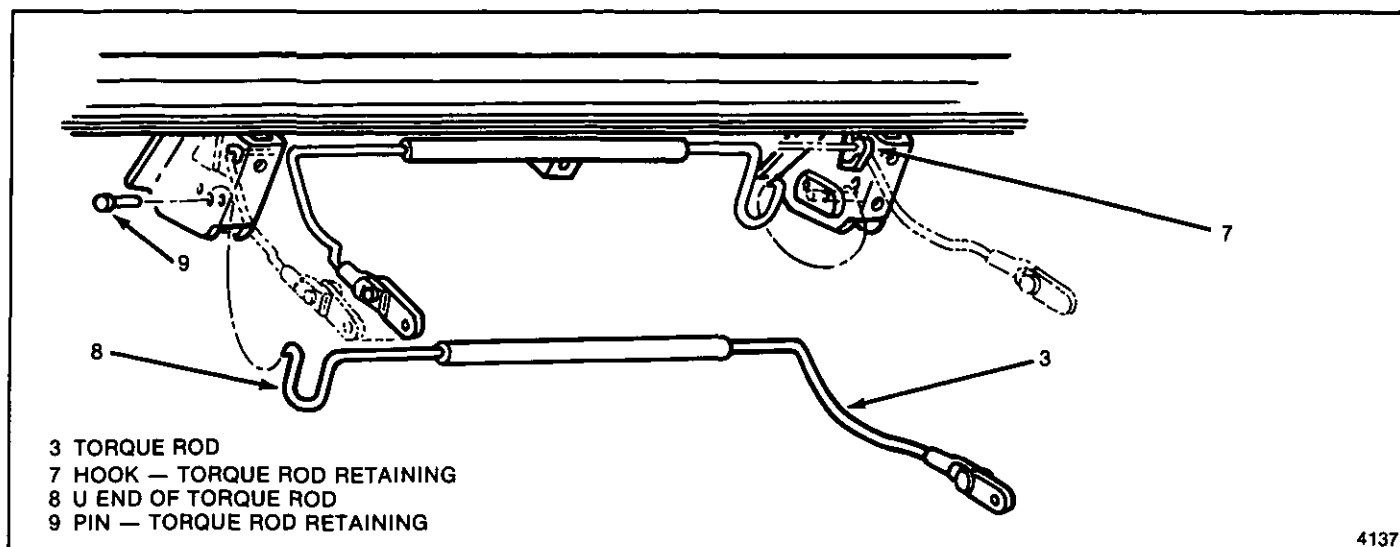

Fig. 3-Rear Compartment Lid Torque Rod

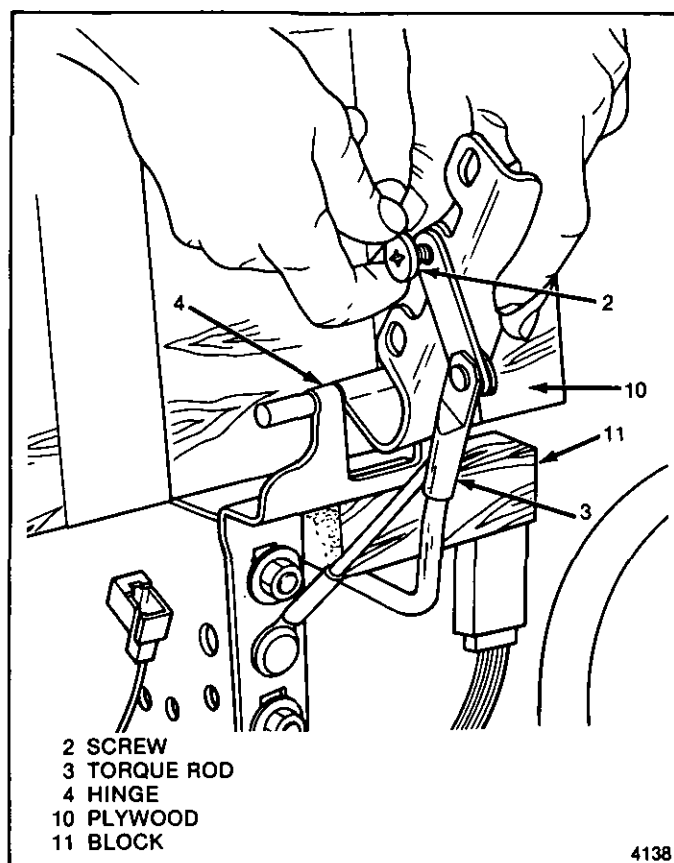

Fig. 4-Attaching Rear Compartment Lid Torque Rod

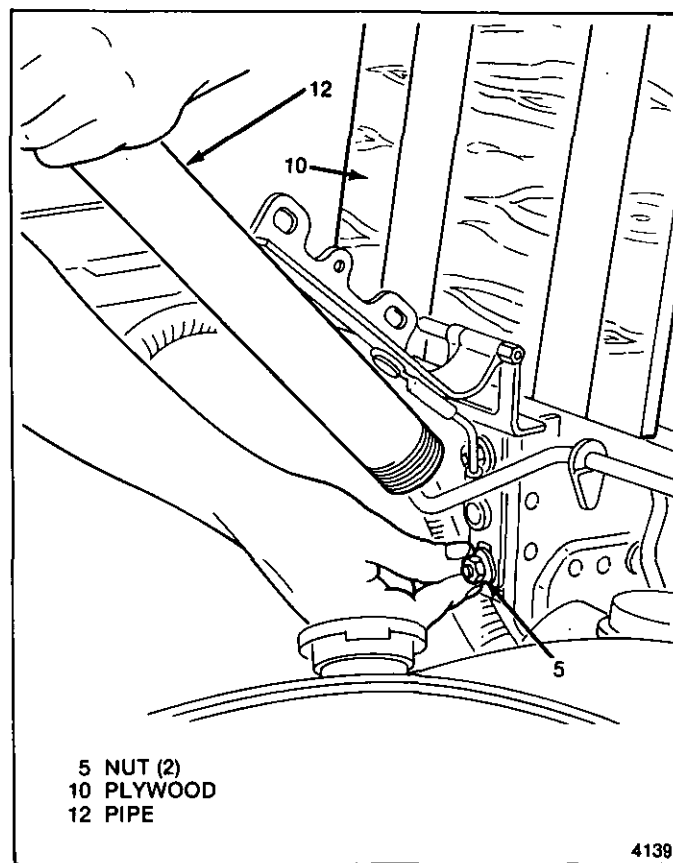

Fig. 5-Installing Rear Compartment Lid Hinge

### REAR COMPARTMENT LID LOCK ASSEMBLY

↔ Remove or Disconnect (Figure 8)

1. Bolts (18)
2. Lock Assembly (17)

→← Install or Connect (Figure 8)

1. Lock assembly (17)
2. Bolts (18)

### REAR COMPARTMENT LOCK CYLINDER

37 Style

↔ Remove or Disconnect (Figure 9)

1. Screw (22)
2. Retainer (21)
3. Cylinder (19) and gasket (20)

→← Install or Connect (Figure 9)

1. Cylinder (19) and gasket (20)

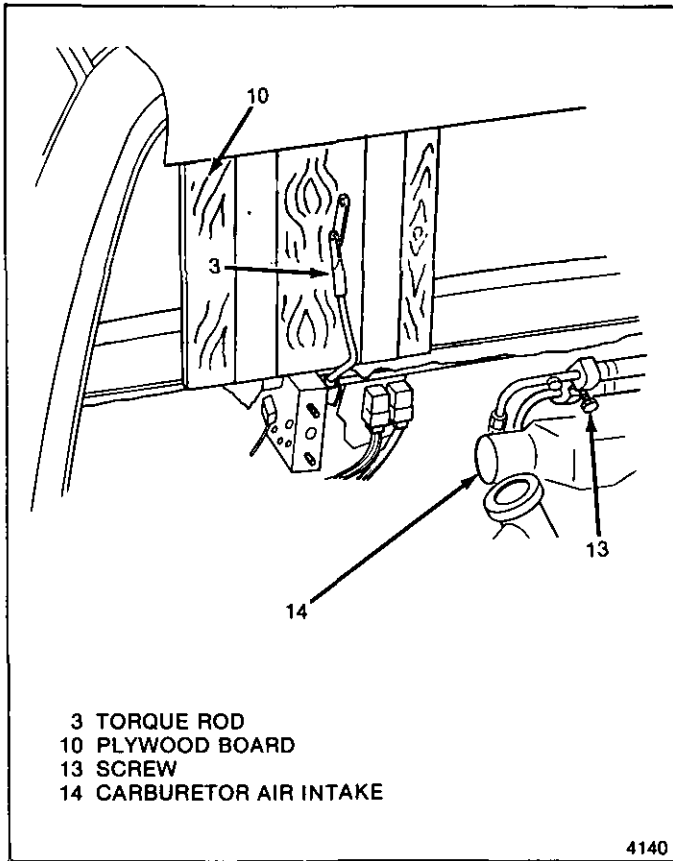

Fig. 6-Rear Compartment Lid Torque Rod Detached

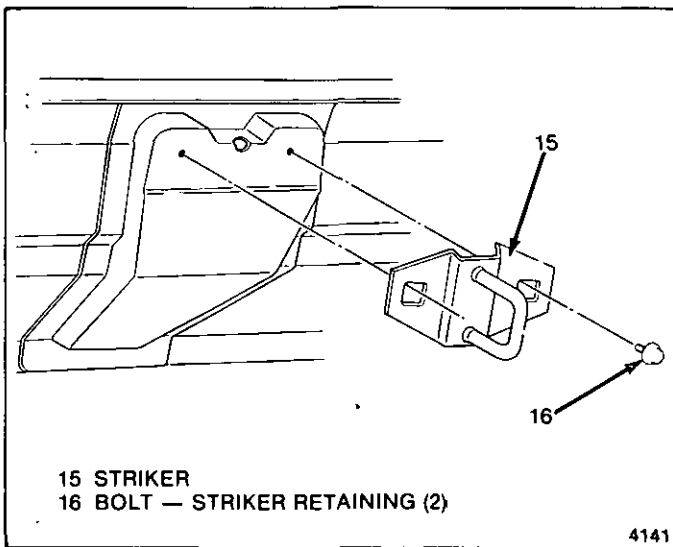

Fig. 7-Rear Compartment Lid Striker

↔ Install or Connect

1. Lock cylinder (19A) to support (23A)
2. Retainer (21A)
3. Cover (20A)
4. Screws (22A)

**REMOTE CONTROL DECK LID RELEASE SOLENOID**

↔ Remove or Disconnect (Figure 11)

1. Screw (24)
2. Electrical connector
3. Solenoid (23). Slide solenoid from latch to disengage tab.

↔ Install or Connect (Figure 11)

1. Solenoid (23). Engage tab on latch.
2. Screw (24)
3. Electrical connector

**REAR COMPARTMENT AJAR SWITCH**

The rear compartment ajar switch is located at the top left corner of the stowage compartment. This switch indicates if the rear compartment lid is not fully closed by sending electrical current to an indicator light located in the instrument panel.

↔ Remove or Disconnect

1. Pull up on switch to disengage switch from body
2. Electrical connector from switch

↔ Install or Connect

1. Electrical connector to switch
2. Switch to body

**REAR COMPARTMENT LID ADJUSTMENT**

The following adjustment procedures identify rear compartment lid misalignment conditions. More than one condition may be present. Perform adjustments only as required for correct alignment and operation.

🔑 Adjust (Figures 1 and 7)

- Trailing edge too high or low
  - Loosen bolts (16)
  - Raise or lower striker (15) as required
  - Tighten bolts (16)
- Lock assembly binding on side of striker
  - Loosen bolts (16)
  - Move striker (15) left or right as required
  - Tighten bolts (16)
- Leading edge too high or low (either side)
  - Loosen nuts (5)
  - Raise or lower hinge (4) as required
  - Tighten nuts (5)

2. Retainer (21)
3. Screw (22)

**97 Style**

↔ Remove or Disconnect (Fig. 10)

1. Screws (22A) four required
2. Cover (20A)

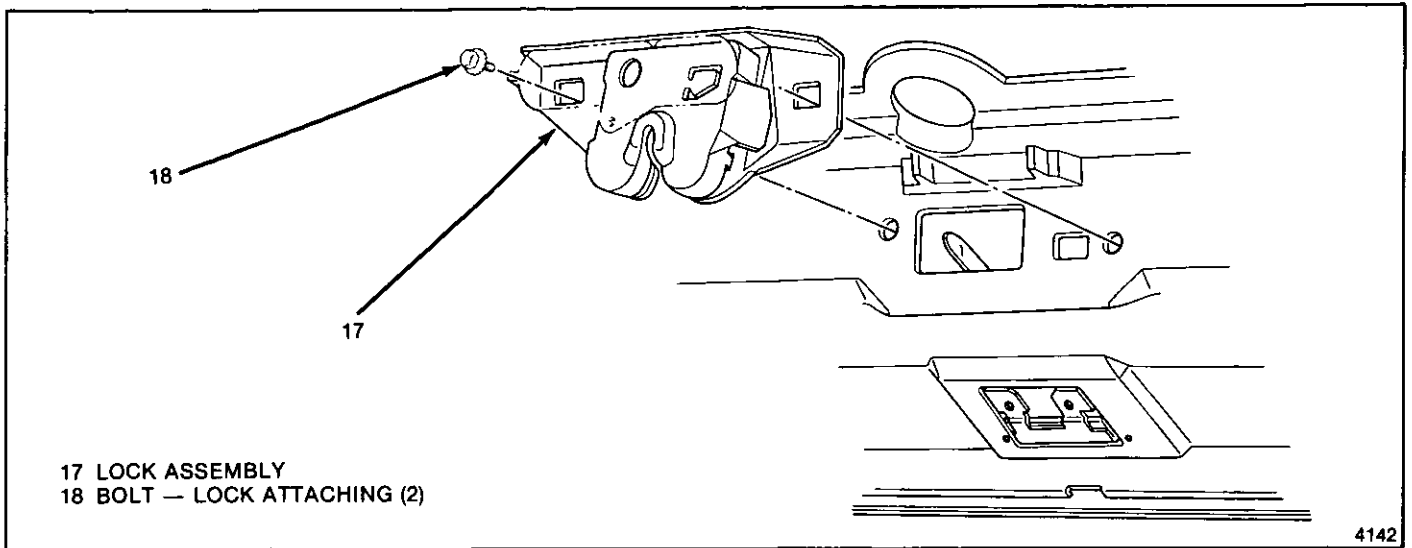

Fig. 8-Rear Compartment Lid Lock Assembly

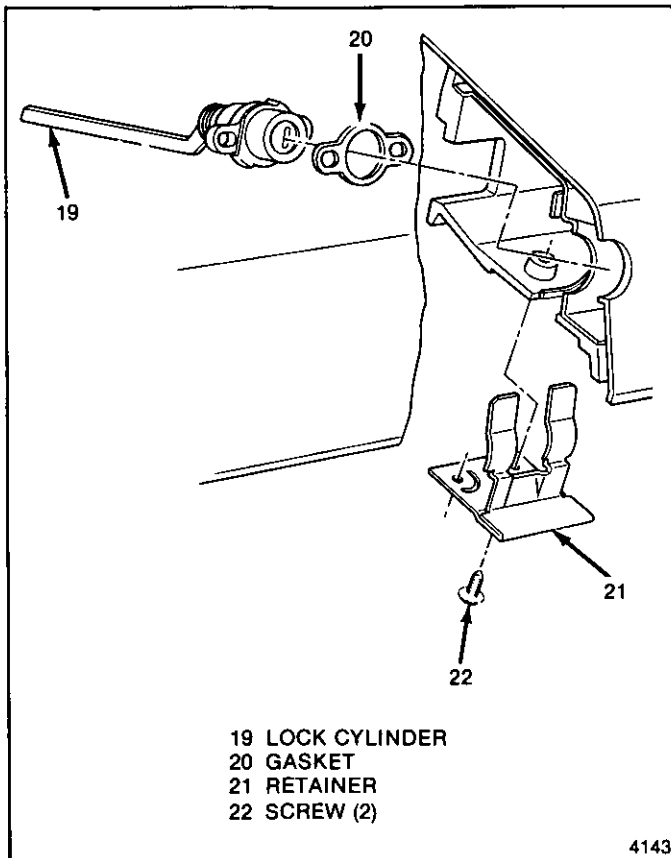

Fig. 9-Rear Compartment Lock Cylinder

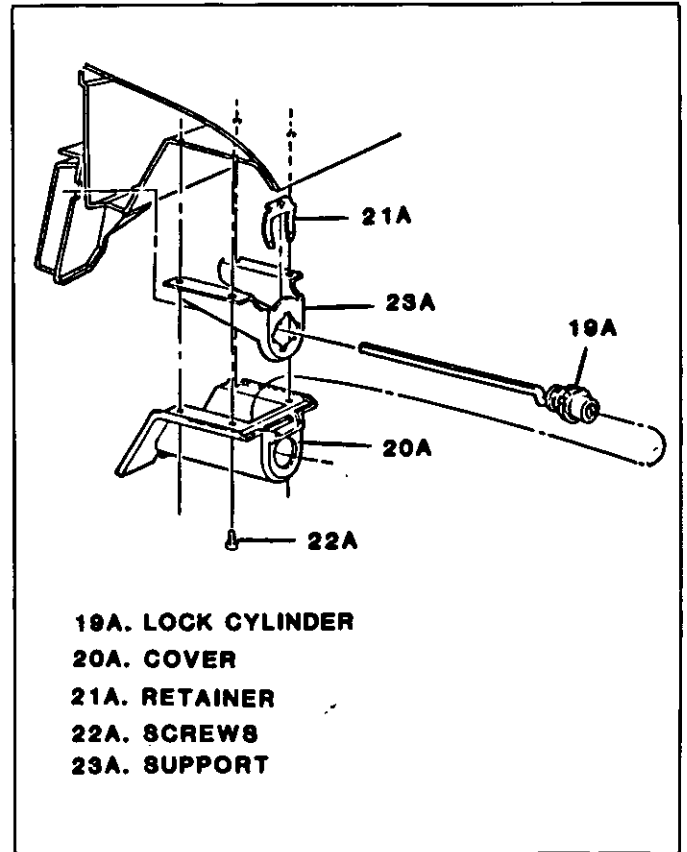

Fig. 10 - Installing Lock Cylinder - 97 Style

- Tighten nuts (5)
- Lid too far fore or aft (either side)
  - Loosen bolts (1)
  - Align lid
  - Tighten bolts (1)



**Inspect**

Lid for proper operation and alignment

### REAR COMPARTMENT WEATHERSTRIP

Remove or Disconnect (Figure 12)

Weatherstrip (28) from flange. Start at any convenient location and pull inward to remove.

Install or Connect (Figure 12)

Weatherstrip (28) on flange (29). Place slot in weatherstrip over flange and push on securely. Continue around weatherstrip being sure it is fully seated on flange.

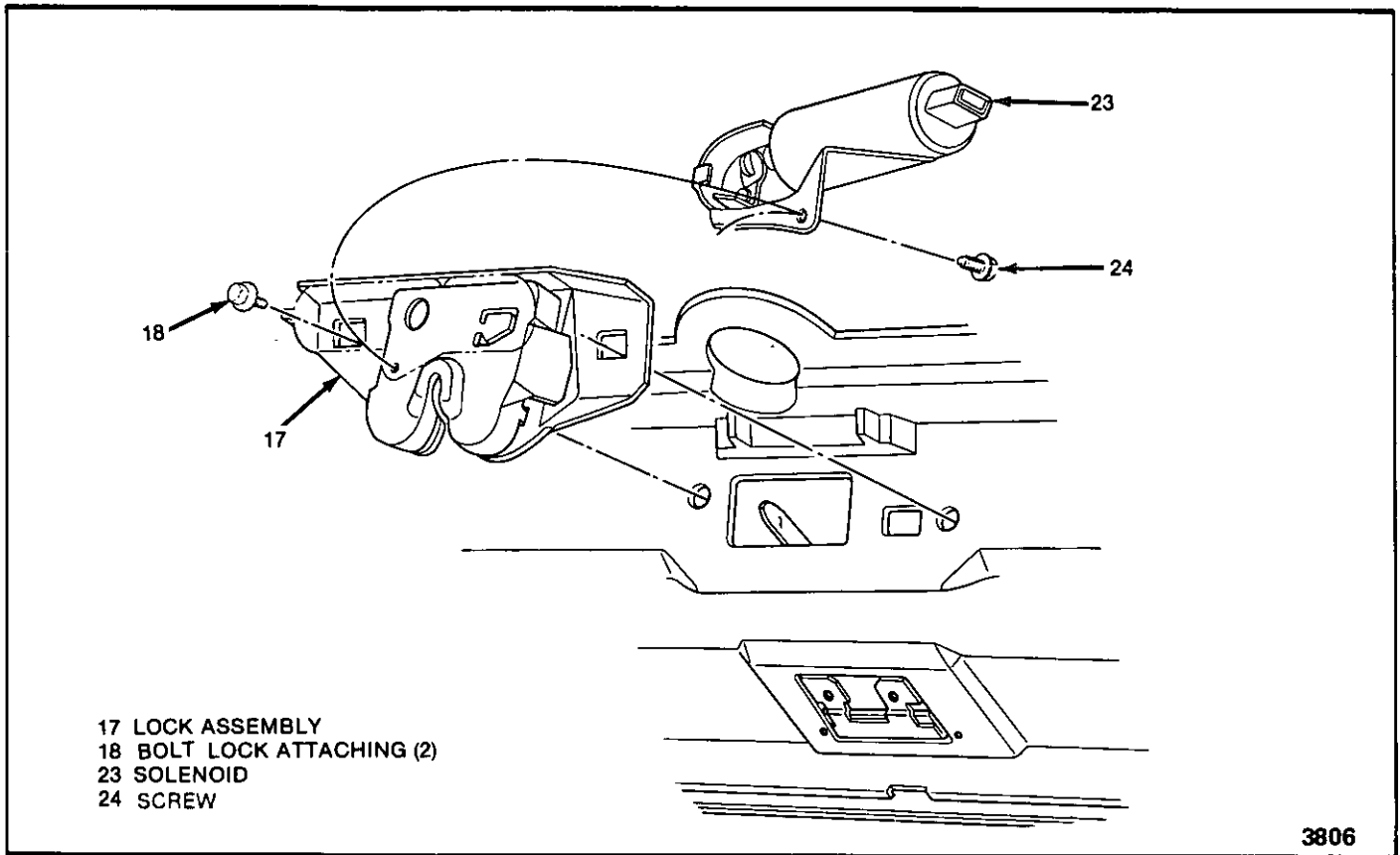

Fig. 11-Remote Control Rear Compartment Lid Release

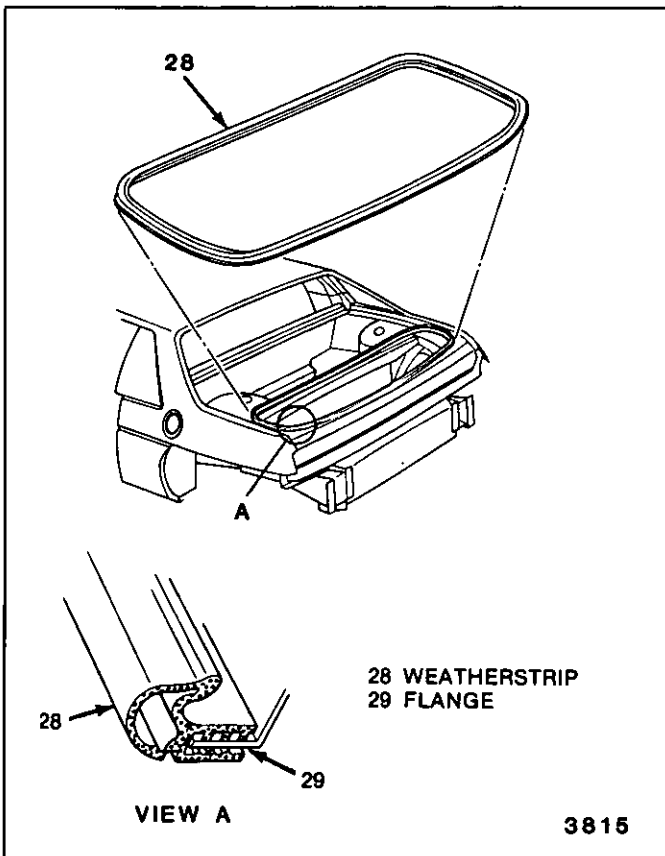

Fig. 12-Rear Compartment Weatherstrip

### REAR COMPARTMENT LINER

**↔** Remove or Disconnect (Figure 13)

1. Rear compartment weatherstrip (28)
2. Rear compartment lamp
3. Rear compartment liner (30)

**→←** Install or Connect (Figure 13)

1. Rear compartment liner (30)
2. Rear compartment lamp
3. Rear compartment weatherstrip (28)

### TAIL LAMP ASSEMBLY

**↔** Remove or Disconnect (Figure 14)

1. Covers (31)
2. Six screws (32)
3. Tail lamp assembly (33)
4. Bulb assemblies (34)

**→←** Install or Connect (Figure 14)

1. Bulb assemblies (34)
2. Tail lamp assembly (33)

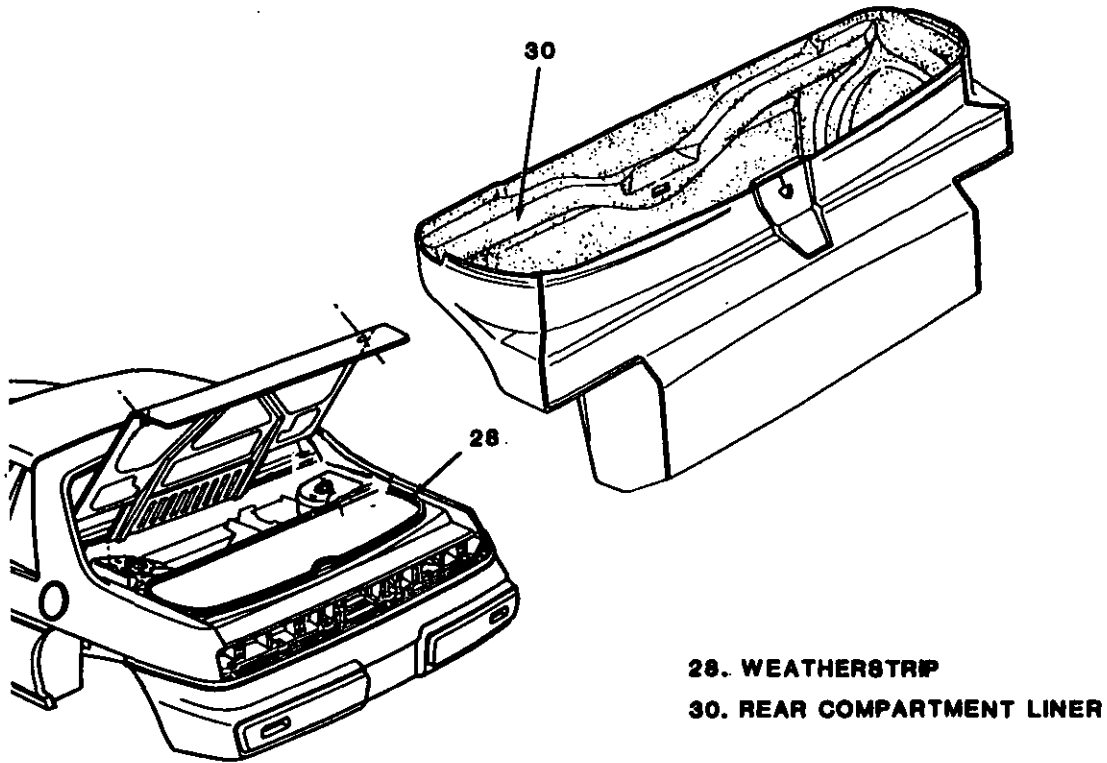

Fig. 13-Rear Compartment Liner

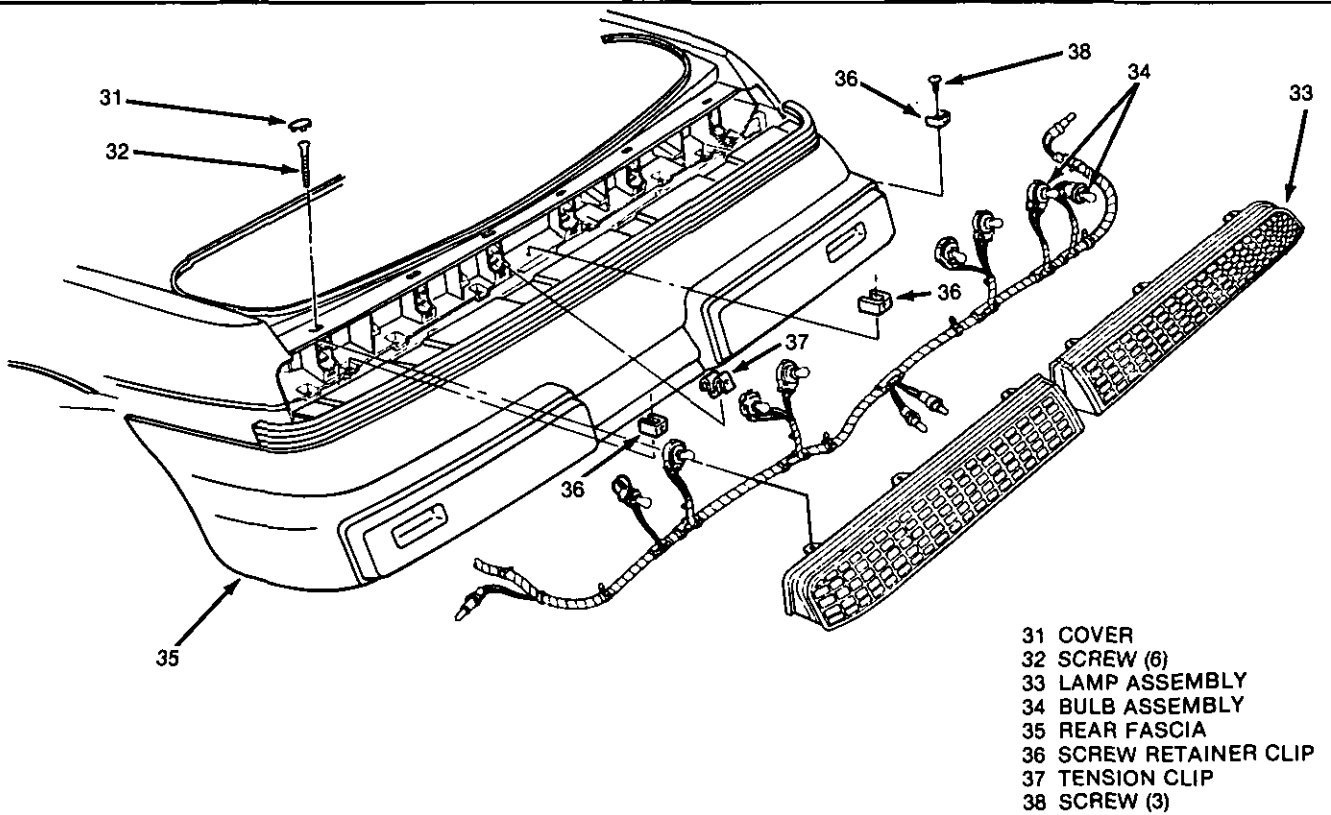

Fig. 14-Tail Lamp Assembly - 37 Style Shown, 97 Style Similar

**LUGGAGE CARRIER ASSEMBLY**

**↔ Remove or Disconnect (Figure 15)**

1. Rubber straps (39)
2. Two nuts (41)
3. Two bolts (43)
4. Eleven screws (48)
5. Bolt (42)
6. Eleven nuts (40)

**→← Install or Connect (Figure 15)**

1. Eleven nuts (40)

**🔍 Inspect**

Rubber caged nuts to ensure rubber is not cut or torn to allow proper sealing.

2. Bolt (42)
3. Eleven screws (48)
4. Two bolts (43)
5. Two nuts (41)
6. Rubber strips (39), insert both ends of strip and roll center portion to fit.

**REAR FASCIA**

**↔ Remove or Disconnect (Figure 16)**

1. Tail lamp assembly
2. Seven retainers (49)
3. Seven retainers (53)

4. Side marker lamp assemblies
5. Bolts (50)
6. Bolts (51)
7. Bolts (52)

**→← Install or Connect (Figure 16)**

1. Seven retainers (53)
2. Seven retainers (49)
3. Bolts (50)
4. Bolts (51)
5. Bolts (52)
6. Side marker lamp assemblies
7. Tail lamp assembly

**CENTER HIGH-MOUNTED STOP LAMP**

The center high-mounted stop lamp is attached to the roof at the centerline of the back window.

**↔ Remove or Disconnect (Fig. 17)**

1. Screws (54)
2. Cover (55)
3. Screws (56)
4. Connector (57)
5. Center high-mounted stop lamp (58)

**→← Install or Connect**

1. Center high-mounted stop lamp (58)
2. Connector (57)
3. Screws (56)

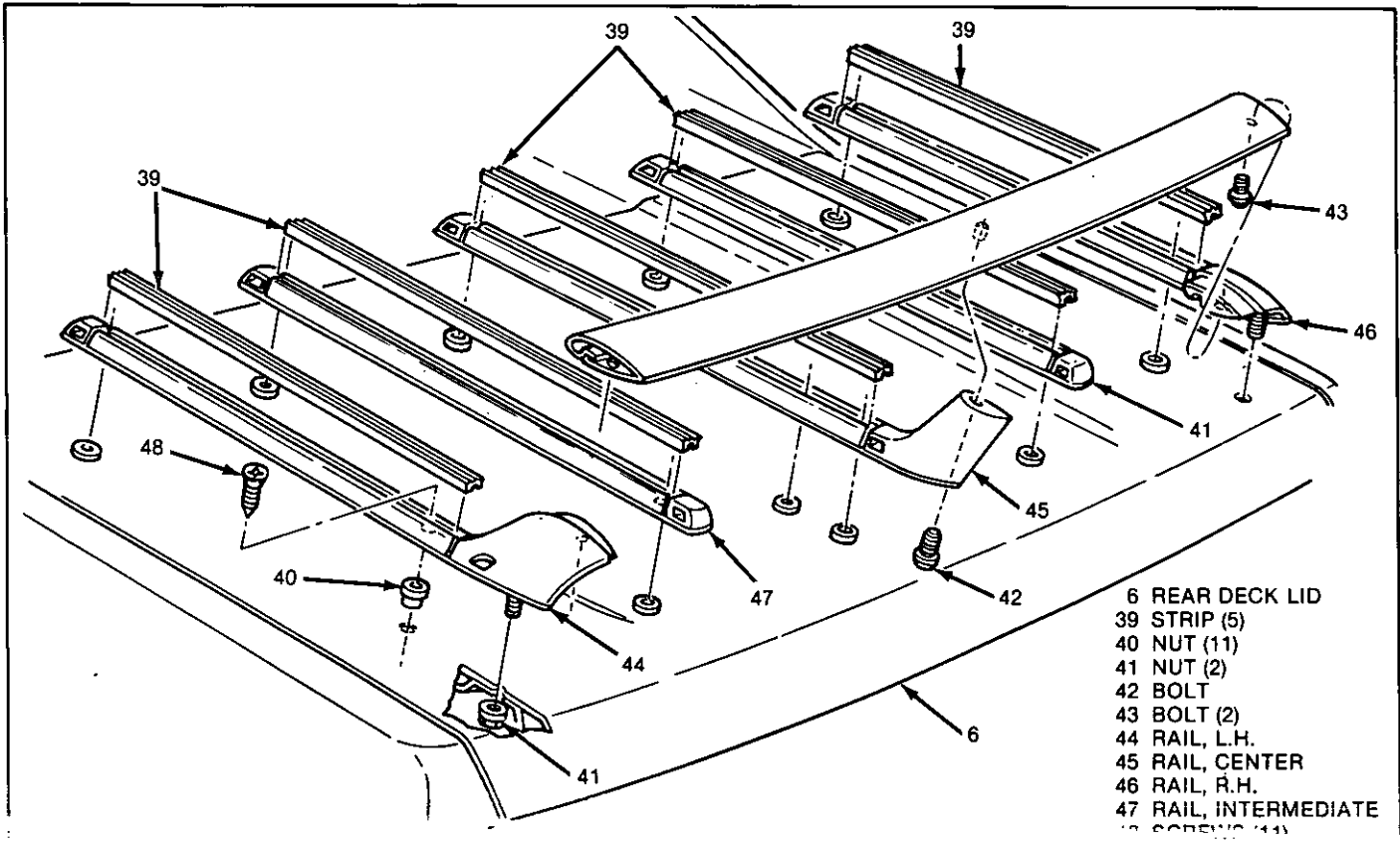



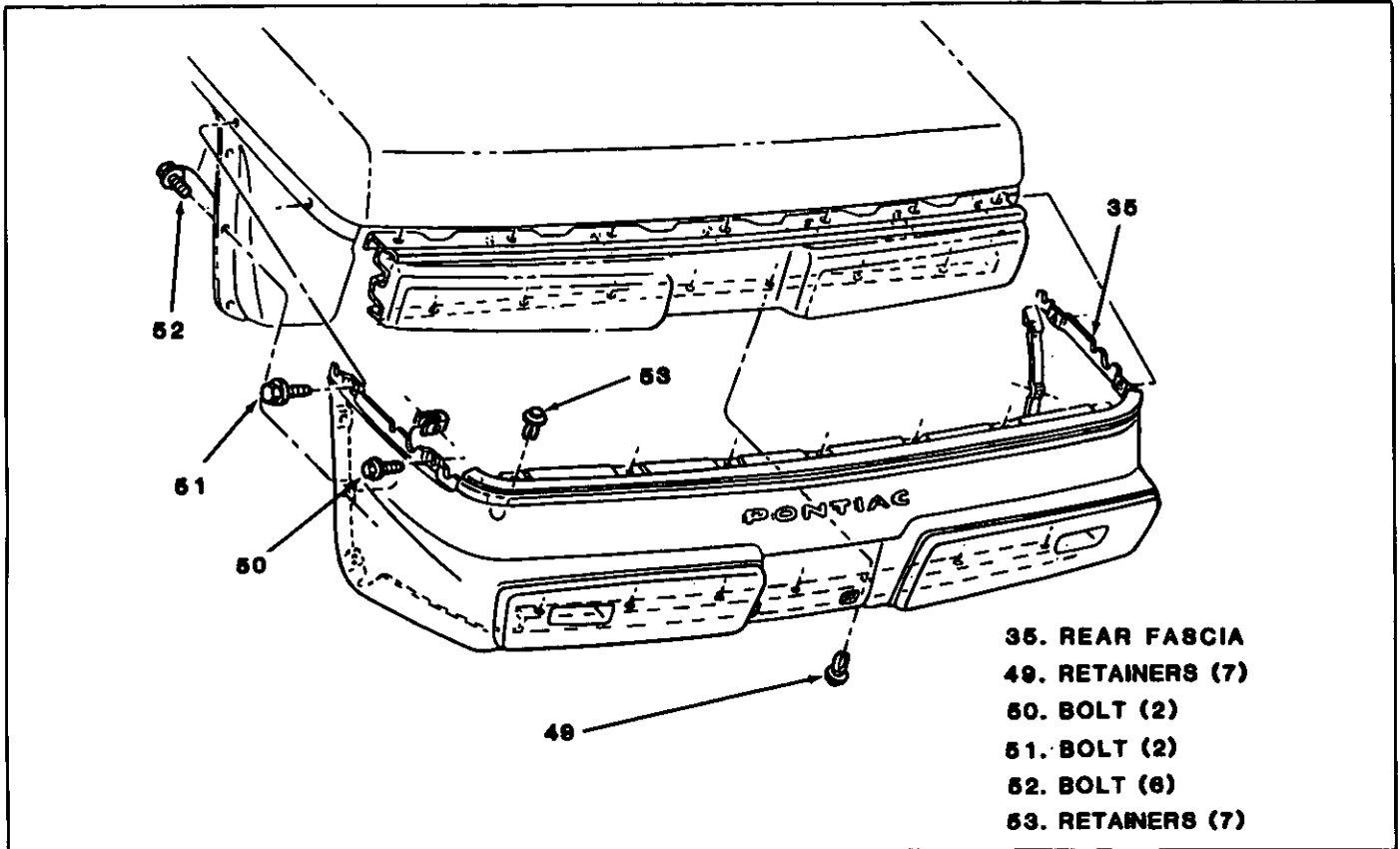

Fig. 16-Rear Fascia

- 4. Cover (55)
- 5. Screws (54)

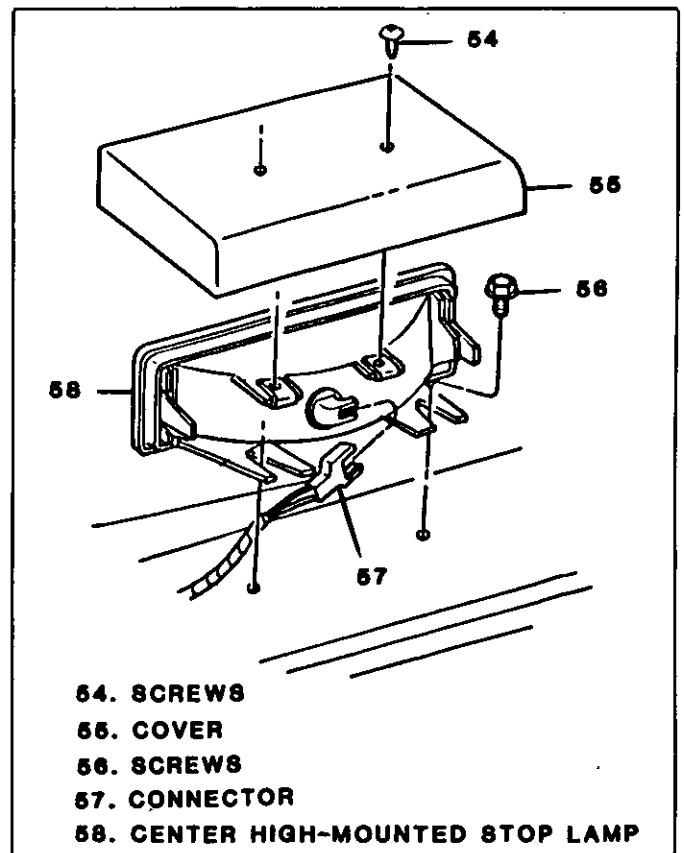
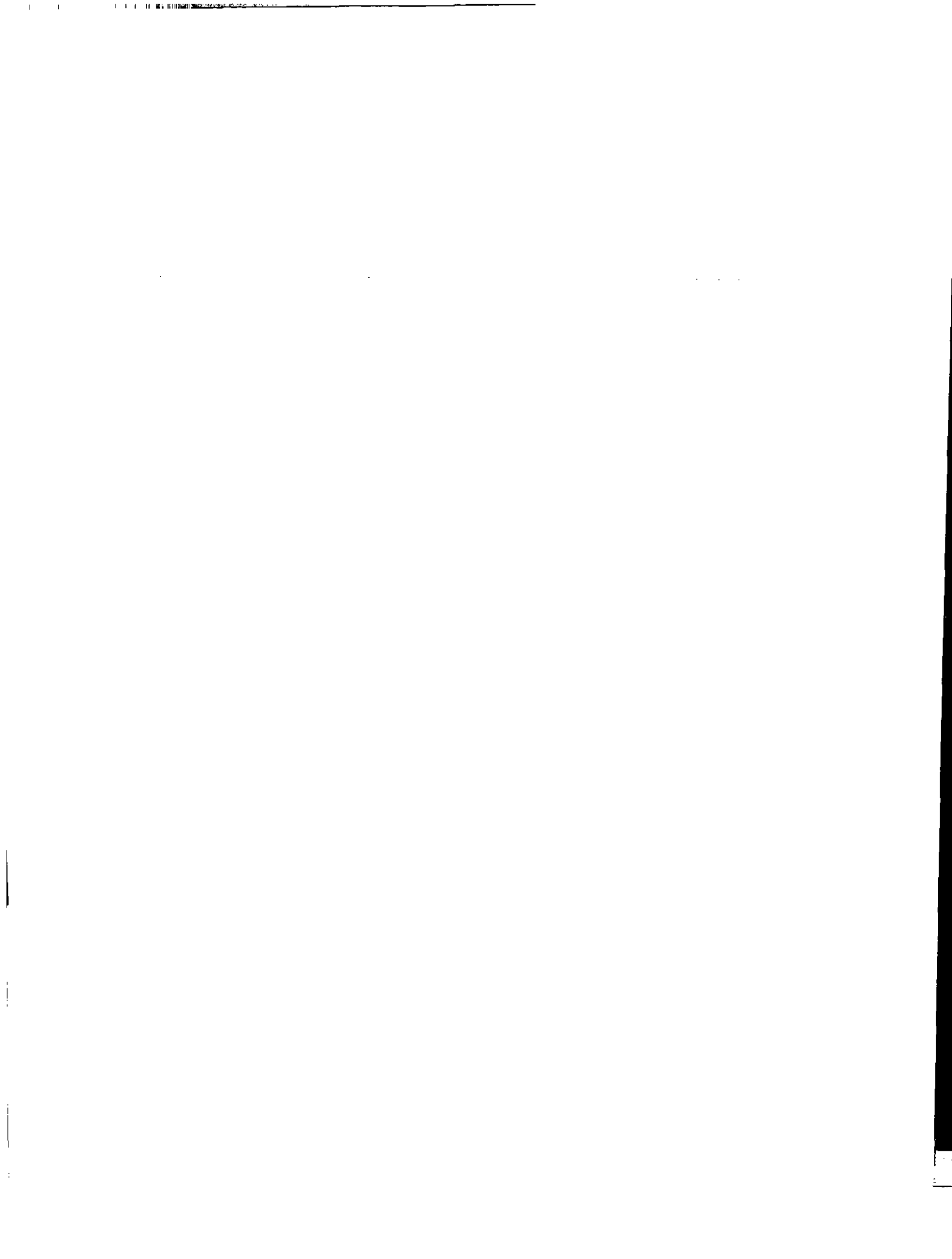

Fig. 17 - Center High-Mounted Stop Lamp



# SECTION 8

## ROOF

**NOTICE:** Care must be taken when servicing any fiberglass (SMC) panel or component. Fasteners retaining such panels or components must be hand started to prevent damage to fiberglass parts. Always use the specified torque values given for SMC parts to assure safe and proper retention.

### CONTENTS

Roof .....	8-1	Vista Vent .....	8-4
Roof Panel .....	8-1	Vista Vent Glass and Hardware .....	8-6
Formed Headlining .....	8-3	Vista Vent Headlining Retainer and	
Dome Lamp Assembly .....	8-3	Finishing Lace .....	8-6
Sunshade Assembly .....	8-4	Vent Glass Weatherstrip .....	8-6
Interior Upper Garnish Moldings .....	8-4		
Roof Drip Moldings .....	8-4		

## ROOF

### ROOF PANEL

The roof panel consists of a one piece sheet molded compound panel. It is secured to the space frame with ten screws and nuts. Sealing strips are used to seal the roof panel and prevent air or water leaks. An opening in the roof of the space frame is provided for the optional vista vent.

**↔ Remove or Disconnect (Figures 8-1, 8-2, 8-3 and 8-4)**

1. Wiper arms: Refer to Section 8E in the chassis portion.
2. Shroud top vent screen. Refer to Section 4.
3. Windshield molding assembly. Refer to Section 11.
4. Vista vent assembly (if equipped)
5. First three fender to side rail attaching bolts from windshield on right and left fenders.
  - Release fenders at top for adequate clearance with roof cover panel.
6. Roof drip moldings
7. Interior upper garnish moldings
8. Dome lamp assembly
9. Sunshade assemblies
10. Headlining assembly
11. Two roof panel attaching screws (2) at cowl panel (3)
12. Two nuts and six screws (4)
13. Roof panel (1)
14. Sealing strips and fillers — windshield frame at belt (6)

**🧼 Clean**

- All areas where sealing strips are to be applied within ten minutes of installation. Use denatured alcohol or lacquer thinner and dry immediately with a clean cloth.

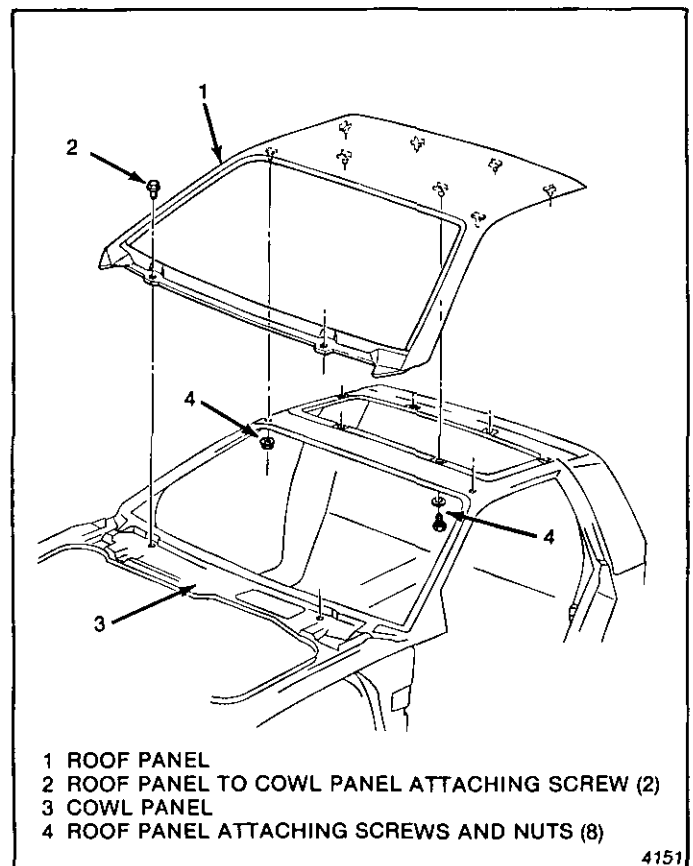
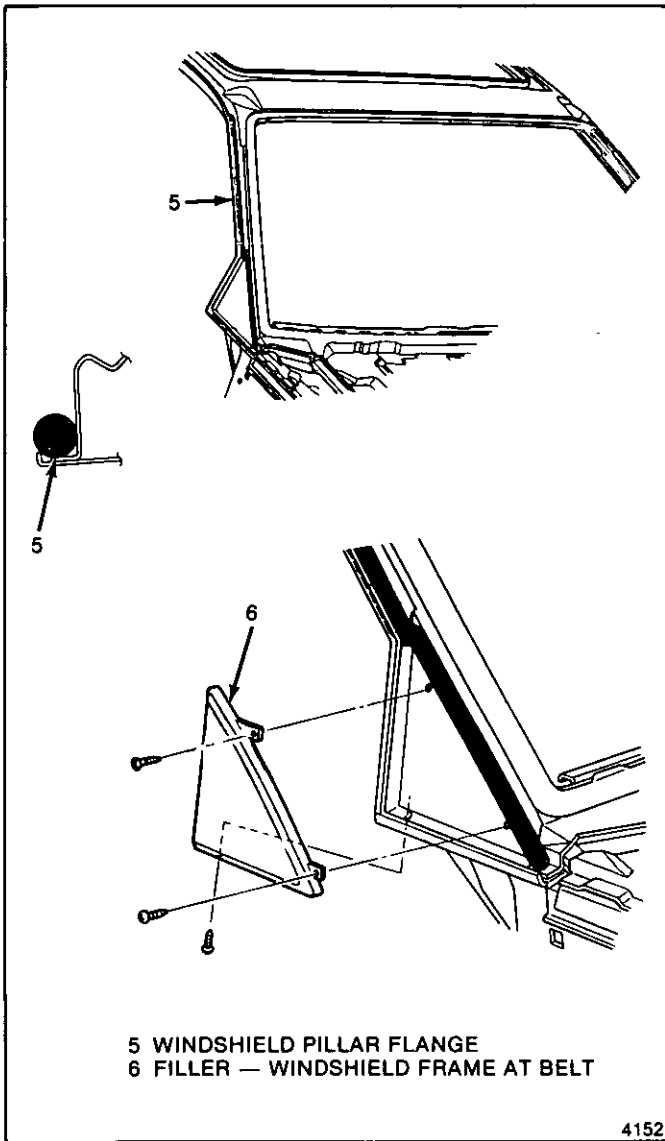

Fig. 8-1-Roof Panel Attachment

**↔ Install or Connect (Figures 8-1, 8-2, 8-3, and 8-4)**

1. Sealing strips to windshield pillar flanges (5)
  - Apply moving from bottom of pillar flange (5) toward top of roof.
2. Right and left side fillers — windshield frame at belt (6)



5 WINDSHIELD PILLAR FLANGE  
6 FILLER — WINDSHIELD FRAME AT BELT

4152

Fig. 8-2 Windshield Pillar Flange and Filler — Windshield Frame at Belt

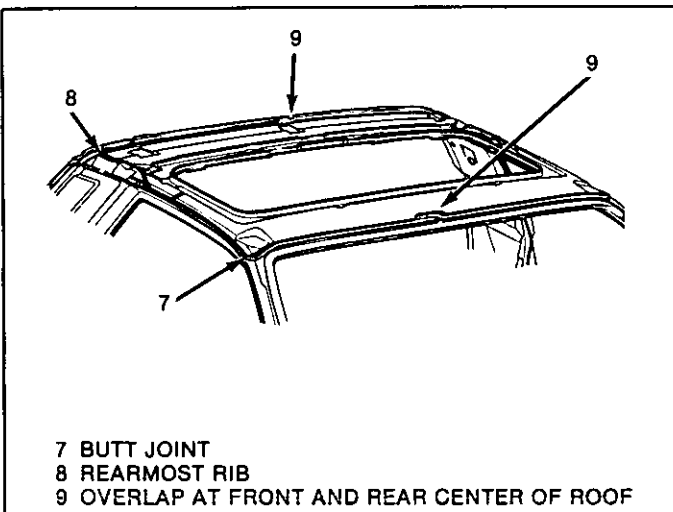

7 BUTT JOINT  
8 REARMOST RIB  
9 OVERLAP AT FRONT AND REAR CENTER OF ROOF

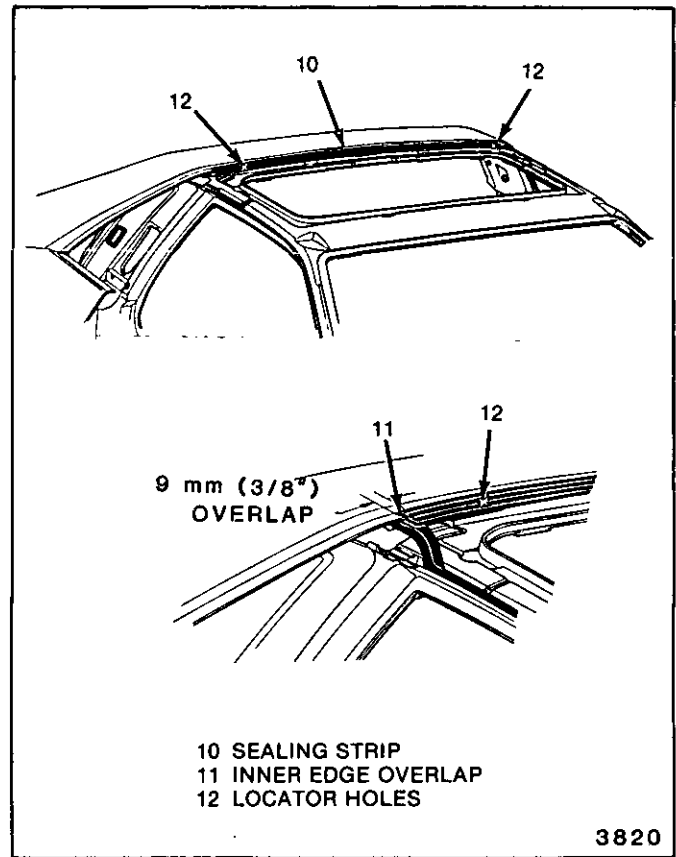

10 SEALING STRIP  
11 INNER EDGE OVERLAP  
12 LOCATOR HOLES

3820

Fig. 8-4-Rear Roof Sealing Strip

3. Roof sealing strips — right side
  - Begin at center of roof above windshield opening (9).
  - Working outward, form a butt joint (7) at pillar sealing strip.
  - Continue alongside of roof to rearmost rib (8) and turn toward rear center of roof.
  - Allow for a 25.0 mm (1 in.) overlap (9) with the left side roof sealing strip.
4. Roof sealing strips — left side
  - Begin at center of roof above windshield opening (9). Overlap adjacent sealing strip by 25.0 mm (1 in.).
  - Working outward, form a butt joint (7) at pillar sealing strip.
  - Continue along side of roof to rearmost rib (8) and turn toward center of roof.
  - Overlap (9) with the right side sealing strip. 25 mm (1 in.)

**Inspect**

- For good contact with surface.

5. Rear roof sealing strip (10) over right and left side roof sealing strips.
  - Overlap right and left roof sealing strips (11) by 9 mm (3/8") at inner edge.

**Important**

www.mopar.com

7. Roof panel (1)
  - Start to lower panel onto frame and insert forward roof panel attachment studs through frame.
  - Align locators (12) in rear roof sealing strip to attaching holes in roof panel (1) and lower roof panel into position on frame.
8. Six roof panel attaching screws (4)

 **Tighten**

- Torque screws (4) to 10 N·m (7.4 ft.-lb.)

9. Two roof panel attaching nuts (4)

 **Tighten**

- Torque nuts (4) to 10 N·m (7.4 ft.-lb.)

10. Two roof panel to cowl panel attaching screws (2)
11. Headlining assembly
12. Dome lamp assembly
13. Sunshade assemblies
14. Upper garnish moldings
15. Windshield assembly. Refer to Section 11.
16. Shroud top vent screen. Refer to Section 4.
17. Wiper arms. Refer to Section 8E in the chassis portion.
18. First three fender to side rail attaching bolts from windshield on right and left fenders.
19. Vista vent assembly (if equipped)
20. Roof drip moldings

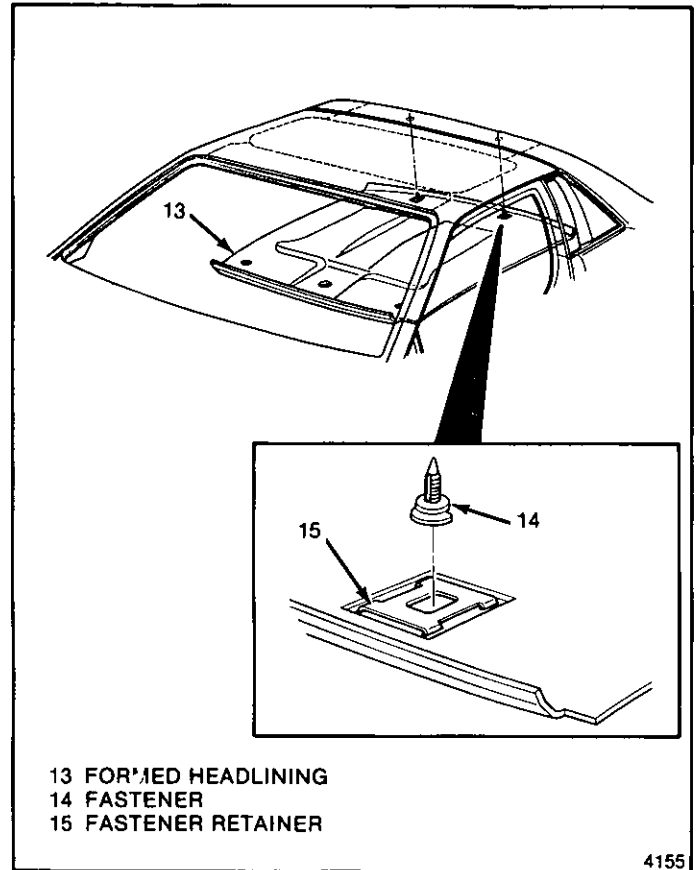

Fig. 8-5-Formed Headlining Installation

## FORMED HEADLINING

The one piece formed headlining consists of molded substrated covered with a foam-backed cloth facing which is common to all models. The one piece construction allows the headlining assembly to be held in place with two fasteners. Final attachment is accomplished by the installation of related hardware and interior moldings.

 **Remove or Disconnect (Figure 8-5)**

1. Sunshade assembly
2. Coat hooks
3. Dome lamp assembly
4. Upper seat belt anchor assemblies
5. Rear quarter trim panels
6. Right and left side upper garnish moldings
7. Vista vent (if equipped)
8. Headlining assembly (13)
  - Pull down on headlining carefully to release fasteners.
9. Two headlining fasteners (14) from fastener retainers (15)

 **Install or Connect (Figure 8-5)**

1. Two fasteners (14) into fastener retainers (15)
2. Dome lamp wiring harness through dome lamp opening
3. Headlining (13) to roof and secure fasteners
4. Rear quarter trim panels
5. Upper seat belt anchor assemblies

 **Tighten**

- Torque anchor bolts to 35 N·m (25.8 ft.-lb.)
6. Right and left side upper garnish moldings
  7. Dome lamp connector to wiring harness
  8. Dome lamp assembly
  9. Coat hooks
  10. Sunshade assembly

## DOME LAMP ASSEMBLY

The dome lamp operates in conjunction with the door jamb switches, instrument panel light switch or the switches mounted on the dome fixture. The dome lamp harness extends up the right windshield pillar and across the roof inner panel to the dome lamp.

 **Remove or Disconnect (Figure 8-6)**

1. Lens assemblies
  - Insert a flat-bladed tool between tab on lens (17) and housing (16)
  - Pry lens loose and remove
2. Bulbs
3. Four housing attaching screws (18)
4. Harness connector (19) from wiring harness (20)

 **Install or Connect (Figure 8-6)**

- As per illustration

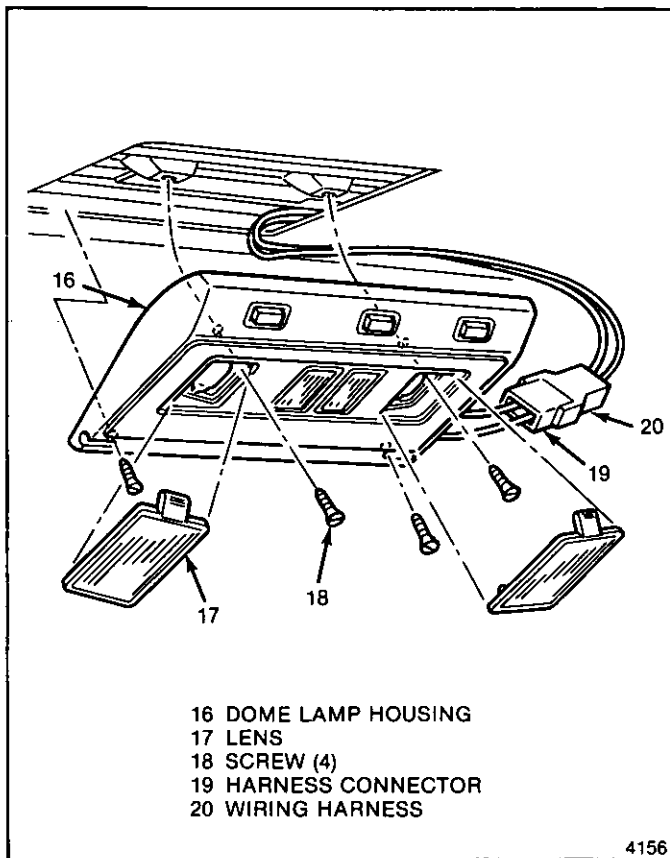

Fig. 8-6-Dome Lamp Assembly

## SUNSHADE ASSEMBLY

The sunshade assemblies are attached to the roof panel with three attaching screws (fig. 8-7).

To remove or install the sunshades (21), remove or install the three attaching screws (22).

## INTERIOR UPPER GARNISH MOLDINGS

The upper garnish molding is constructed of plastic and is painted to match the interior of the vehicle. Plastic and metal clips retain the upper garnish molding to the roof side rail and windshield pillar.

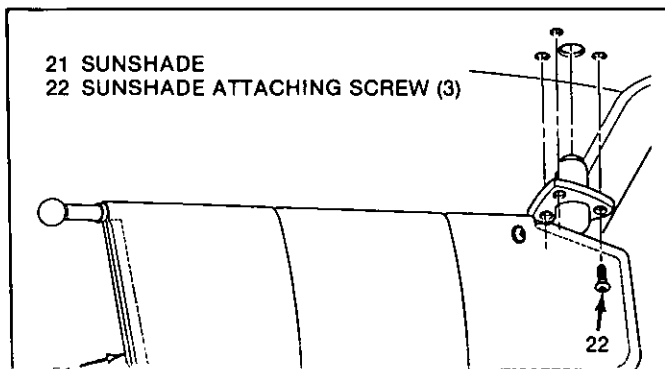

### Remove or Disconnect (Figure 8-8)

1. Upper seat belt anchor assembly
2. Rear quarter trim panel (26) — loosen from upper garnish molding (23)
3. Garnish molding (23)
  - Pull outward and down at rear of garnish molding (23) to disengage from metal clips (25).
  - Pull garnish molding (23) away from windshield pillar to release plastic clips (24).

### Install or Connect (Figure 8-8)

1. Garnish molding (23)
2. Rear quarter trim panel (26)
3. Upper seat belt anchor and bolt

### Tighten

- Torque seat belt anchor bolt to 35 N·m (25.8 ft.lb.)

## ROOF DRIP MOLDINGS

The exterior roof drip molding is a two piece plastic assembly. The roof drip moldings attach along the edge of the roof. A cap drip molding is used to finish off the end of the roof drip molding.

### Remove or Disconnect (Figure 8-9)

1. Roof drip molding (27)
  - Pull out molding at bottom of windshield pillar and continue toward rear of roof
2. Cap drip molding (28)

### Install or Connect (Figure 8-9)

- As per illustration

## VISTA VENT

The optional roof-mounted vista vent assembly is manually operated and consists of a vent glass, two hinges, molding, headlining, escutcheon, and a latch mechanism. The two piece detachable vent latch assembly operates on the over-center principle and doubles as a hold open device. The latch assembly is attached to the glass with screws which pass through the glass and into special shoulder nuts. The screws and nuts are insulated from the glass with protective bushings. The vent glass closes against a weatherstripping.

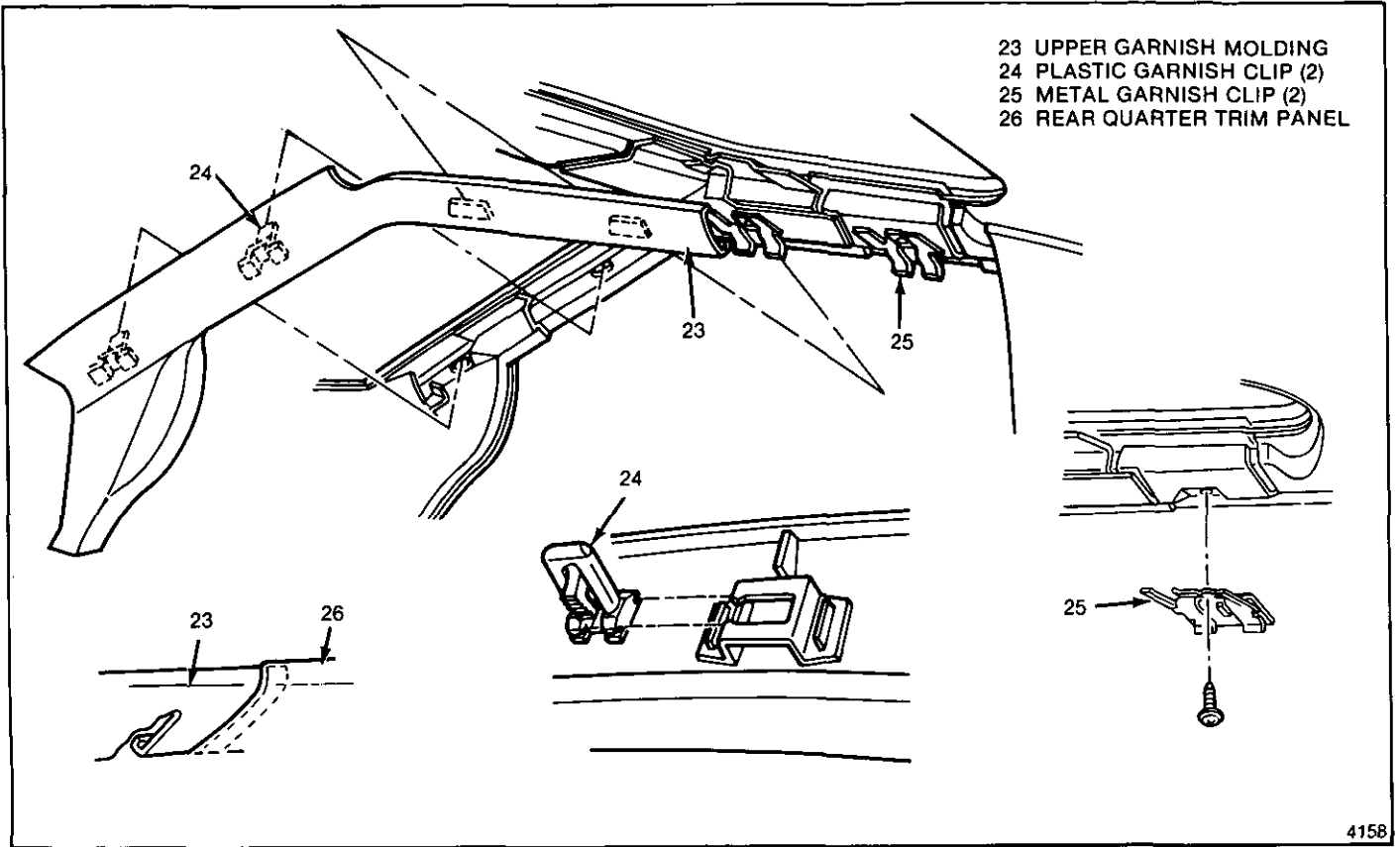

4158

Fig. 8-8-Upper Garnish Molding

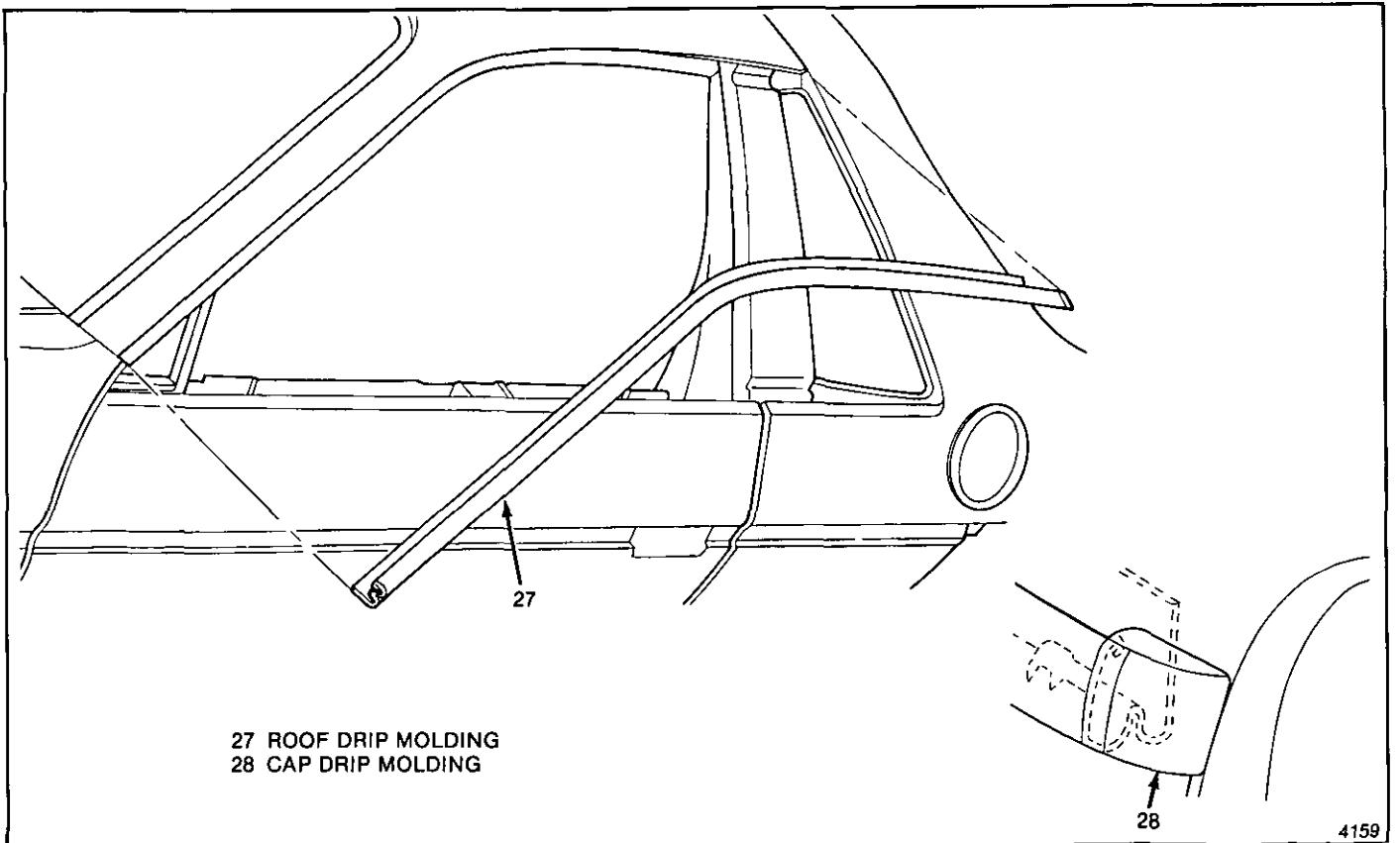

4159

Figure 8-9-Roof Drip Molding

## VISTA VENT GLASS AND HARDWARE

If new glass is to be installed, transfer all hardware from original glass to new glass.

### ↔ Remove or Disconnect (Figure 8-10)

1. Vent glass (29)
2. Glass handle plate (30)
3. Hinge assemblies (31)

### →← Install or Connect (Figure 8-10)

- As per illustration
  - Tighten hinge attaching screws to 5 N·m (3.7 ft.-lbs.).
  - Tighten glass handle plate attaching screws to 6 N·m (4.4 ft.-lbs.).

### 🔑 Adjust (Figure 8-11)

- If glass is high, loosen button assembly attaching nuts (32) and slide a spacer (33) between rear of button assembly (34) and roof panel.

## VISTA VENT HEADLINING RETAINER AND FINISHING LACE

### ↔ Remove or Disconnect (Figure 8-12 and 8-13)

1. Vent glass

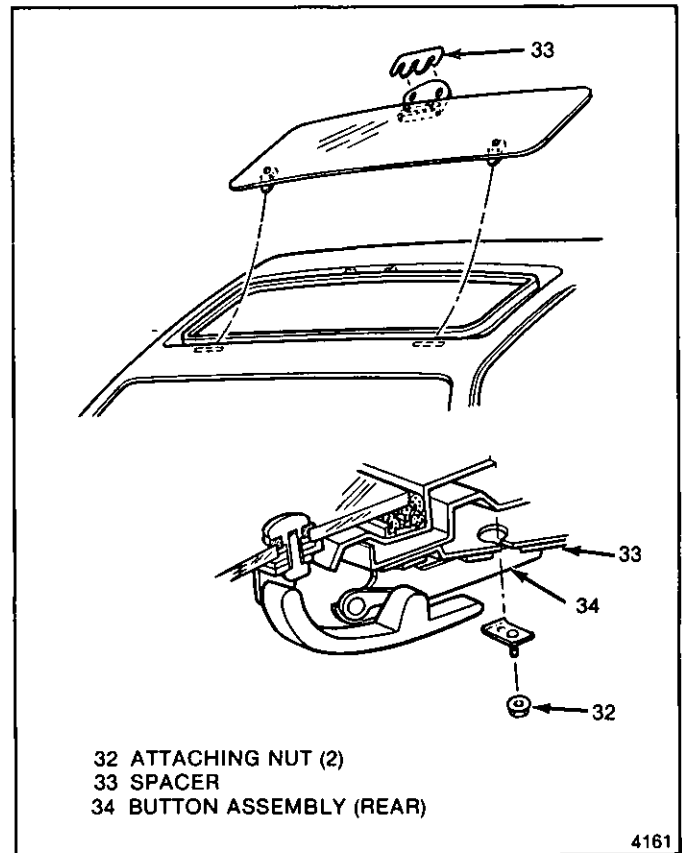
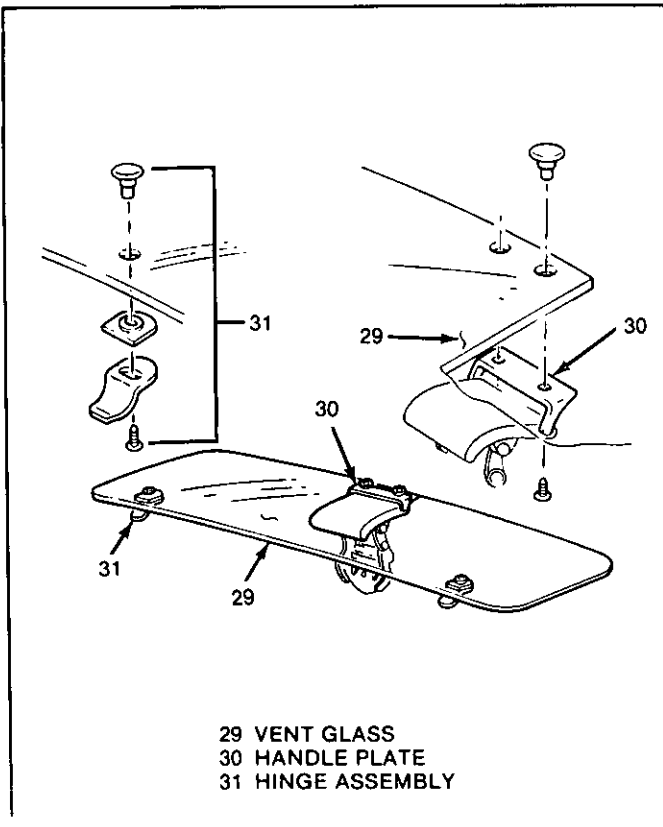

Fig. 8-11-Latch Adjustment

2. Escutcheon (36)
3. Button Assembly (37)
4. Finishing lace (38)
5. Retainer (39)

### →← Install or Connect (Figure 8-12 and 8-13)

1. Headlining retainer (39)
  - start at front center of opening and move outboard in both directions
  - tap retainer into place finishing at rear handle location
2. Headlining into retainer (39)
3. Finishing lace (38)
  - start at rear center
  - apply pressure to force lace over retainer from front to rear
4. Button assembly (37)
5. Escutcheon (36)
6. Vent glass

## VENT GLASS WEATHERSTRIP

### ↔ Remove or Disconnect (Figure 8-14)

1. Vent glass
2. Weatherstrip (35)



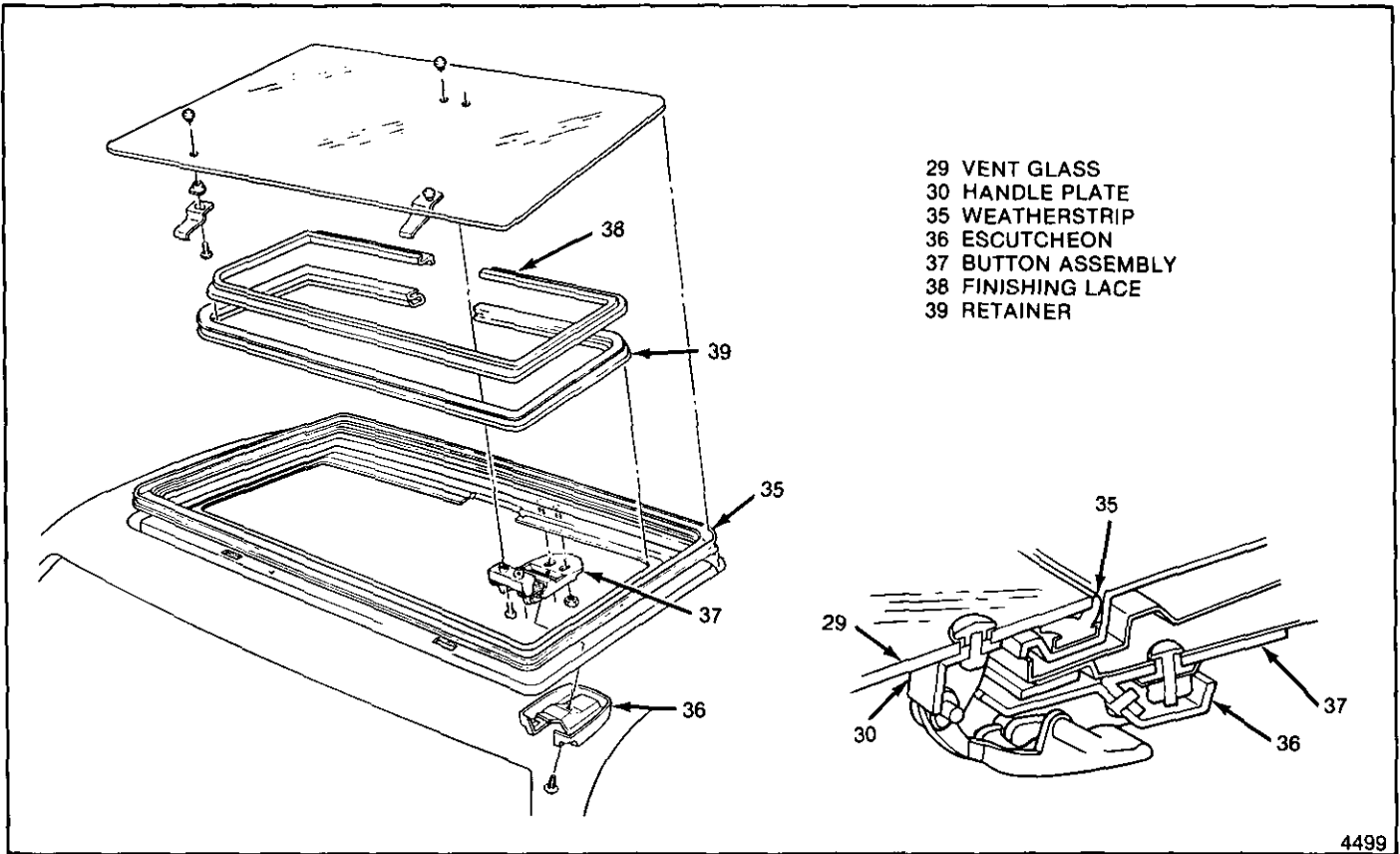

Fig. 8-12-Vista Vent Assembly

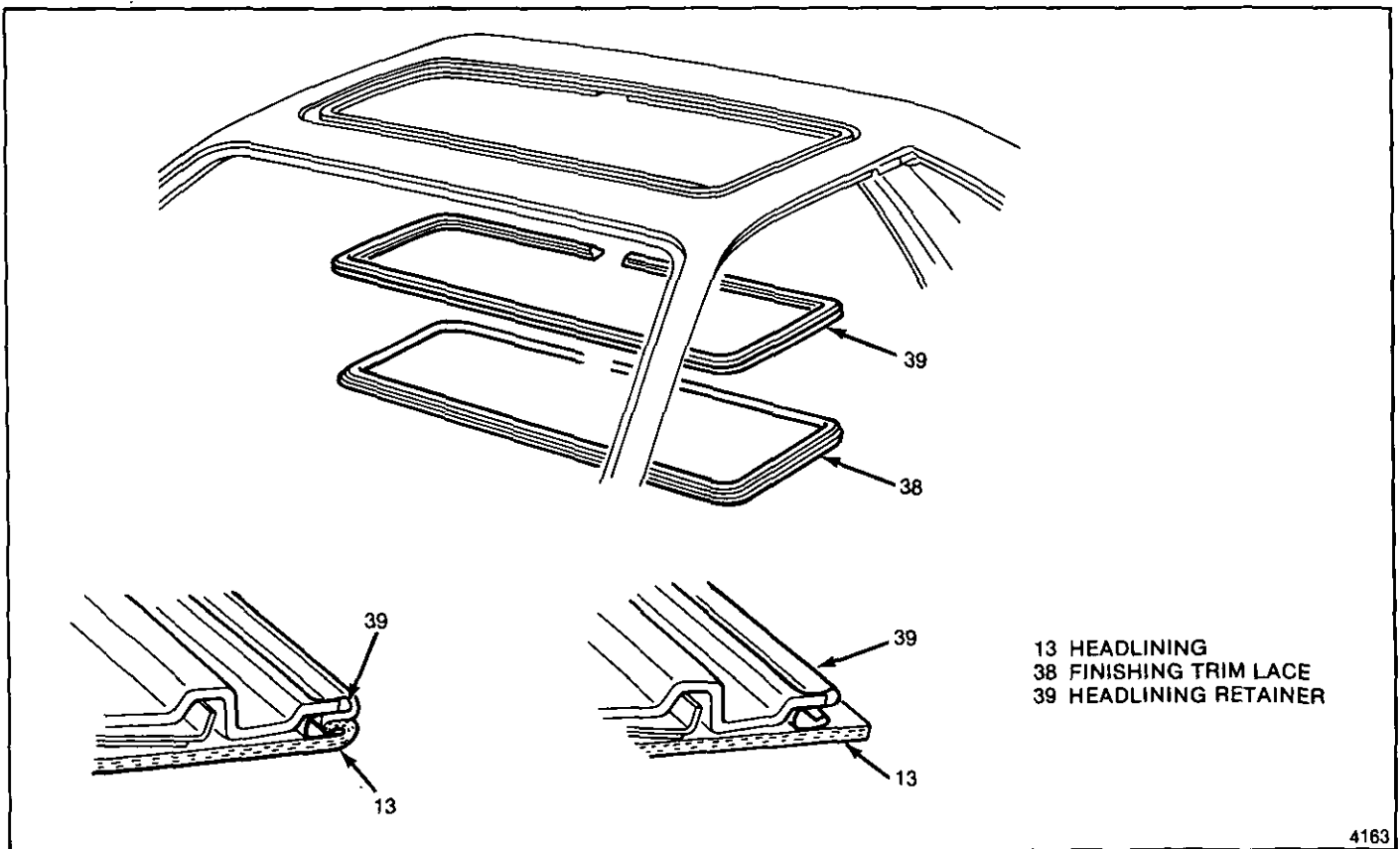
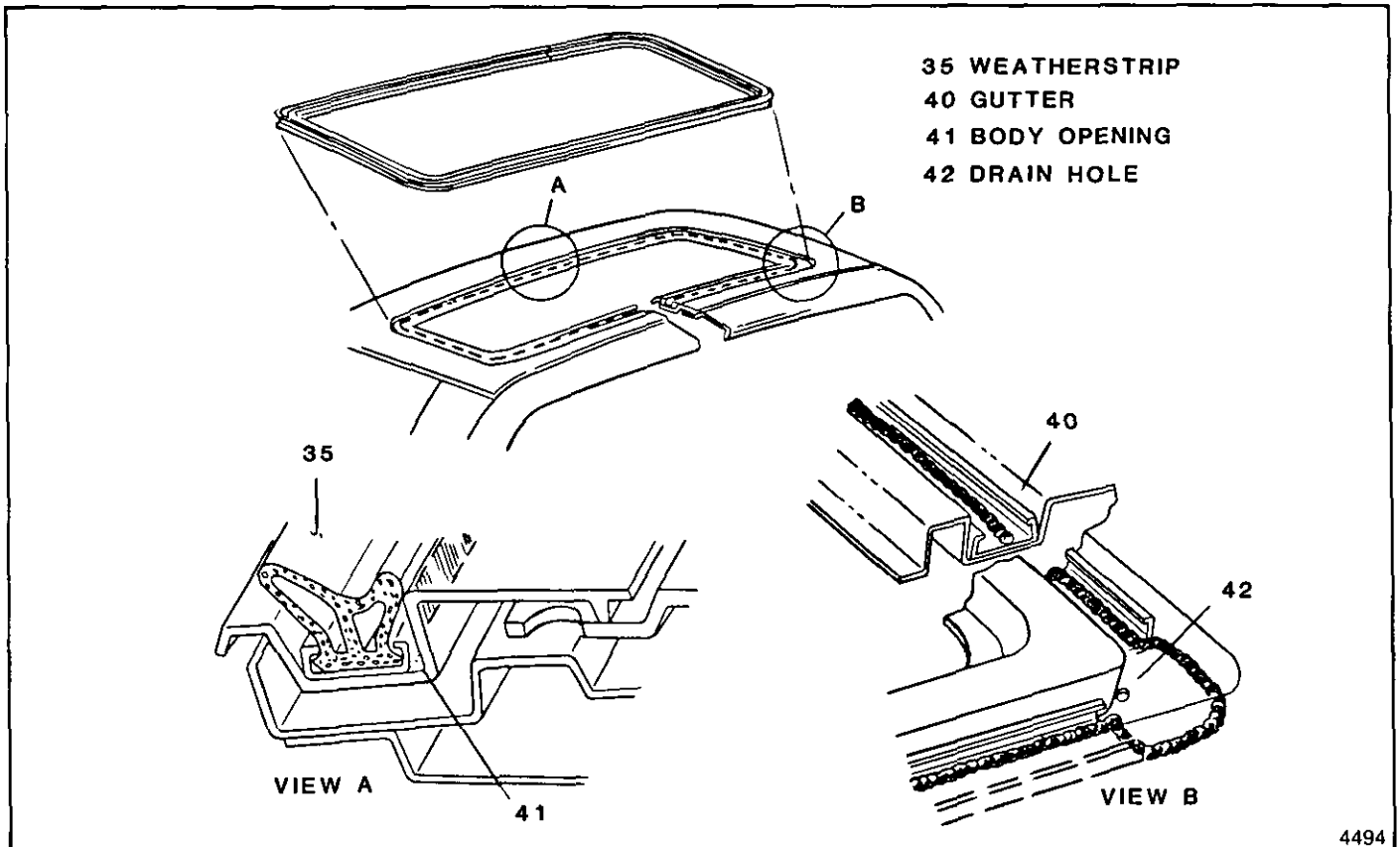

Fig. 8-13-Vista Vent Headlining Retainer Installation

**Install or Connect (Figure 8-14)**

1. Adhesive to gutter (40)
2. Adhesive to weatherstrip (35)
3. Weatherstrip
  - o Allow adhesive to become tacky before installation.
4. Apply a bead of adhesive between outboard periphery of weatherstrip and body opening (41) to prevent water seepage. Do not plug drain holes.

5. Watertest — with a soft spray of warm or hot water.



4494

Fig. 8-14-Vista Vent Weatherstrip Installation

## SECTION 9

## SEATS

**NOTICE:** All lap, shoulder and seat assembly fasteners are important attaching parts in that they could affect the performance of vital components and systems, and/or could result in major repair expense. They must be replaced with one of the same part number or with an equivalent part if replacement becomes necessary. Do not use a replacement part of lesser quality or substitute design. Torque values must be used as specified during reassembly to assure proper retention of these parts.

## CONTENTS

Restraint Systems .....	9-1	Seatback Assembly .....	9-3
Lap and Shoulder Belts .....	9-1	Seat Torque Specifications .....	9-3
Comfort Lock Operational Checks and Requirements .....	9-1	Seat Adjustments at Floor Pan Attachment .....	9-4
Child Seat Top Strap Anchor .....	9-2	Seat Adjuster Control Arm Knob .....	9-4
Seats .....	9-2	Seat Assembly .....	9-4
Reclining Seatback .....	9-2	Seat Adjuster Assembly .....	9-5
Recliner Control Mechanism .....	9-3	Manual Seat Adjuster Diagnosis Chart .....	9-7

## RESTRAINT SYSTEMS

## LAP AND SHOULDER BELTS

The seat belts incorporate a 4-to-8 second fasten seat belt reminder lamp and sound signal designed to remind the driver if the lap and shoulder belts are not fastened when the ignition is turned to the on position. If the driver's seat belt **is buckled**, the alarm will not operate; however, the fasten seat belt reminder lamp will stay on for a 4-to-8 second period. If the driver's seat belt **is not buckled**, the reminder lamp and sound signal will automatically shut off after a 4-to-8 second interval.

The single loop belt system consists of a single continuous length of webbing. The webbing is routed from the anchor (at the rocker panel), through a self-locking latch plate (at the buckle), around the guide assembly (at the top of the center pillar or quarter panel) and into a retractor in the lower area of the center pillar or quarter inner. The emergency locking feature of the retractor remains unlocked to allow free movement of the occupant's upper body while the vehicle is being operated. When the vehicle decelerates or changes direction abruptly, the single loop belt(s) is locked in position by a pendulum that causes a locking bar to engage a cog of the retractor mechanism.

The retractor has a comfort lock feature that allows the occupant to adjust the shoulder belt for proper fit and comfort. When engaged, the comfort lock prevents full retraction of the webbing to eliminate occupant discomfort due to webbing load on the shoulder. The occupant can readjust the comfort lock during vehicle operation as described below. Whenever the occupant's door is opened, the comfort lock is automatically unlocked so the webbing can fully retract to the stowed position. This is controlled by the

comfort lock plunger located at the lower front side of the center or lock pillar.

When servicing or replacing lap and shoulder belts of the single loop system, refer to the following precautionary items:

- Lap and shoulder belts will be serviced as follows:
  1. Retractor portion of lap and shoulder belt for passenger and driver.
  2. Buckle portion of seat lap belt for passenger and driver.
- Keep sharp edges and damaging objects away from belts.
- Avoid bending or damaging any portion of the belt buckle or latch plate.
- Do not bleach or dye belt webbing (clean with mild soap solution and water).
- When installing lap or shoulder belt anchor bolts, start bolt by hand to assure that bolt is threaded straight.
- Do not attempt repairs on lap or shoulder belt retractor mechanisms or belt retractor covers. Replace with new service replacement parts.
- Refer to Figures 9-1 through 9-4 and tighten **all** seat and shoulder belt anchor bolts as specified.

## Comfort Lock Operational Checks and Requirements

 Important

The shoulder belt *comfort lock* feature must function as follows:

- With the door closed, extend the webbing from the retractor to a distance approximating buckled position.
- Let the belt retract a minimum of 178 mm (7").

## 9-2 SEATS

- Extract the belt from 25 mm to 76 mm (1" to 3") and release the belt. The comfort lock must engage and prevent retraction.
- Extract belt 25 mm to 76 mm (1" to 3") and release. The belt must return to the comfort lock position previously set. Full retraction is a failure of the system.
- Extract belt 178 mm (7") and release. The belt must fully retract without locking.

### ↔ Remove or Disconnect (Figures 9-1, 9-2)

1. Rocker anchor plate (1)
2. Trim cover (2) and upper guide anchor plate (3)
3. Rear quarter trim panel
4. Belt warning harness connector (4) from belt warning connector (5)
5. Retractor (6)
6. Seat lap belt (7)

### ↔ Install or Connect (Figure 9-1, 9-2)

1. Seat lap belt (7)
2. Retractor (6)

#### Tighten

Retractor and lap belt attaching bolts from 35 to 48 N·m (26 to 35 ft-lb)

3. Belt warning harness connector (4) to belt warning connector (5)
4. Rear quarter trim panel
5. Upper guide loop anchor plate (3)

#### Tighten

Upper anchor plate bolt from 35 to 48 N·m (26 to 35 ft-lb)

6. Trim cover (2)
7. Pull upper belt inboard so that the stitched sew stop is exposed and beyond the guide loop anchor plate (3).
8. Rocker anchor plate (1)

#### Tighten

Rocker anchor plate bolt from 35 to 48 N·m (26 to 35 ft-lb.)

## CHILD SEAT TOP STRAP ANCHOR

If use of a child seat is desired, a special dealer-installed anchor must be used to secure the child seat top strap. The following instructions explain how to install the anchor for the child seat top strap.

### Top Strap Anchor (Fig. 9-3)

All hardware discussed should be available from the child seat manufacturer. Be sure the child seat position does not conflict with any additional requirements provided by its manufacturer, or with any recommendations in the Child Restraint section of the Owner's Manual.

2. Position passenger seat full forward.
3. Using the 2-1/2" washer, locate the washer as shown in view A and mark the center of the washer hole.

#### Important

Washer should be located in upper corner of triangle formed by battery bracket (1) and stiffener bead (2).

4. Drill a 9 mm (11/32") hole as marked in step #3 through engine compartment forward panel.

**CAUTION: Any holes penetrating to the exterior of the vehicle must be sealed to prevent carbon monoxide from entering the vehicle. Suitable sealers include silicone, butyl or acrylic type caulking. In the event that the child seat anchor bracket is removed, the bolt hole penetrating to the exterior of the vehicle must be resealed.**

5. Apply body sealer (5) around engine compartment side of 9 mm (11/32") hole.
6. Install top strap anchor bracket (4), bolt (3), washer (6) and locknut (7). Tighten locknut.
7. Replace battery.

## SEATS

The seat cushions and backs have formed foam pads which fit the contours of the full panel seatback frame assembly and also the designed contour of the seat cushion frame.

There are **no** front seat forward or rearward relocation provisions provided at either seat adjuster-to-floor pan attachments or seat adjuster-to-seat frame attachments.

**Do not** attempt to change the designed seat position by altering the designed seat adjuster-to-floor pan anchor provisions or seat adjuster-to-seat frame anchor provisions as it could affect the performance of the seat system.

## RECLINING SEATBACK

The tubular frame seatback has a single side, recliner control mechanism. This recliner mechanism, which is mounted on the outboard side of the seat, is the sole control of the seatback. The inner hinge arm attaching bolt acts only as a point of rotation for the seatback.

To recline the seatback, rearward pressure must be applied to the seatback **before** lifting the recliner release handle. When pressure is applied against the seatback, the lockout lever tab disengages from the cam plate tab. Then the release handle can be moved, allowing the seatback to move rearward. Releasing the handle will allow the cam plate to move counterclockwise and cause the sector lock teeth to engage the upper hinge arm, locking the seatback in the desired reclined position.

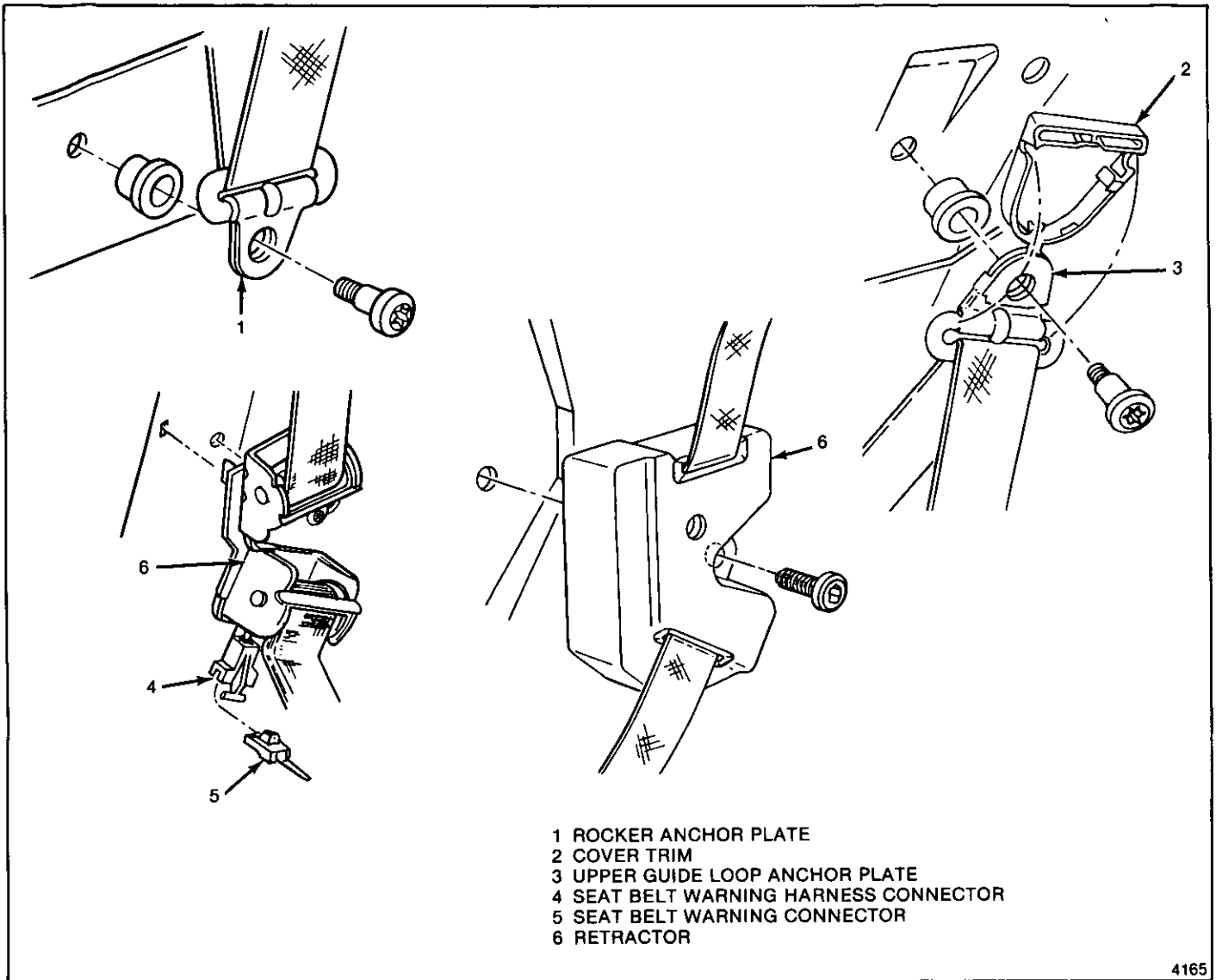

Fig. 9-1-Single Loop Belt System

4165

## RECLINER CONTROL MECHANISM

### ↔ Remove or Disconnect (Figure 9-4)

1. Place seatback in full-up position
2. Recliner mechanism cover bolts (8)
3. Recliner mechanism cover (9)
4. Recliner control mechanism (10)

### →← Install or Connect (Figure 9-4)

1. Seatback in full-up position
2. Recliner control mechanism (10)
3. Recliner mechanism cover (9)
4. Recliner mechanism cover bolts (8)

## SEATBACK ASSEMBLY

### ↔ Remove or Disconnect (Figure 9-4)

1. Seat assembly
2. Recliner mechanism cover (9) and attaching bolt (8)

3. Inner hinge arm attaching bolt (11)

4. Seatback

### →← Install or Connect (Figure 9-4)

1. Seatback
2. Inner hinge arm attaching bolt (11)
3. Recliner mechanism cover bolts (8) and cover (9)
4. Seat assembly

### 👁 Inspect

- For proper operation
- Ease of lever operation and seatback movement
- Positive locking action
- Release lever should always return to normal position.

## SEAT TORQUE SPECIFICATIONS

The following torque specifications should be used when servicing seat assemblies.

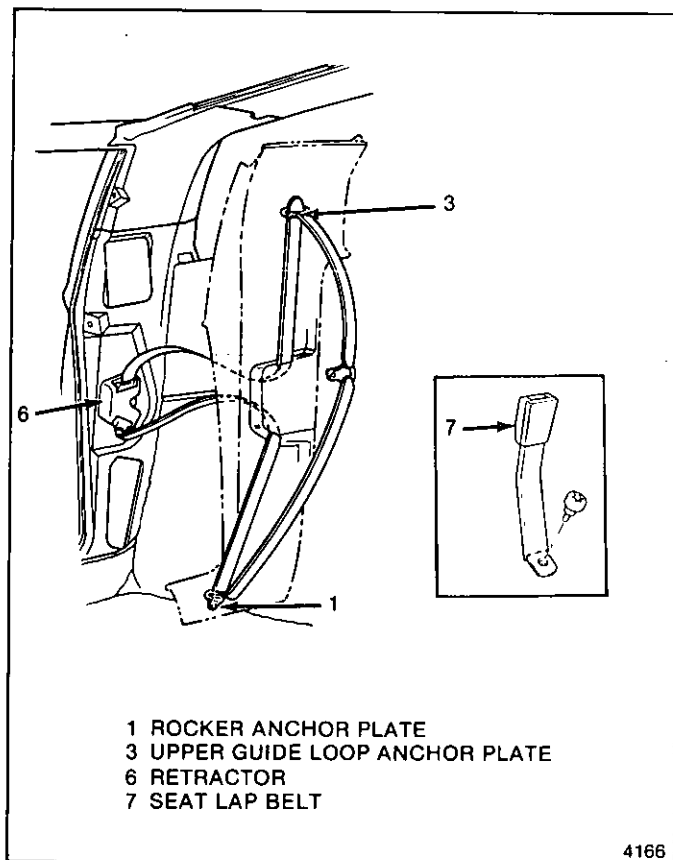

Fig. 9-2-Retractor Assembly

### Bolt or Nut Location and Torque

Many service replacement assemblies such as seat cushion and back frame assemblies may have unthreaded nuts for attachment of seat adjusters, seatback and lap belts. Threads must be formed in these unthreaded nuts with either the original or a new proper size thread forming bolt (metric bolts and nuts are color coded blue). Apply 67 to 89 newtons (15 to 20 pounds) of straight-in pressure to start thread forming action of bolt into an unthreaded nut (Figure 9-5).

**NOTICE:** See Notice on page 9-1 of this section.

- Seat adjuster-to-floor pan nuts (8 mm #11500401) - 20 to 28 N·m (15 to 21 ft-lb)
- Seat adjuster-to-seat frame bolts (8 mm x 20 mm #2009759) - 20 to 28 N·m (15 to 21 ft-lb)
- Front seatback frame to recliner mechanism - 20 to 28 N·m (15 to 21 ft-lb)
- Seatback inner pivot hinge arm to seat cushion frame - 20 to 28 N·m (15 to 21 ft-lb)
- Retractor seat belt bolt to quarter inner panel - 35 to 48 N·m (26 to 35 ft-lb), type 2 bolt
- Seat buckle side belt to body 35 to 48 N·m (26 to 35 ft-lb), type 8 bolt
- Rocker anchor plate to body side frame - 35 to 48 N·m (26 to 35 ft-lb), type 7 bolt

### Seat Adjustments at Floor Pan Attachment

A small amount of fore and aft or side adjustment is available at the seat adjuster-to-floor pan attaching bolts which can be used towards alignment of the seat assembly or alignment of the seat adjusters with each other. This adjustment can be used to help correct the following conditions:

- Hard or slow operation due to adjusters not being parallel with each other.
- Seat assembly slightly too far to right or left.

### SEAT ADJUSTER CONTROL ARM KNOB

Manual seat adjuster control arm knobs are a press fit on the adjuster control arm. If removing or installing a control knob or a trimmed seat assembly, place a protective cover over trim material in area of knob.

#### ←→ Remove or Disconnect (Figure 9-6)

Using a body spoon (12) and locking pliers (13), pry off knob.

#### →← Install or Connect

1. Make a pencil mark on seat adjuster to use as a guide for full depth.
2. Secure locking pliers to control arm below pencil line
3. Insert knob (14) and press firmly while holding restraint with locking type pliers. If necessary use rubber mallet or 4" C clamp.

### SEAT ASSEMBLY

Seat assemblies are secured to the floor pan by nuts installed into weld studs on the floor pan anchor plate studs.

The seat assemblies have manual seat adjusters to provide fore and aft movement of the seat. When the control lever located at the front of the seat is actuated to the left, the seat adjusters unlock to permit horizontal travel of the seat. When the seat is in the desired position and the locking lever is released, the seat is locked. See Diagnosis Chart.

#### ←→ Remove or Disconnect (Figure 9-7)

1. Move seat to forward position
2. Adjuster-to-floor pan rear attaching nuts (15)
3. Move seat to rearward position
4. Adjuster-to-floor pan front attaching nuts (16)
5. Seat assembly (17)

#### →← Install or Connect (Figure 9-7)

1. Seat assembly (17)
2. Move seat to rearward position
3. Adjuster-to-floor pan front attaching nuts (16)

#### ⌚ Tighten

Front floor pan nuts (16) from 20 to 28 N·m (15

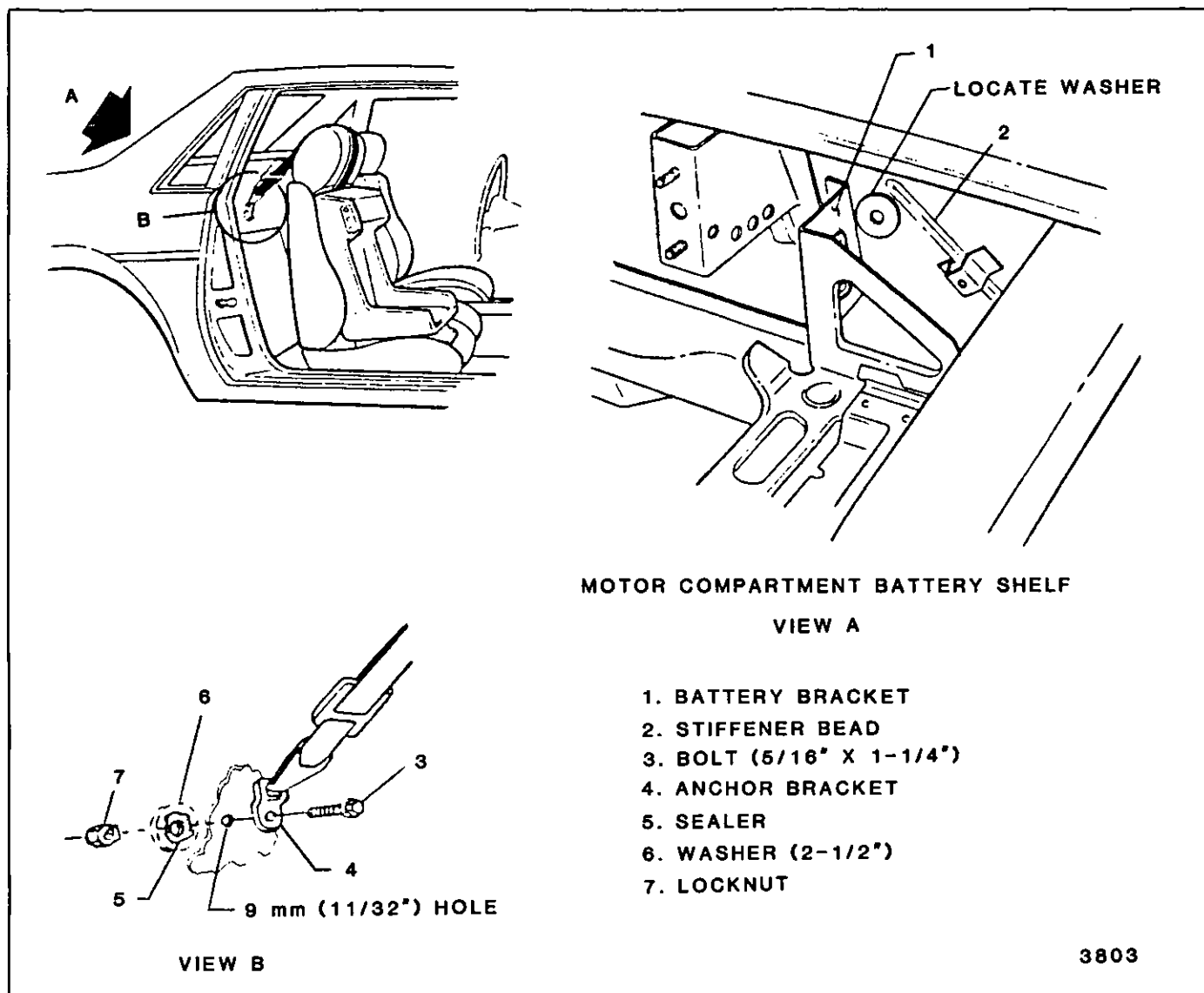

Fig. 9-3-Top Strap Anchor Installation

5. Adjuster-to-floor pan rear attaching nuts

 Tighten

Rear floor pan nuts (15) from 20 to 28 N·m (15 to 21 ft-lb)

 Inspect

For proper operation of seat assembly

### SEAT ADJUSTER ASSEMBLY

 Remove or Disconnect (Figure 9-7)

1. Seat assembly with adjuster attached and place upside down on a clean surface
2. Adjuster-to-seat bottom frame front and rear attaching bolts (18)

3. Seat adjuster (19) from seat

 Install or Connect (Figure 9-7)

1. Seat adjuster (19) to seat
2. Adjuster-to-seat bottom frame, front and rear attaching bolts (18)

 Tighten

Adjuster-to-seat bolts (18) from 20 to 28 N·m (15 to 21 ft-lb)

3. Seat assembly (17)

 Inspect

For proper operation of seat adjuster assembly

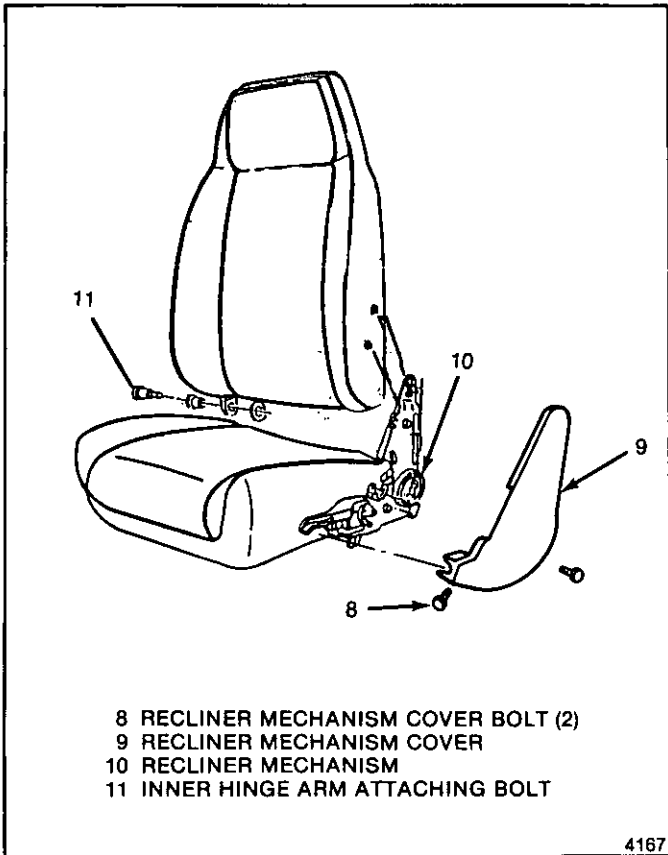

Fig. 9-4-Recliner Mechanism

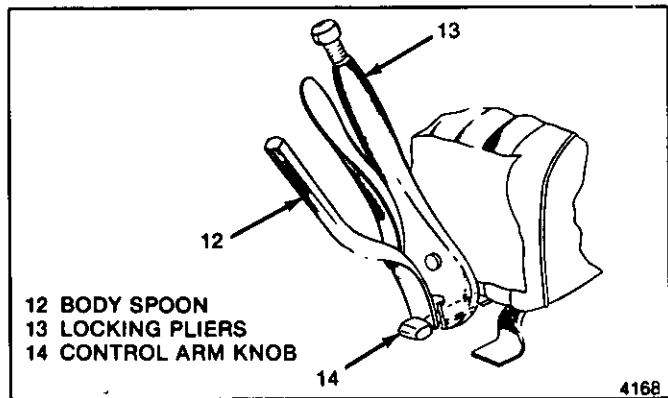

Fig. 9-6-Seat Adjuster Control Knob

	PART NAME	METRIC TYPE	THREAD	LENGTH (mm)	TORQUE	
					N·m	ft·lbs
	BOLT	1	M12-1.75	36	35-48	26-35
	BOLT	2	M12-1.75	25	35-48	26-35
	BOLT	3	M12-1.75	30	35-48	26-35
	BOLT	4	M8-1.25	20	20-24	15-17
	BOLT	5	M12-1.75	39	35-48	26-35
	BOLT	6	M12-1.75	35	35-48	26-35
	BOLT	7	M12-1.75	43	35-48	26-35
	BOLT	8	M12-1.75	31	35-48	26-35
	BOLT	9	M12-1.75	49	35-48	26-35
	STUD	10	M6-1.00	15	N/A	N/A
	BOLT	11	M12-1.75	53	35-48	26-35
	NUT	12	M12-1.75		35-48	26-35
	NUT	13	M10-1.50		30-40	22-29
	NUT	14	M6-1.00		10-14	7-10
	NUT	15	M8-1.25		18-25	14-19
	STUD	16	M8-1.25	13	N/A	N/A

NOTICE  
 SEE NOTICE ON PAGE 9-1

**3649**

Fig. 9-5-Seat Belt Fastener Chart



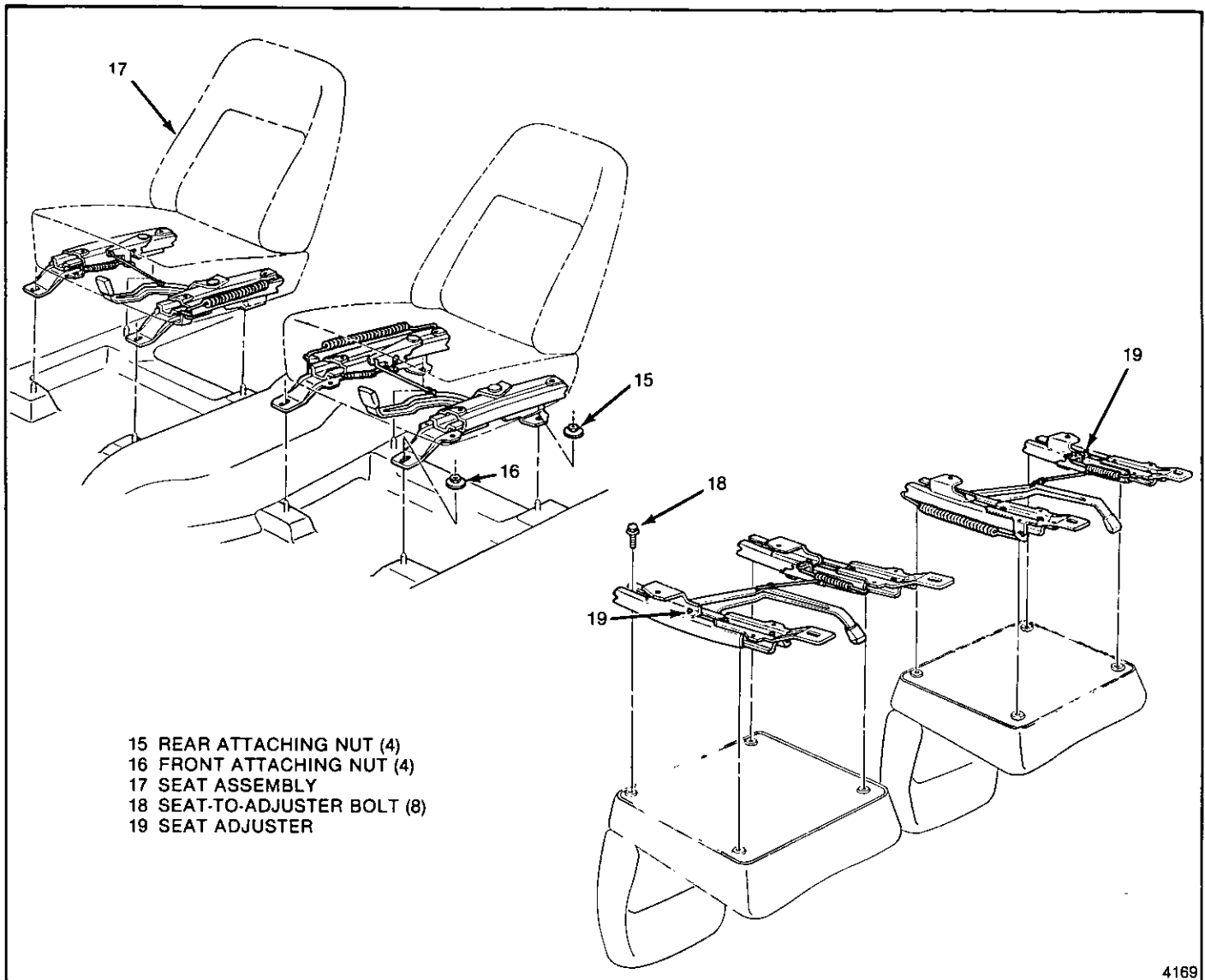

Fig. 9-7-Seat Assembly

4169

## MANUAL SEAT ADJUSTER DIAGNOSIS CHART

CONDITION	APPARENT CAUSE	CORRECTION
1. Adjuster will not lock.	1. Locking wire too tight.	1. Loosen locking wire tension enough to provide full engagement of lock bar in locking slots of adjuster lower channel.
	2. Adjuster lock bar spring disconnected or broken.	2. Connect spring or install new spring.
	3. Adjuster lock bar sticking or binding.	3. Lubricate lock bar pivot. If bar is binding, eliminate cause of binding or replace adjuster.

## 9-8 SEATS

---

2. Adjuster will not unlock.	1. Locking wire too loose or disconnected.  2. Adjuster lock bar sticking or binding.	1. Tighten locking wire enough to allow lock bar to disengage from locking slots in adjuster lower channel when lock control lever is activated. 2. Lubricate lock bar pivot. If bar is binding, eliminate cause of binding or replace adjuster.
3. When left adjuster locks, right adjuster is between lock positions.	1. Right adjuster either rearward or forward of left adjuster.	1. Loosen adjuster to floor pan bolts or nuts. Move one adjuster forward or rearward as far as possible and the other adjuster the opposite direction.
4. Seat hard to move forward or rearward.	1. Adjusters new, not broken in.  2. Adjuster(s) improperly lubricated.  3. Adjuster(s) binding due to bent or damaged channels. 4. Adjusters not in parallel alignment with each other.	1. Operate seat to full-forward and full-rearward positions several times to work new tightness out of channels. 2. Lubricate adjuster channels with Lubriplate Auto-Lube A or equivalent. 3. Replace adjuster.  4. Loosen floor pan attaching bolts or nuts, align adjusters parallel on floor pan and retighten bolts or nuts.

---

# SECTION 10

# ELECTRICAL

## CONTENTS

Rear Window Defogger .....	10-1
Testing Grid Lines .....	10-1
Grid Line Repair .....	10-1
Braided Wire Lead Repair .....	10-2
Wiring Harness Illustrations .....	10-3/13
Circuit Abbreviations .....	10-14

### REAR WINDOW DEFOGGER

The optional rear window defogger system consists of a glass containing horizontally positioned ceramic, silver compound element lines and vertical bus bars baked into the inner surface during the glass forming operation. Braided wire is soldered to the bus bars on each side of the glass. The feed wire terminal is soldered to the bus bar. The lead wires (stranded, round wire) are spliced to the braided wire and are covered with an extruded plastic sleeve to insulate them from body metal.

The defogger operates on 12 volts with a current draw of approximately 9 amps when the glass is at 24°C (75°F). Under some conditions, heat from the glass may not be detected by finger touch. The length of time required to remove interior fog from the rear window will vary with such conditions as vehicle speed, outside glass temperature, atmospheric pressure, and number of passengers.

This system is activated by an instrument panel mounted switch with an integral indicator lamp. A timer module is also used to control the time of heated glass operation.

The system will operate approximately ten minutes after activation and is automatically turned off by the timer module. The system can also be turned off during this operating period by turning either the instrument panel mounted switch or ignition switch to off.

Refer to Section 8A in the chassis portion of this manual for complete circuit diagrams on this system.

#### Testing Grid Lines

To locate inoperative grid lines, start the engine and turn on the rear window defogger system. Ground one test lamp lead and lightly touch the other prod to each grid line. Figure 10-1 illustrates the pattern of test lamp brilliance to be expected with a properly functioning grid.

If the test lamp bulb shows full brilliance at both ends of grid lines, check for a loose ground wire contact to body metal.

The range zones in Figure 10-1 may vary slightly from one glass to another; however, the bulb brilliance will decrease proportionately to the increased

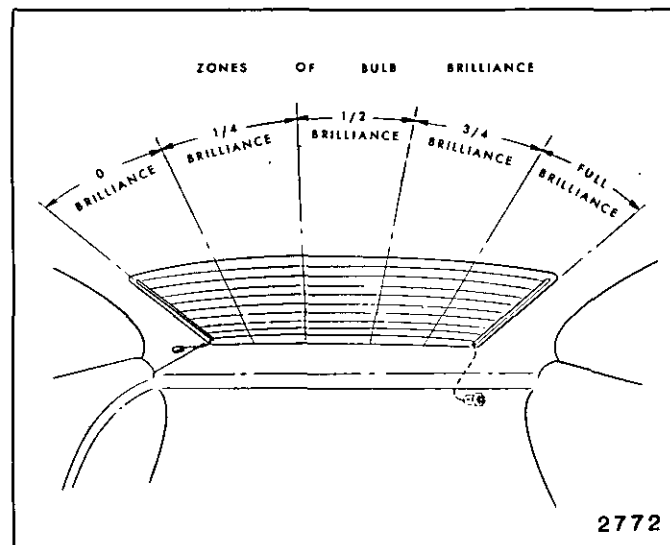

Fig. 10-1-Test Lamp Bulb Brilliance Zones - Normal Operating Rear Window Defogger

resistance in the grid line as the prod is moved from the left bus bar to the right.

All grid lines must be tested in at least two places to eliminate the possibility of bridging a break. For best results, contact each grid line a few inches either side of the glass centerline. If an abnormal light reading is apparent on a specific grid line, place the test lamp prod on that grid at the left bus bar and move the prod toward the right bus bar until the test light goes out indicating a break in the continuity of the grid line (Fig. 10-2).

#### Grid Line Repair

Tools Required:

- Part No. 1052858 (or equivalent) - Rear Window Defogger Repair Kit
- Heat Gun - Capable of 260°C (500°F)

#### ↔ Remove or Disconnect

Battery feed - rear window defogger system

#### 🔍 Inspect

- Rear window defogger grid lines.
- Mark grid line breaks on outside of glass with grease pencil.

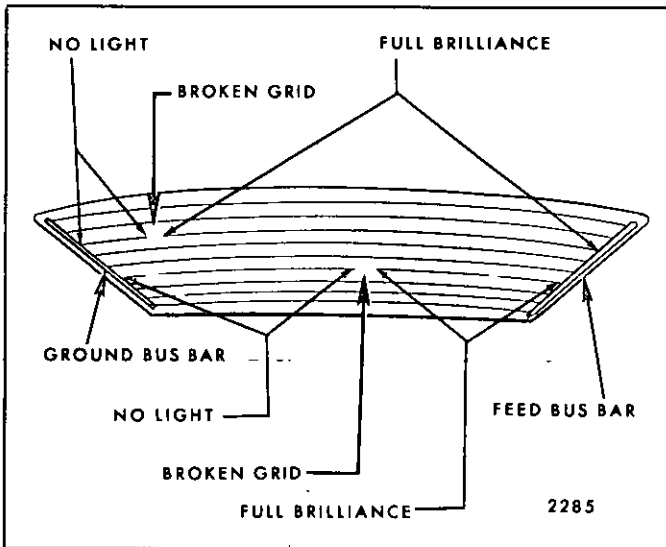

Fig. 10-2-Test Lamp Bulb Brilliance with Broken Grid Lines

**Clean**

Grid line area to be repaired. Buff with steel wool and wipe clean using cloth dampened with alcohol. Buff and clean about 6 mm (1/4") beyond each side of break in guide line.

**Install or Connect (Figures 10-3 and 10-4)**

1. Grid line repair decal or two strips of tape positioned above and below repair area.
  - Repair decal or tape **must** be used to control width of repair area
  - If decal is used, be sure the die-cut metering slot is the same width as the grid line.
2. Remove the clamp (separator) from the container of grid repair material.
  - Mix hardener and silver plastic thoroughly.
  - If hardener has crystalized, immerse packet in hot water until the hardener reliquifies.
3. At room temperature, apply grid repair material to repair area using a small wood stick or spatula.
4. Carefully remove the decal or tape.

**NOTICE:** The grid line repair material must be cured with heat. To avoid heat damage to interior trim, protect the trim near the repair area where heat is to be applied.

5. Apply heat to repair area for 1 to 2 minutes
  - Hold heat gun nozzle 25 mm (1") from surface.
  - A minimum temperature of 149°C (300°F) is required.

**Inspect**

Grid line repair area. If repair appears discolored, apply a coating of tincture of iodine to repair area using a pipe cleaner or fine brush. Allow iodine to dry for about 30 seconds and carefully wipe off excess with lint free cloth.

6. Test rear defogger operation to verify grid line repair.

**NOTICE:** At least 24 hours are required for complete curing of repair materials. The unit should not be physically disturbed until after that time.

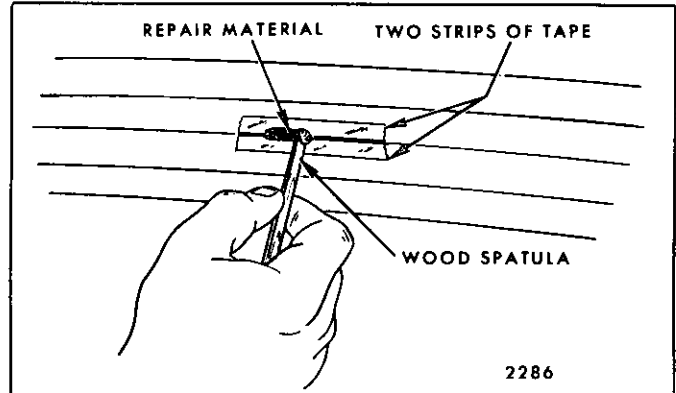

Fig. 10-3-Applying Repair Material to Broken Grid Line

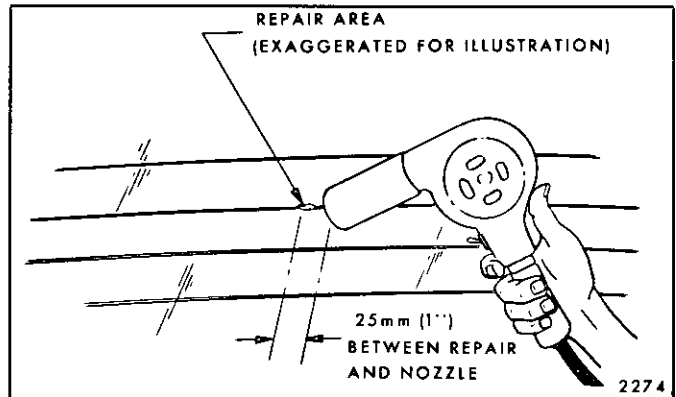

Fig. 10-4-Applying Heat to Grid Line Repair

**Braided Wire Lead Repair**

The rear defogger bus bar lead wire can be reattached by resoldering using a solder containing 3% silver and a rosin flux paste.

- Before soldering the bus bar, repair area should be buffed with fine steel wool. This removes the oxide coating formed during glass manufacture.
- Apply the paste-type rosin flux in small quantities to the wire lead and bus bar repair area using a brush.
- The soldering iron tip should be coated with solder beforehand. Use only enough heat to melt the solder and only enough solder to ensure a complete repair.
- Do not overheat the wire when resoldering it to the bus bar.

# CROSS CAR WIRING

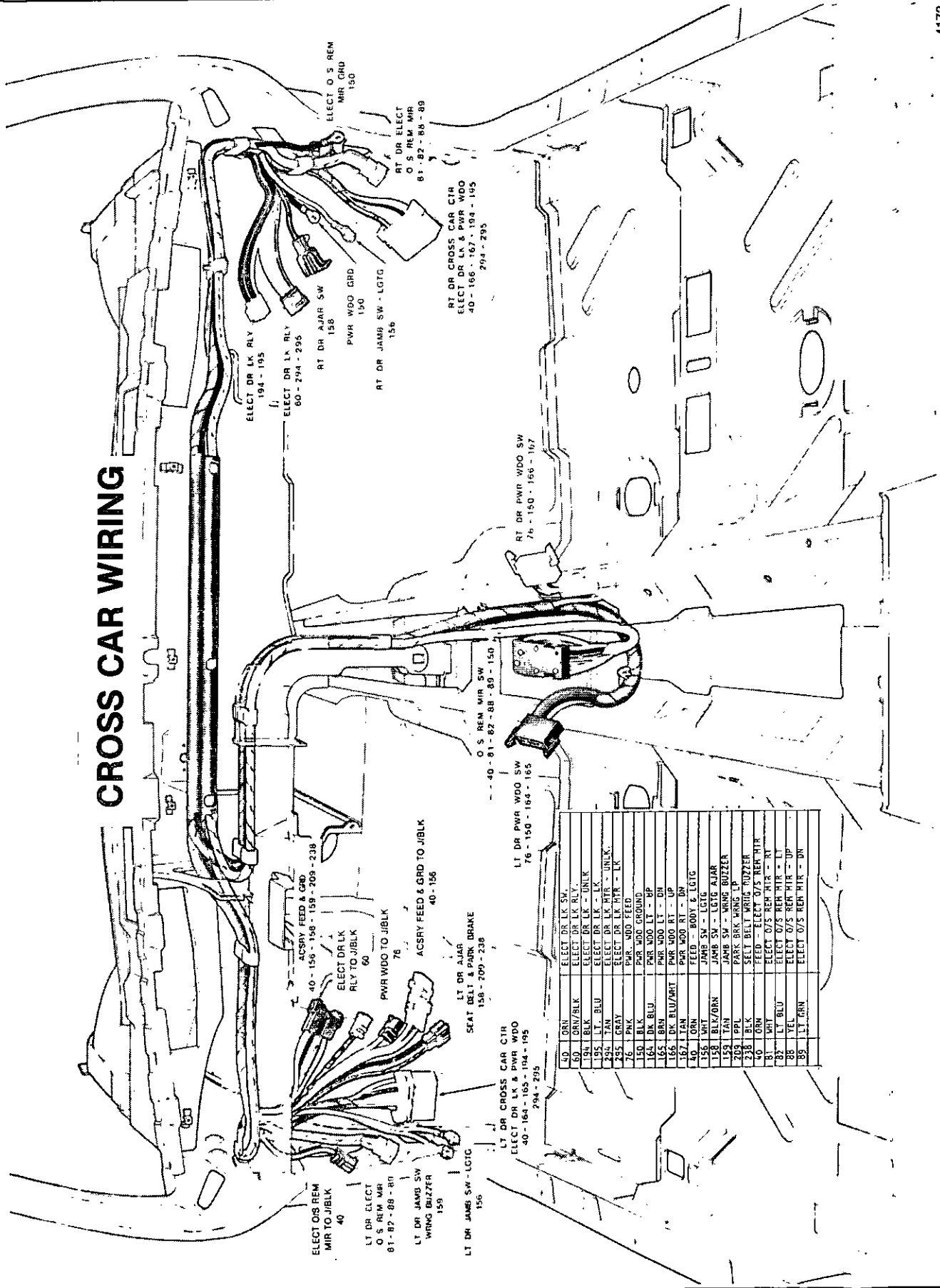

40	ORN	ELECT DR LK SW.
60	ORN/BLK	ELECT DR LK RLY.
194	BLK	ELECT DR LK - UNLK
195	LT - BLU	ELECT DR LK - LK
234	TAN	ELECT DR LK MTR - UNLK.
235	GRAY	ELECT DR LK MTR - LK
76	PKK	PWR. WDO FEED
150	BLK	PWR. WDO GROUND
164	DK BLU	PWR WDO LT - RP
165	BRN	PWR WDO LT - DN
166	DK BLU/WHI	PWR WDO RT - UP
167	TAN	PWR WDO RT - DN
40	ORN	FEED - BODY & LGTGT
156	WHI	JAMB SW - LGTGT AJAR
158	BLK/ORN	JAMB SW - VMB BUZZER
162	TAN	SEAT BELT MTR - UP
163	PKL	SEAT BELT MTR - DN
234	BLK	FEED - ELECT O/S REM MHR
80	WHY	ELECT O/S REM MHR - RT
83	LT BLU	ELECT O/S REM MHR - LT
88	VEL	ELECT O/S REM MHR - UP
89	LT GRN	ELECT O/S REM MHR - DN

Fig. 10-5-Cross Car Wiring

# CENTER CONSOLE WIRING

46	DK BLU	FEED - IN SEAT S/SPKR - RT
199	BRN	FEED - IN SEAT S/SPKR - LT
115	LT BLU	RTN - IN SEAT S/SPKR - RT
116	YEL	RTN - IN SEAT S/SPKR - LT
40	ORN	FEED - ELECT O/S REM MIR
81	WHT	ELECT O/S REM MIR - RT
82	LT BLU	ELECT O/S REM MIR - LT
88	YEL	ELECT O/S REM MIR - UP
89	LT BRN	ELECT O/S REM MIR - DN
76	PNK	FEED - PWR WDO
150	BLK	GROUND - PWR WDO
164	DK BLU	PWR WDO LT - UP
165	BRN	PWR WDO LT - DN
166	DK BLU/WHT	PWR WDO RT - UP
167	TAN	PWR WDO RT - DN

O/S REM MIR SW  
40 - 81 - 82 - 88  
89 - 150

LT DR PWR WDO SW  
76 - 150 - 164 - 165

RT DR PWR WDO SW  
76 - 150 - 166 - 167

TO RADIO  
46 - 115  
116 - 199

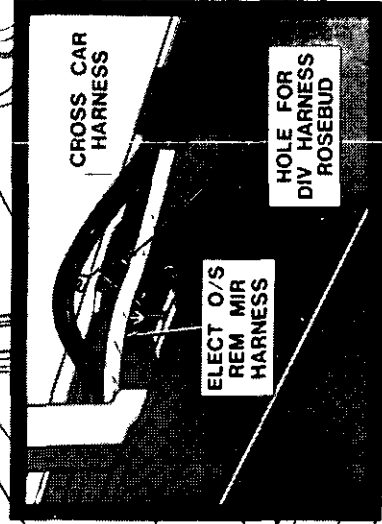

PASSENGER  
IN SEAT STEREO  
SPKR ASM  
46 - 115 - 116 - 199

PASSENGER SIDE OF  
SPEAKER HARNESS IS  
THE LONG LEAD

DRIVER  
IN SEAT STEREO  
SPKR ASM  
46 - 115 - 116 - 199

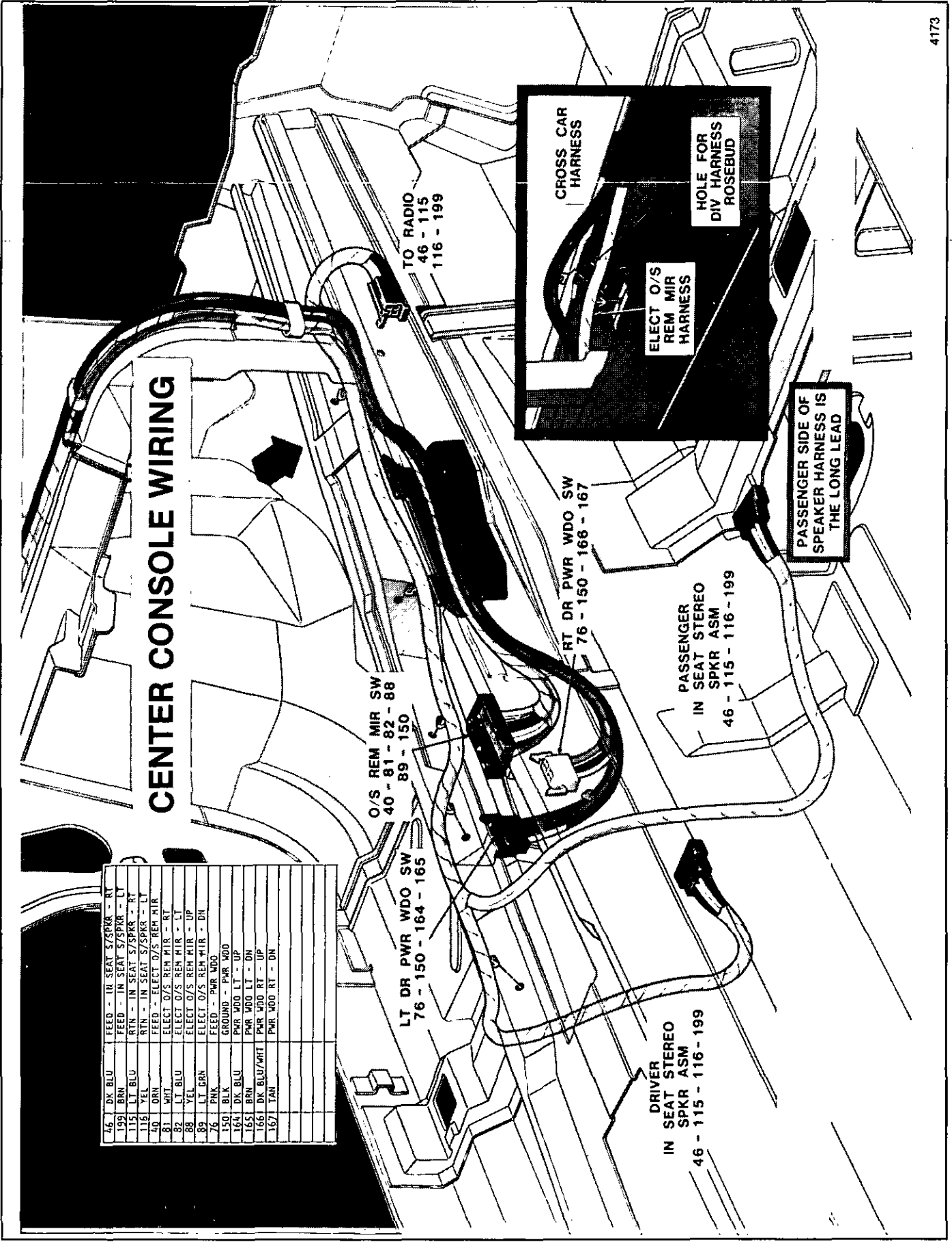



# PASSENGER COMPARTMENT WIRING — RIGHT

RT DR AJAR SW  
158

40	DRN	FEED - ELECT DR LK SW
50	DRN/BLK	FEED - ELECT DR LK RLY
194	BLK	ELECT DR LK - UNLK
195	LT BLU	ELECT DR LK - LK
294	TAN	ELECT DR LK MTR - UNLK
295	GRAY	ELECT DR LK MTR - LK
150	BLK	GROUND - PWR WDO
156	DR BLU/WHI	PWR WDO RT - DP
154	TAN	PWR RT - DN
158	BLK/ORN	JAMB SW - LGTG AJAR
150	BLK	GROUND - ELECT O/S REM MTR
81	WHT	ELECT O/S REM MTR - RT
82	LT BLU	ELECT O/S REM MTR - LT
88	YEL	ELECT O/S REM MTR - DP
89	LT GRN	ELECT O/S REM MTR - DN

ELECT DR LK RLY  
60 - 294 - 295

ELECT DR LK RLY  
194 - 195

PWR WDO GRD  
150

ELECT O/S REM MTR GRD  
150

USE GROUND SCREW  
22508732  
(DO NOT SUBSTITUTE)

RT DR JAMB SW - LGTG  
156

RT DR  
ELECT O/S REM MTR  
81 - 82 - 88 - 89

RT DR AJAR SW  
158

RT DR CROSS CAR CTR  
ELECT DR LK & PWR WDO  
40 - 166 - 187 - 194  
195 - 294 - 295

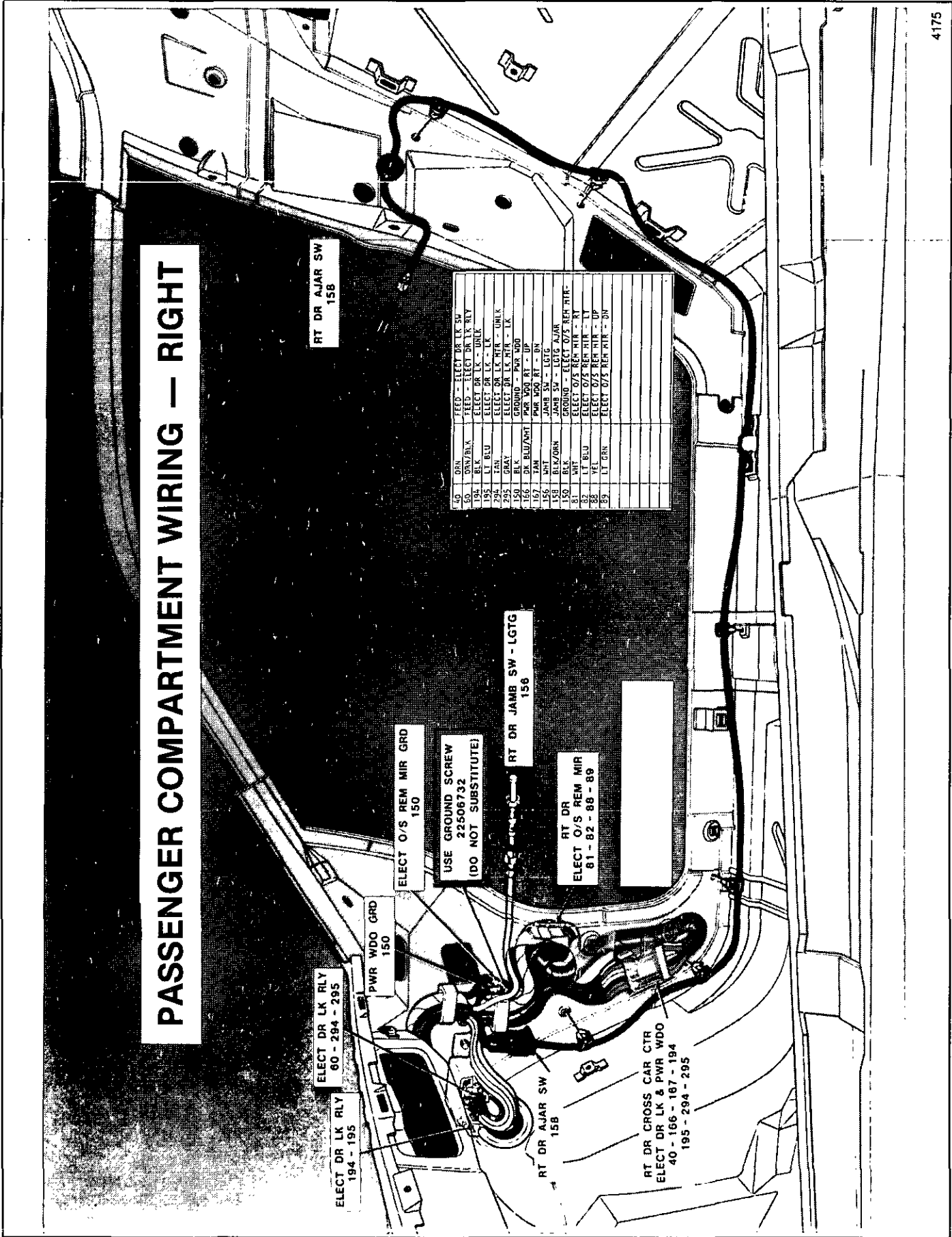



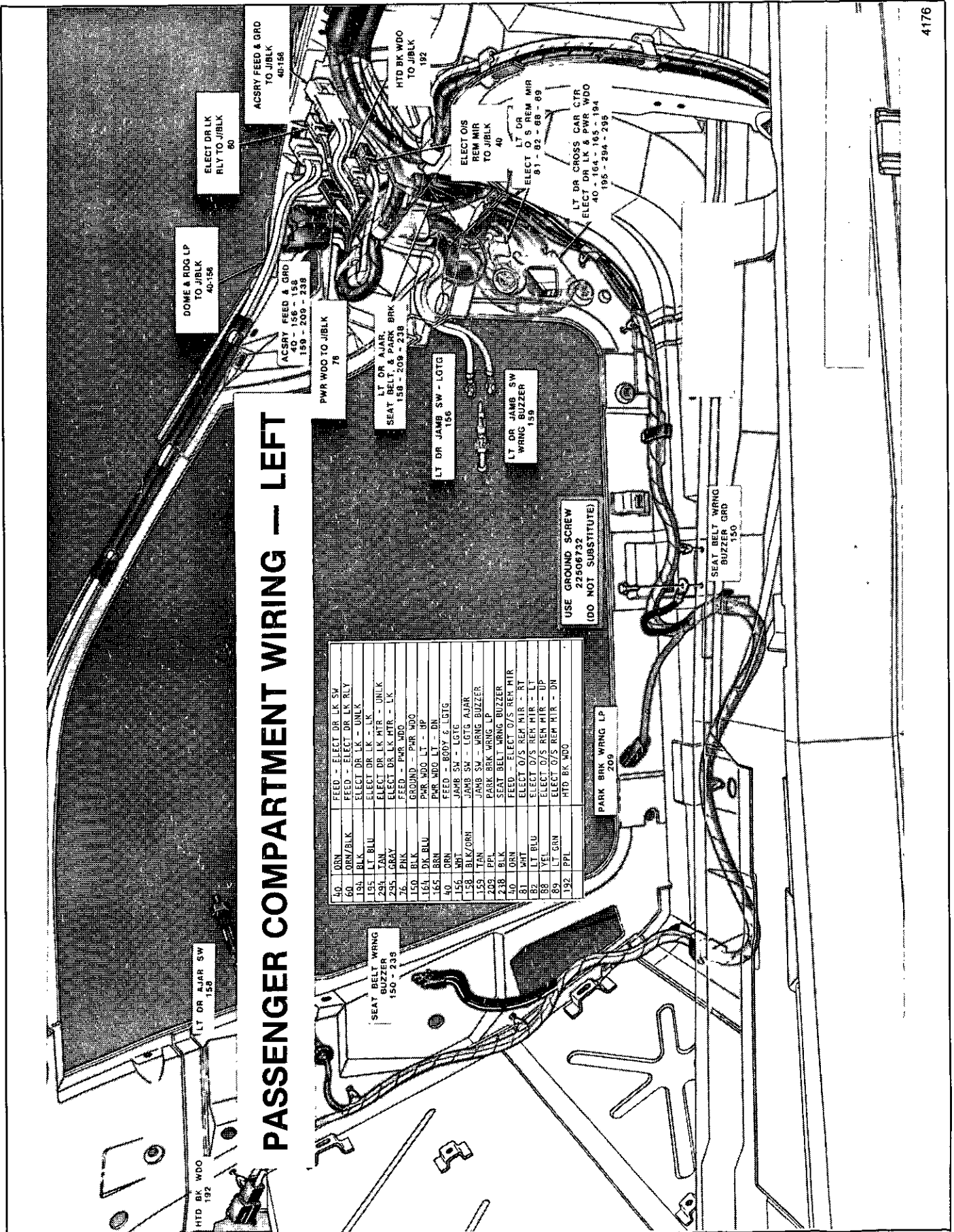
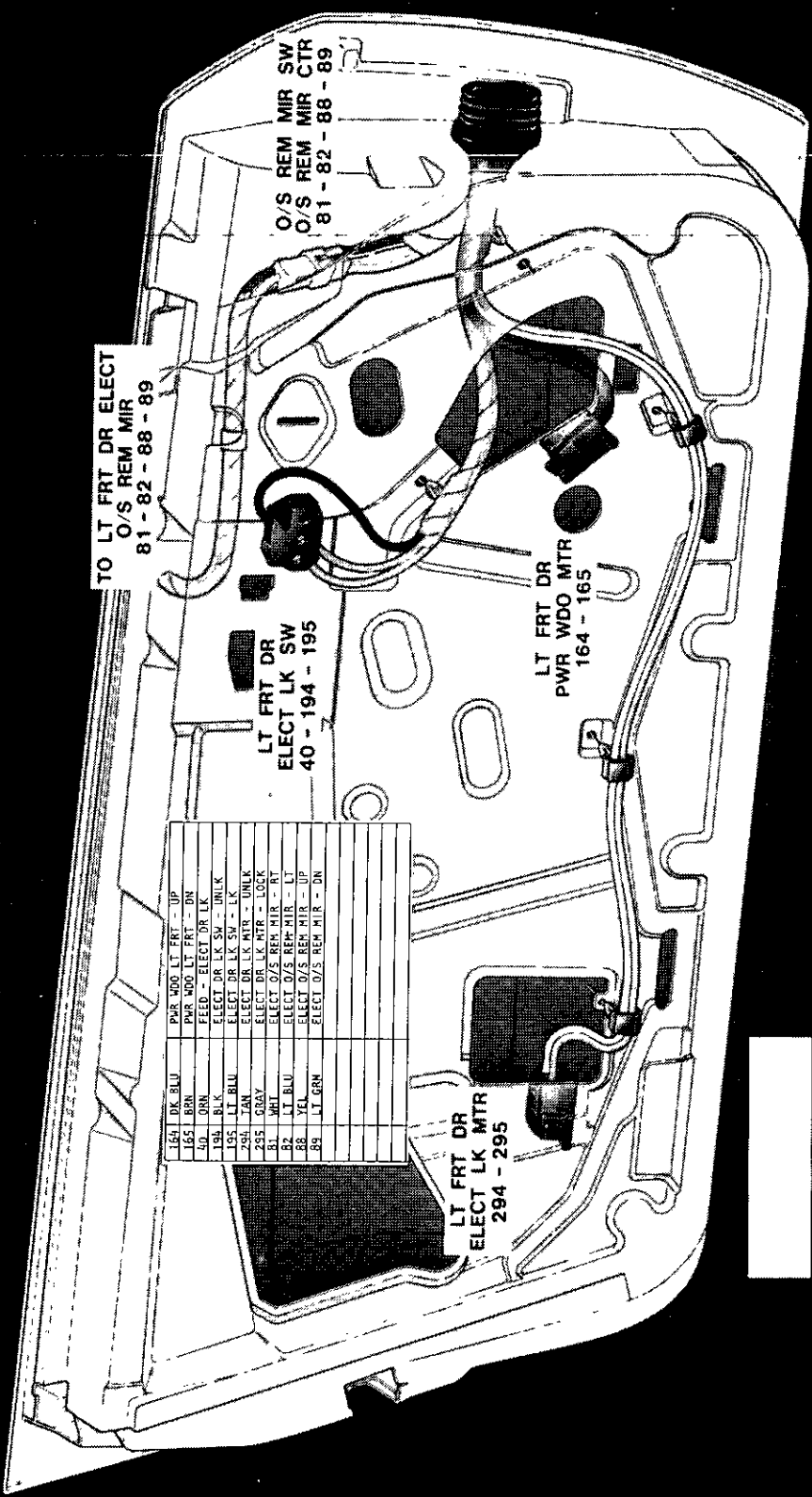

Fig. 10-9-Passenger Compartment Wiring - Left

# FRONT DOOR WIRING — LEFT



164	DRK	BLU	PWR	160	LT	FRT	-	UP
165	GRN		PWR	160	LT	FRT	-	DN
40	GRN		ELECT					DR
184	BLK		ELECT					DR
194	BLK		ELECT					DR
195	LT	BLU	ELECT					DR
294	TAN		ELECT					DR
295	GRAY		ELECT					DR
81	WHT		ELECT					O/S
82	LT	BLU	ELECT					O/S
88	YEL		ELECT					O/S
89	LT	GRN	ELECT					O/S

# SHROUD WIRING DETAIL — RIGHT

140	ORN	FEED - ELECT DR LK SW
141	ORN/BLK	FEED - ELECT DR LK RLY
142	BLK	ELECT DR LK - UNLK
143	LT. BLU	ELECT DR LK - LK
144	JAN	ELECT DR LK RIR - UNLK
145	GRY	ELECT DR LK RIR - LK
146	DK. BLU/WHI	GROUND - PWR WDO
147	TAN	PWR WDO RT - DN
148	WHI	JAMB SW - LGTG
149	BLK/ORN	JAMB SW - LGTG AJAR
150	BLK	GROUND - ELECT O/S REM MIR
151	WHI	ELECT O/S REM MIR - RT
152	LT. BLU	ELECT O/S REM MIR - LT
153	VEL	ELECT O/S REM MIR - DN
154	LT. GRN	ELECT O/S REM MIR - DN

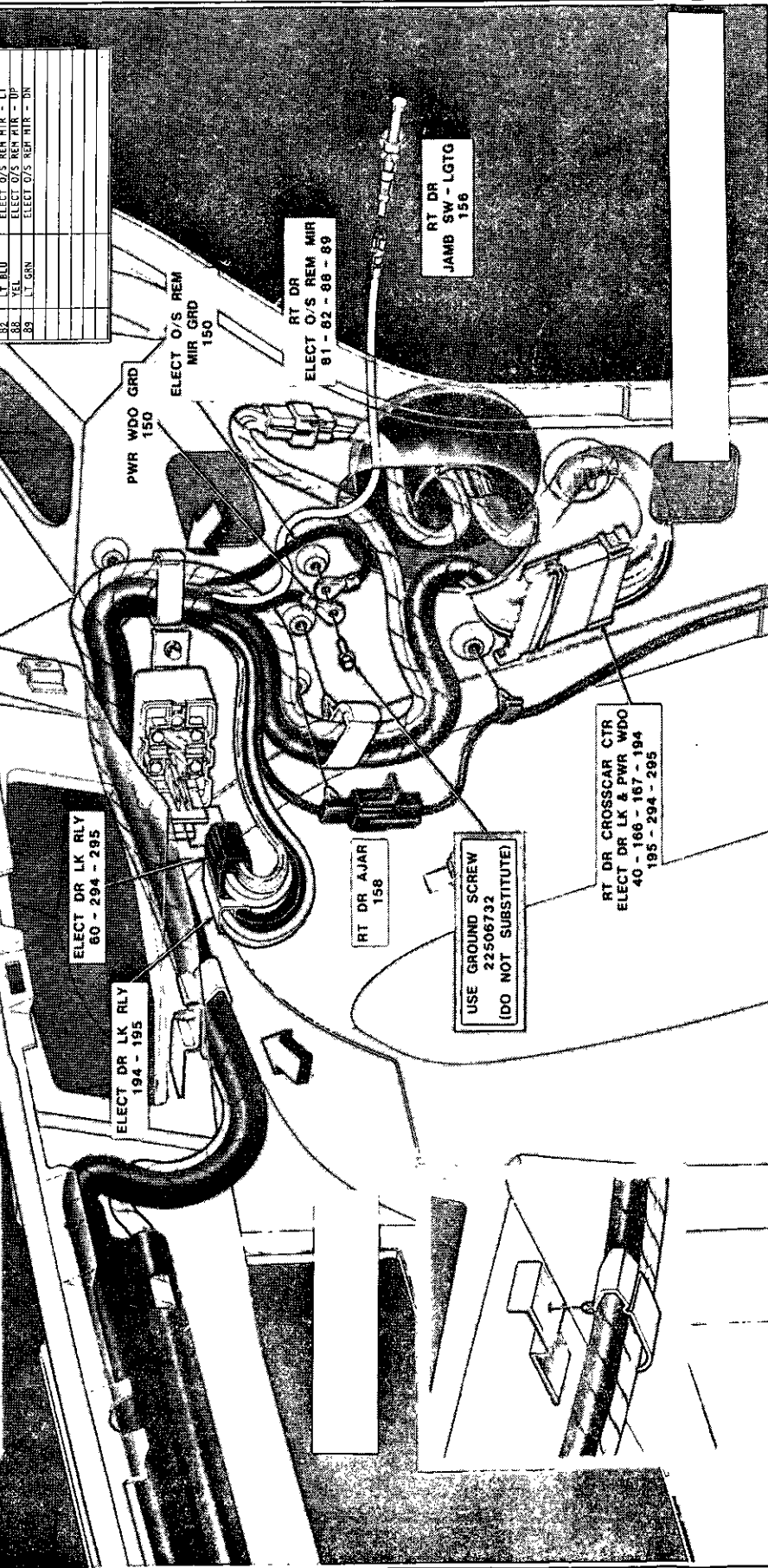
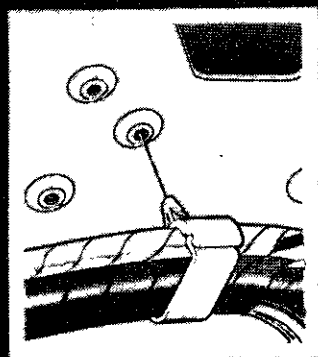

Fig. 10-11 Shroud Wiring - Right

# SHROUD WIRING DETAIL -- LEFT

40	ORN	FEED - ELECT DR LK SW
40	ORN/BLK	FEED - ELECT DR LK BLV
158	BLK	ELECT DR LK - UNLK
158	LT BLU	ELECT DR LK - LK
294	TAN	ELECT DR LK MTR - UNLK
295	GRAY	ELECT DR LK MTR - LK
76	PHK	FEED - PWR WDO
150	BLK	GROUND - PWR WDO
164	DR BLU	PWR WDO LT - UP
165	DR	PWR WDO LT - DN
166	DR	PWR WDO LTG LGT
167	DR	JAMB SW - LGT LGT
158	BLK/ORN	JAMB SW - LGT LGT
158	TAN	JAMB SW - WRNG BUZZER
209	PPL	PARK BRK WRNG LP
238	BLK	SEAT BELT WRNG BUZZER
50	ORN	FEED - ELECT O/S REM MIR
81	WHT	ELECT - O/S REM MIR - RT
82	LT BLU	ELECT - O/S REM MIR - LT
88	YEL	ELECT - O/S REM MIR - UP
89	LT GRN	ELECT - O/S REM MIR - DN
192	PPL	HID BK LPO

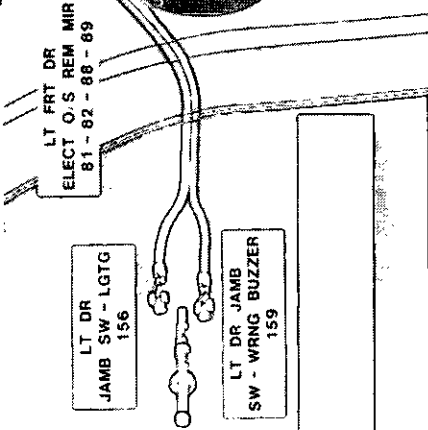
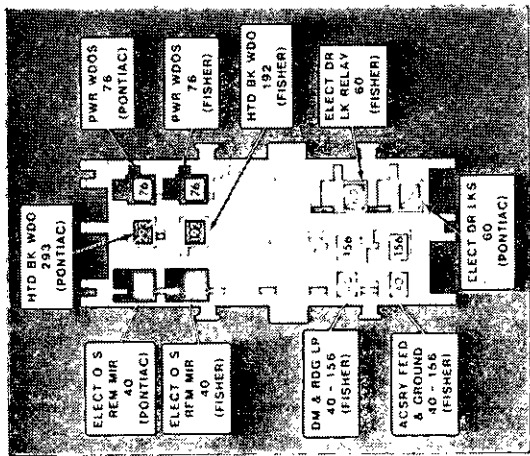
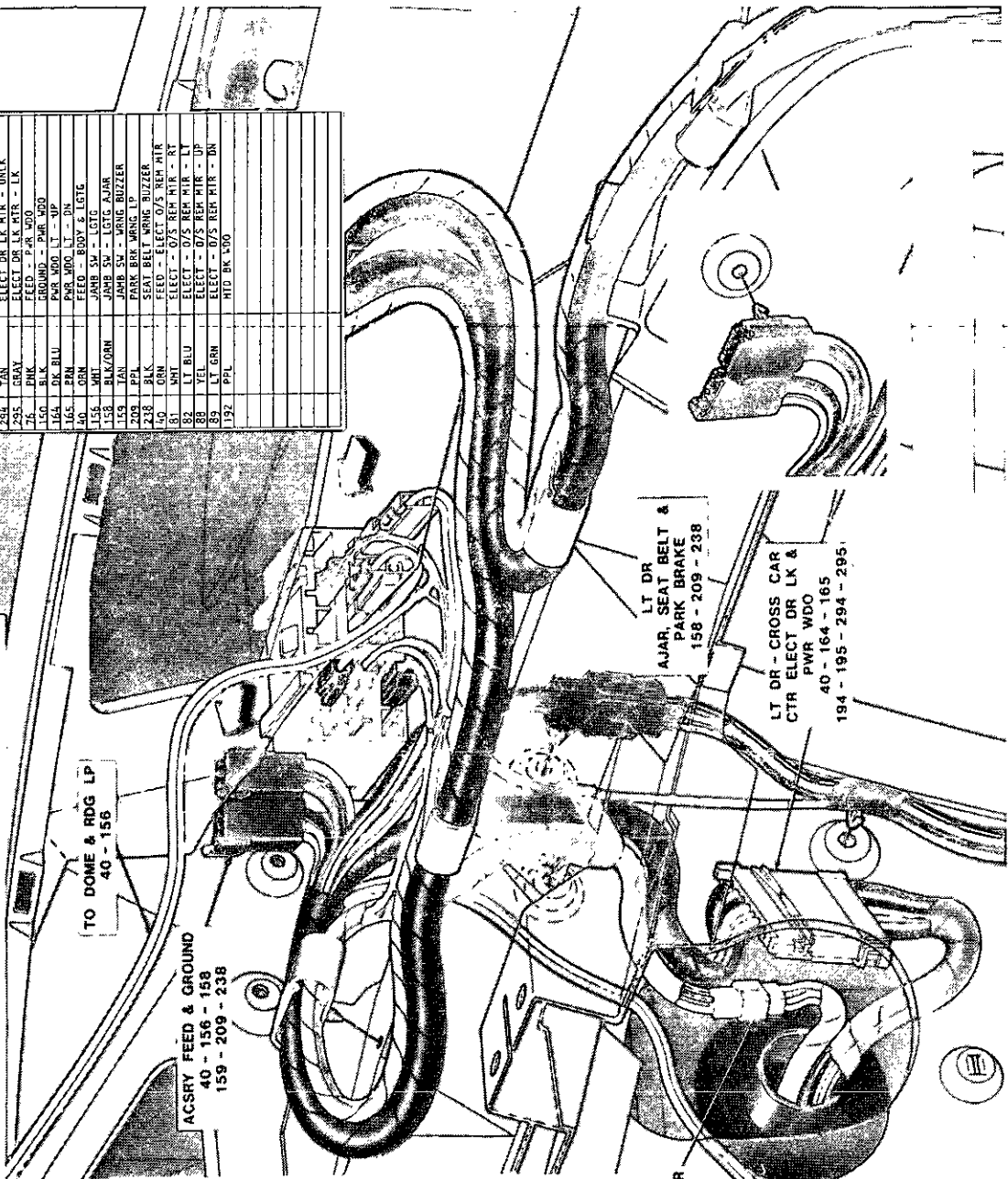
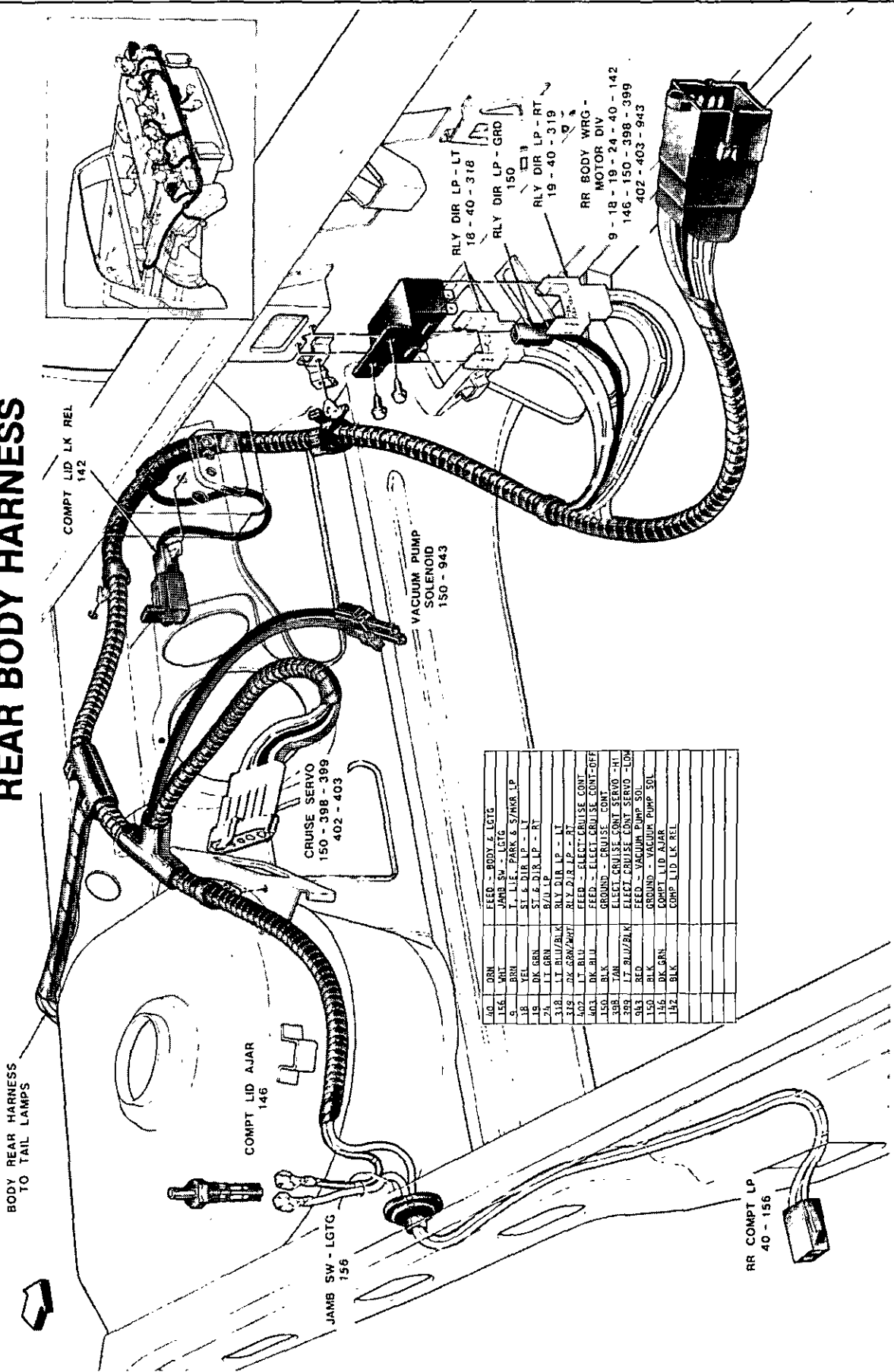

Fig. 10-12 Shroud Wiring - Left

# MOTOR COMPARTMENT PORTION OF REAR BODY HARNESS



110	ORN	FEED - BODY E LGTG
114	WHT	JAMB SW LGTG
9	BRN	T LLE - PARK & WASH LP
18	YEL	ST & DIR LP - LY
19	DK GRN	ST & DIR LP - RT
24	LT GRN	R/L LP
318	LT BLU/BLK	RLY DIR LP - LT
319	DK GRN/WHT	RLY DIR LP - RT
402	LT BLU	FEED - ELECT CRUISE CONT
403	DK BLU	FEED - ELECT CRUISE CONT-OFF
150	BLK	GROUND - CRUISE CONT
398	YAN	ELECT CRUISE CONT SERVO -HI
399	LT BLU/BLK	ELECT CRUISE CONT SERVO -LO
583	RED	FEED - VACUUM PUMP SOL
150	BLK	GROUND - VACUUM PUMP SOL
146	DK GRN	COMPT LID AJAR
142	BLK	COMPT LID LK REL

Fig. 10-13 Motor Compartment Portion of Rear Body Harness

**REAR END WIRING**

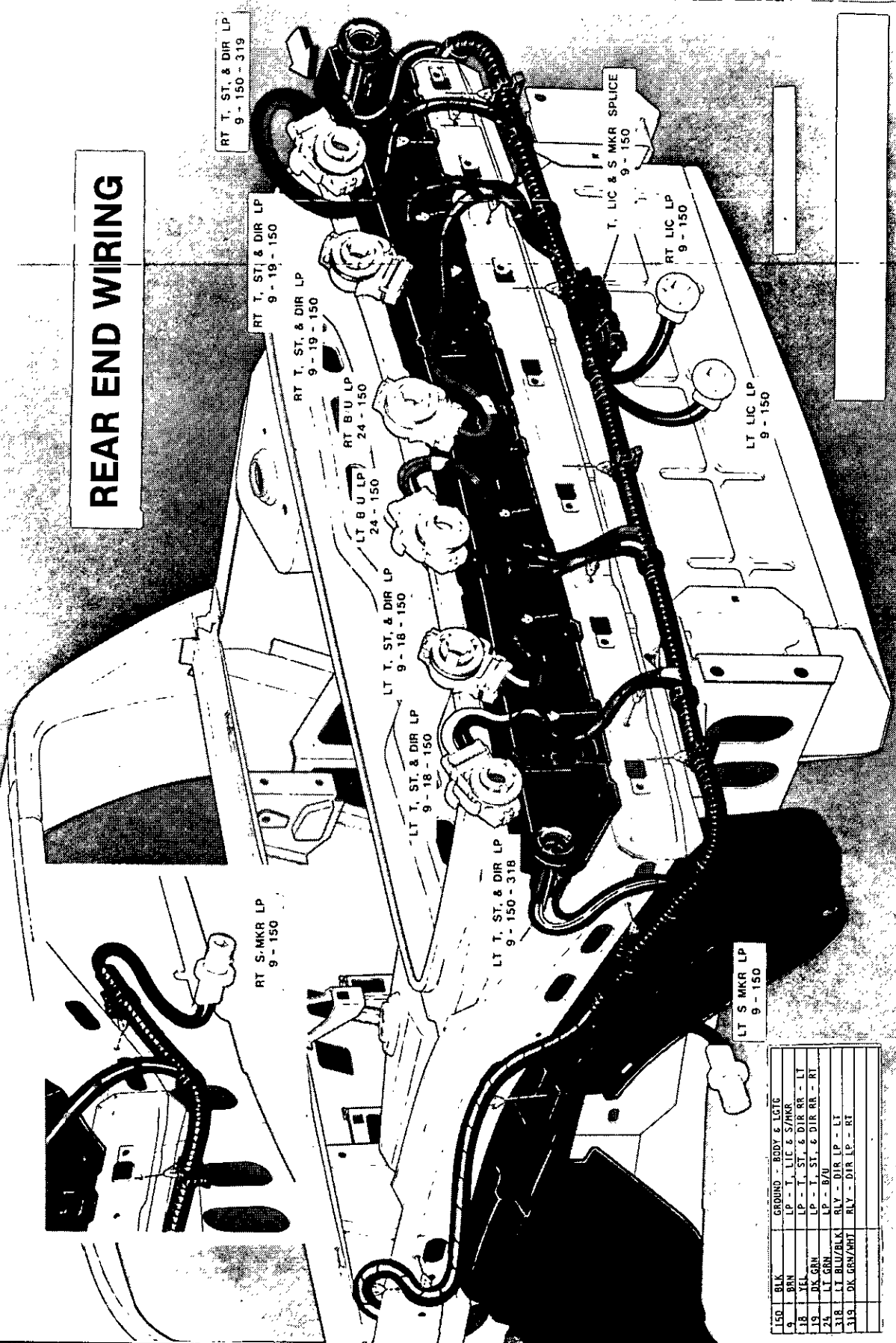

150	BLK	GROUND - BODY & LGTC
9	BRN	LP - T, LIC & S/MKR
18	YEL	LP - T, ST, & DIR RR - LT
19	DK GRN	LP - T, ST, & DIR RR - RT
24	LT GRN	LP - B/U
318	LT BLU/BLK	RLY - DIR LP - LT
319	DK GRN/WHT	RLY - DIR LP - RT

Fig 10-14 Rear End Wiring

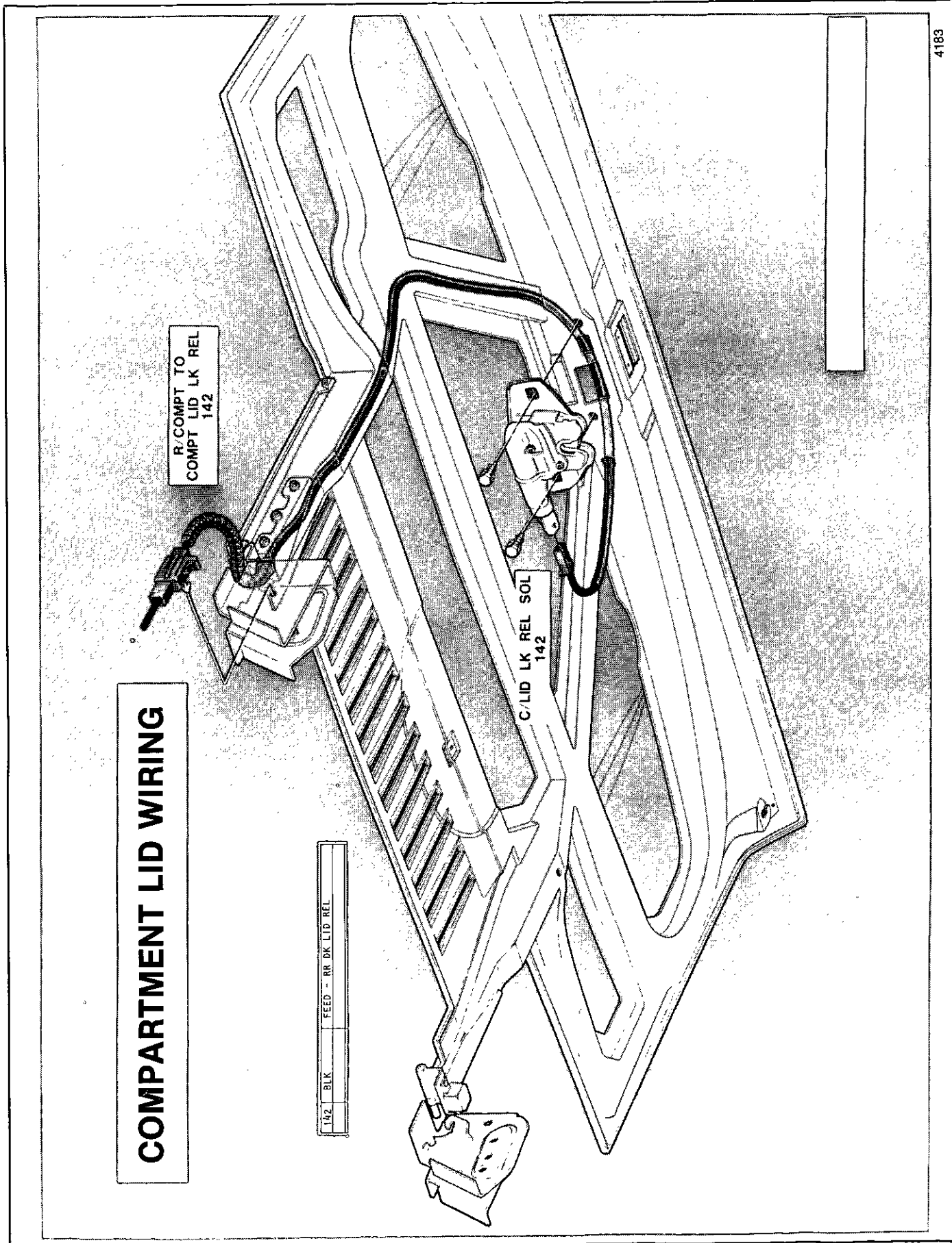

Fig. 10-15 Compartment Lid Wiring

**CIRCUIT ABBREVIATIONS**

<b>ABBREVIATION</b>	<b>COMPLETE NAME</b>
ACSRY	Accessory
ASM	Assembly
ASSY	Assembly
BK	Back
BRK	Brake
CTR	Center
DN	Down
DR	Door
ELECT	Electric
GRD	Ground
HTD	Heated
J/Block	Junction Block
LGTG	Lighting
LK	Lock
LP	Lamp
LT	Left
MIR	Mirror
MTR	Motor
PWR	Power
RDG	Reading
REM	Remote
RLY	Relay
RT	Right
RTN	Return
S/SPKR	Stereo Speaker
SW	Switch
WDO	Window
WRNG	Warning

3801

Fig. 10-16 Glossary of Circuit Abbreviations



# SECTION 11

## STATIONARY GLASS

### CONTENTS

<p>Removal of Minor Scratches and Abrasions ..... 11-1</p> <p>Windshield and Back Glass Reveal Moldings ..... 11-2</p> <p>Stationary Glass ..... 11-2</p> <p>Adhesive Service Kit ..... 11-2</p>	<p>Windshield ..... 11-3</p> <p>Back Glass ..... 11-4</p> <p>Short Installation Method ..... 11-4</p> <p>Extended Installation Method ..... 11-5</p> <p>Waterleak Correction ..... 11-5</p> <p>Bonded Rearview Mirror Support ..... 11-5</p>
--	--

#### REMOVAL OF MINOR SCRATCHES AND ABRASIONS

Minor glass scratches and abrasions on the outside surface of the glass can be removed or reduced by using the methods described in this section.

There are two basic types of auto glass: laminated safety plate (used in all windshields) and solid tempered safety plate (used in side and back windows).

A major concern in glass polishing is the chance of causing double vision in areas of occupant vision. For this reason, removal of scratches or abrasions on a windshield in the occupant's line of vision is more limited than in other areas. Distortion is most apt to result when trying to remove deep scratches. Scratch removal must be performed with care.

##### Tools Required:

- Low speed (600-1300 RPM) rotary polisher (Skil Model No. 570 or equivalent).
- Wool felt rotary-type polishing pad, about 75 mm (3") in diameter and 50 mm (2") thick.
- Powdered cerium oxide (No. 14 Rareox or equivalent) mixed with water as the abrasive compound. Follow manufacturer's directions when using any type of polishing compound.
- Wide mouth container to hold the polish.

**NOTICE:** This operation must not be used on the inside of rear window glass which has heating elements in the glass because the heating elements will be damaged.

1. Mix two parts of polishing compound (No. 14 Rareox or equivalent) with one part water to obtain a creamy mixture.
2. Stir mixture now and then to maintain a creamy texture. Powdered cerium oxide is hard to mix with water and tends to separate.
3. Draw a circle around the scratches on the opposite side of glass with a wax marking pencil or crayon. Draw other lines directly behind scratches to serve as guides in locating scratch during polishing (Fig. 1).
4. Use masking paper where needed to catch drippings or spattered polish.
5. Dip felt pad attached to polisher into mixture several times to insure that pad is well saturated.

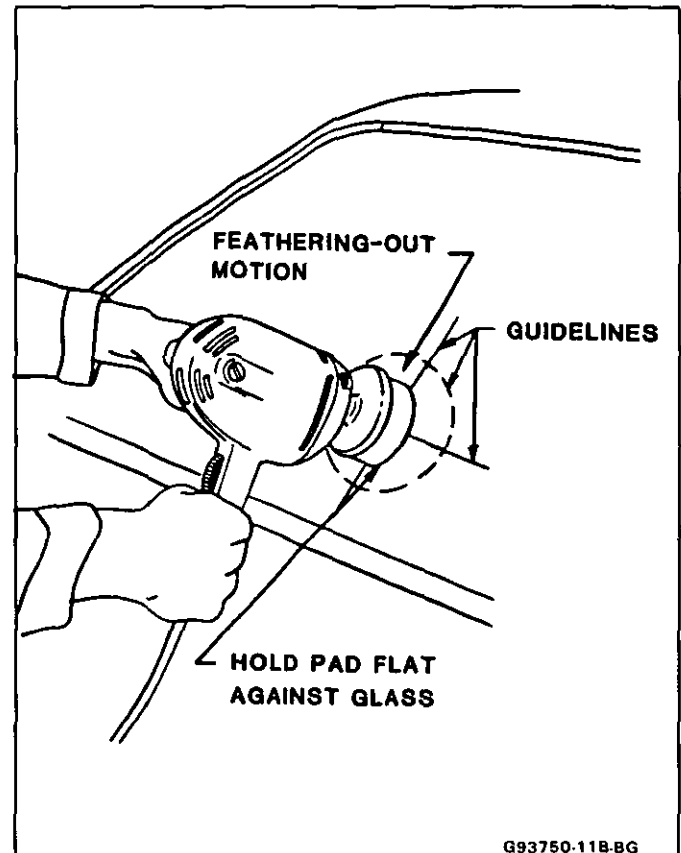

Fig. 1-Removing Minor Glass Scratches

6. Do not submerge or allow pad to stay in mixture as it may loosen bond between pad and metal plate.
6. Using moderate, but steady, pressure, hold pad flat against scratched area of glass, and with a feathering-out motion, polish affected area as shown in Figure 1. Avoid heavy pressure. It does not speed up operation and may cause overheating of glass.
7. Cover enough area around scratch with a feathering-out motion to eliminate any chance of a bull's-eye.

Do not hold tool in one spot or operate tool on the glass any longer than 30 to 45 seconds at a time. If glass becomes hot to touch, let it air cool before proceeding further. Cooling with cold water may crack heated glass.

## 11-2 STATIONARY GLASS

8. Dip pad into mixture frequently to insure that wheel and glass are always wet during polishing operation. A dry pad causes too much heat to build up.
9. After removing scratch or abrasion, wash glass with water and wipe body clean of any polish.
10. Clean polishing pad.

Care should be taken during polishing and storage to keep pad free of foreign material such as dirt, metal filings, etc.

### WINDSHIELD AND BACK GLASS REVEAL MOLDINGS

#### Vinyl Reveal Moldings

The reveal molding is a vinyl trim that fills the cavity between the body and glass edge. The reveal molding is hand pressed into place and is retained by urethane adhesive.

#### ↔ Remove or Disconnect

1. With a flat-bladed tool, carefully pry end of molding out about 75 mm (3").
2. Grasp with hand and slowly pull molding away from body.

#### →← Install or Connect (Figs. 2, 3, 4)

1. To reuse original reveal molding, trim off barb and prefit in cavity (Fig. 2).
2. Apply clear primer from urethane kit (part no. 9636067 or equivalent) to lower surface of molding (1 or 4).

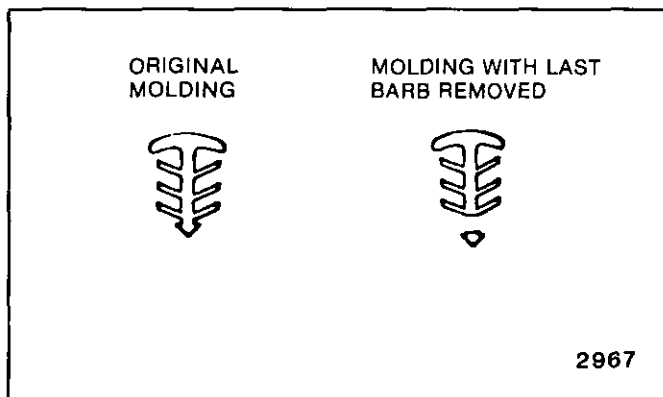

Fig. 2 - Removing Reveal Molding Barb

3. Apply urethane (2) in cavity between body and glass.
4. Flood cavity with warm water to speed set-up of adhesive.
5. Start from center and hand press molding into place.
6. Tape can be applied to keep reveal molding flush with body.
7. Flood molding with warm water.

### STATIONARY GLASS

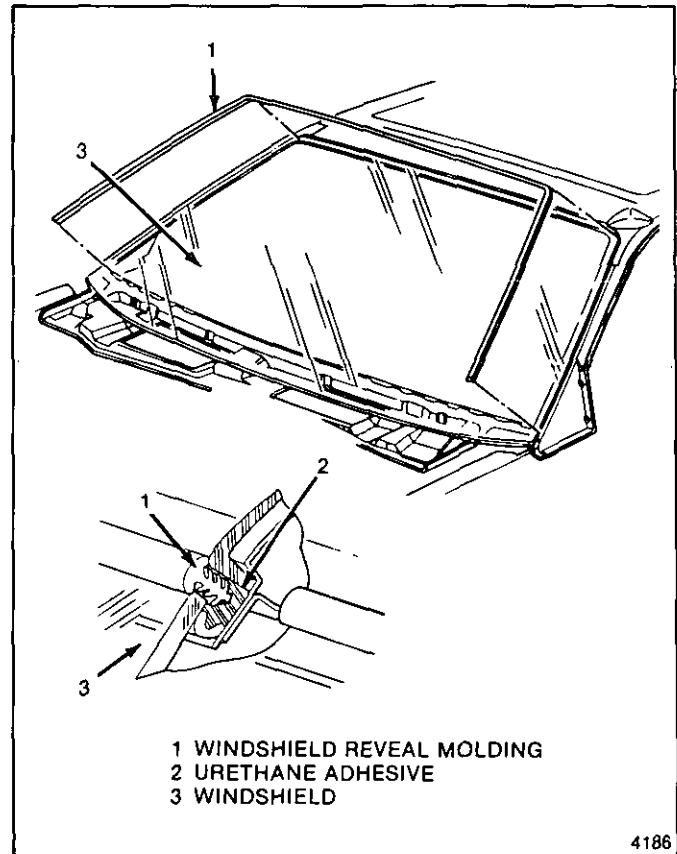

Fig. 3 - Installing Windshield Reveal Molding

replacement of material is referred to as the short method. Complete material replacement is known as the extended method.

The short method can be used where original adhesive left on window opening pinchweld flanges after glass removal can serve as a base for the new glass. This method would apply in cases of cracked windshields or removal of windows that are still intact. The amount of adhesive left in window opening can be controlled during glass removal.

The extended method is to be used when the original adhesive left in window opening after glass removal cannot serve as a base for new glass. This method would be used in cases needing metal work or paint repair in the opening. In these cases, original material is removed and replaced with new material during window installation.

#### ADHESIVE SERVICE KIT

Adhesive Kit No. 9636067 (urethane adhesive) or equivalent contains some of the items needed to replace a urethane adhesive installed glass using the short method or any adhesive installed glass using the extended method.

Additional items required:

- Solvent for cleaning edge of glass (preferably alcohol) and a household cartridge type caulking gun
- Commercial type razor knife (for cutting around edge of glass)

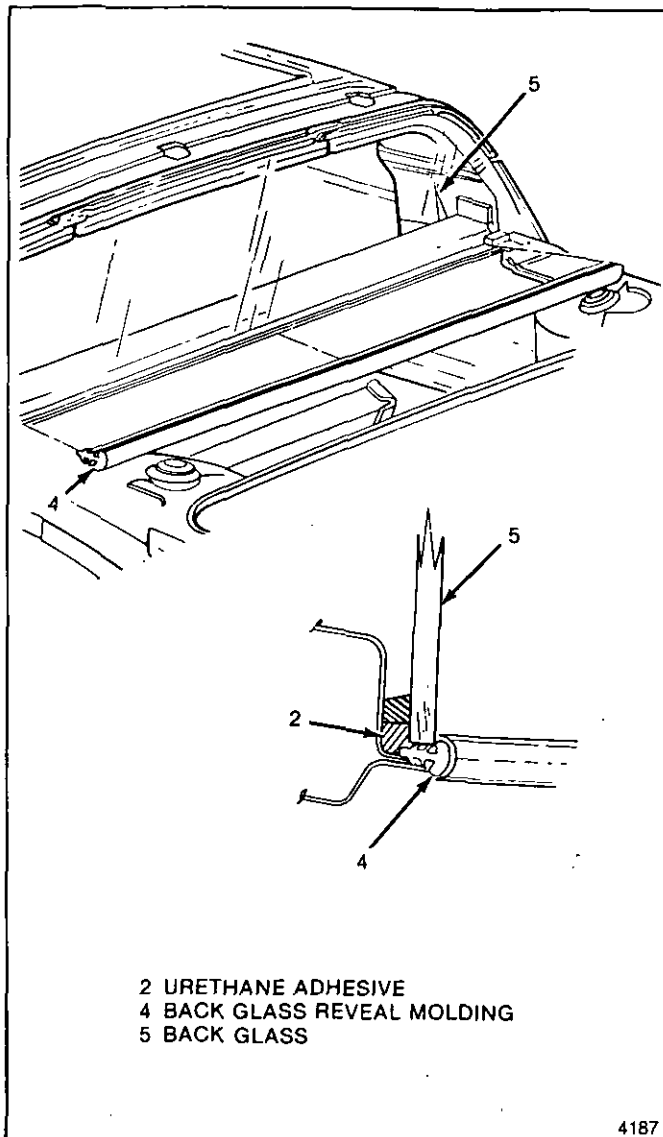

Fig. 4 - Installing Back Glass Reveal Molding

- Lower support spacers - for short and extended method installations (see service parts manual)

## WINDSHIELD

**NOTICE:** Place protective covers on body and mask off work area. Do not use a hot knife during cutout. It can cause heat damage.

### ↔ Remove or Disconnect (Figure 5)

1. Windshield wiper arm assemblies (refer to Section 8E in the chassis portion of this manual).
2. Shroud top vent screen (refer to Section 4 in the body portion of this manual).
3. Reveal molding
4. Two roof panel to cowl panel attaching screws (Section 8)
5. Fender to side rail attaching bolts (Section 4). Pull fender down from top to gain clearance for windshield removal.

6. Make a preliminary cut into urethane around perimeter of glass (3) with a razor knife. Cut as close to glass as possible.
7. Cut out glass with tool J-24402A (or equivalent) and remove.

### ↔ Install or Connect (Figure 5)

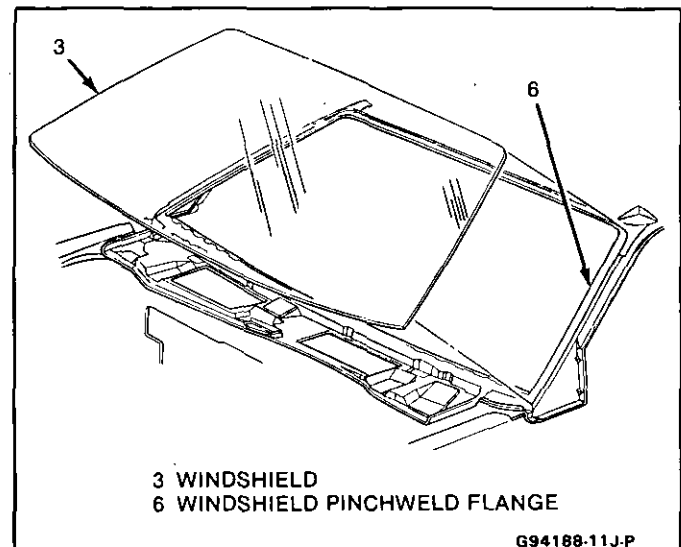

Fig. 5-Installing Windshield

1. With old glass as a guide, apply foam sealing strip to glass. Make sure sealing strip does not obstruct view of VIN from outside.
2. Use suction cups on glass and with a helper prefit glass to maintain proper clearance between pinchweld flanges (6) and glass edge.
3. Remove glass (3).
4. Refer to applicable installation method.
5. Position glass (3) and apply hand pressure to wetout and set adhesive. Remove suction cups.
6. Paddle adhesive around edge of glass with a brush or flat bladed tool to ensure a watertight seal.

### ! Important

Watertest immediately, use a soft spray of warm or hot water. Do not direct a stream of water at wet adhesive. Work in additional adhesive as needed.

7. Reveal molding
8. Shroud top vent screen (refer to Section 4 of the body portion of this manual).
9. Windshield wiper arm assemblies. Refer to Section 8E in the chassis portion of this manual).

### 🧼 Clean

Remove tape and protective covers carefully. Use alcohol to clean adhesive.

10. Cowl panel and fender attaching bolts.
11. Let car sit for six hours at room temperature to complete cure of adhesive.

**BACK GLASS**

For back glass removal, the method is the same for both the short and extended installations with one exception. For the short method, care must be taken during cutout to make sure an even bead of adhesive remains on pinchweld flanges to serve as a base for the new glass.

**NOTICE:** Place protective covers on body. Mask off work area and heat elements (if equipped). Do not use a hot knife during cutout, it may cause heat damage to body.

**Tools Required:**

- Curved blade utility knife
- Piano wire

Refer to the appropriate body section for the following subassemblies.

**↔ Remove or Disconnect (Figure 6)**

1. Rear compartment lid (Section 7)
2. Rear compartment side cover panels
3. Rear compartment side cover grille extensions
4. Back window side filler panels
5. Dome lamp assembly
6. Sunshade assemblies
7. Upper garnish molding
8. Upper seat belt anchor assemblies
9. Rear quarter trim panels
10. Headlining
11. Rear console pad from shifter plate assembly
12. Seatback-to-motor compartment panel
13. Rear window defogger wire connector from back glass (if equipped)
14. Reveal molding
15. Glass stops
16. Cut through urethane bond around glass edge with a curved blade utility knife.
17. With the aid of a helper, pull piano wire around edge of glass (5), starting at the top (one person inside and one person outside the car).
18. Cut around lower corners with a curved blade utility knife and remove glass.

**↔ Install or Connect (Figure 6)**

1. Glass stops in original position
2. Suction cups to glass, and with a helper prefit glass to maintain proper clearance between pinchweld flanges and glass edge.
3. Remove glass (5)
4. Refer to applicable installation method
5. Position glass on glass stops and push at top. Remove suction cups and apply hand pressure to wet-out and set adhesive.

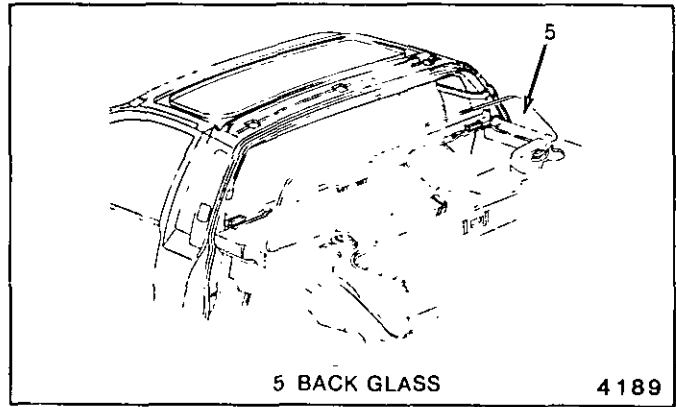

Fig. 6-Installing Back Glass

**! Important**

Watertest immediately, use a soft spray of warm or hot water. Do not direct a stream of water at wet adhesive. Work in additional adhesive as needed.

7. Reveal molding
8. Seatback-to-motor compartment panel
9. Rear console pad to shifter plate
10. Headlining
11. Rear quarter trim panels
12. Upper seat belt anchor assemblies

**⊞ Tighten**

Upper seat belt anchor bolts from 35 to 48 N·m (26 to 35 ft-lb)

13. Upper garnish molding
14. Sunshade assemblies
15. Dome lamp assembly
16. Rear compartment side cover grille extensions
17. Back window side filler panels
18. Rear compartment side cover panels
19. Rear compartment lid
20. Rear window defogger wire connector to back glass (if equipped)

**🧼 Clean**

Remove tape and protective coverings. Use alcohol to clean any spillage.

**Short Installation Method**

The short method is used on urethane installations only. Any prior service installation using butyl tape or other installations of unknown material must be replaced using the extended method.

**Prep and Sealing (Figure 7)**

1. Clean around edge and inside surface of glass with alcohol. Allow to air dry.
2. Apply clear primer to perimeter of glass edge and 7 mm (9/32") inboard on inner surface.
3. Apply black primer over clear primer on glass. Allow five minutes to dry.

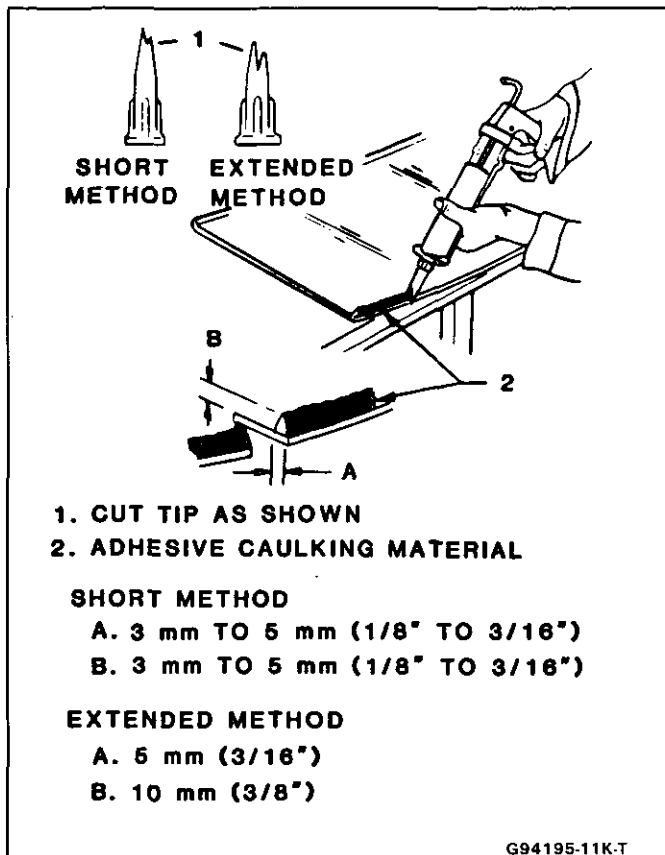

Fig. 7-Applying Adhesive Material

### Extended Installation Method

The extended method is necessary on butyl tape or urethane installation if after removal of glass, the urethane or butyl base is damaged or must be removed for metal or paint repair.

### Prep and Sealing (Figure 7)

1. Scrape or chisel old adhesive or butyl tape from pinchweld flanges. There should not be any mounds or loose pieces left.
2. Apply black primer to any exposed surface on pinchweld flanges. Allow five minutes to dry.
3. Enlarge nozzle furnished in kit as shown in (Figure 7).
4. Clean around edge and inside surface of glass with alcohol. Allow to air dry.
5. Apply clear primer to perimeter of glass edge and 7 mm (9/32") inboard on inner surface.
6. Apply black primer over clear primer on glass. Allow five minutes to dry.
7. Apply a smooth continuous bead of adhesive 10 mm (3/8") high by 5 mm (3/16") wide completely around inside edge of glass (Fig. 7). Tip bead of adhesive slightly inboard.

### WATERLEAK CORRECTION

Urethane glass installation waterleaks can be corrected without removing and reinstalling glass.

#### Tools Required:

Adhesive Kit No. 9636067 (or equivalent)

### Procedures (Figure 8)

1. Remove reveal molding
2. Push on glass in area of leak to determine the extent of leak and mark location. This operation should be performed while water is being applied to leak area.
3. From outside body, clean around leak area with water and dry with an air hose.
4. Cut away uneven edge of adhesive at leak point (7) and 75 mm (3") to 100 mm (4") on both sides.
5. Prime affected area (8) with black primer and allow five minutes to dry.

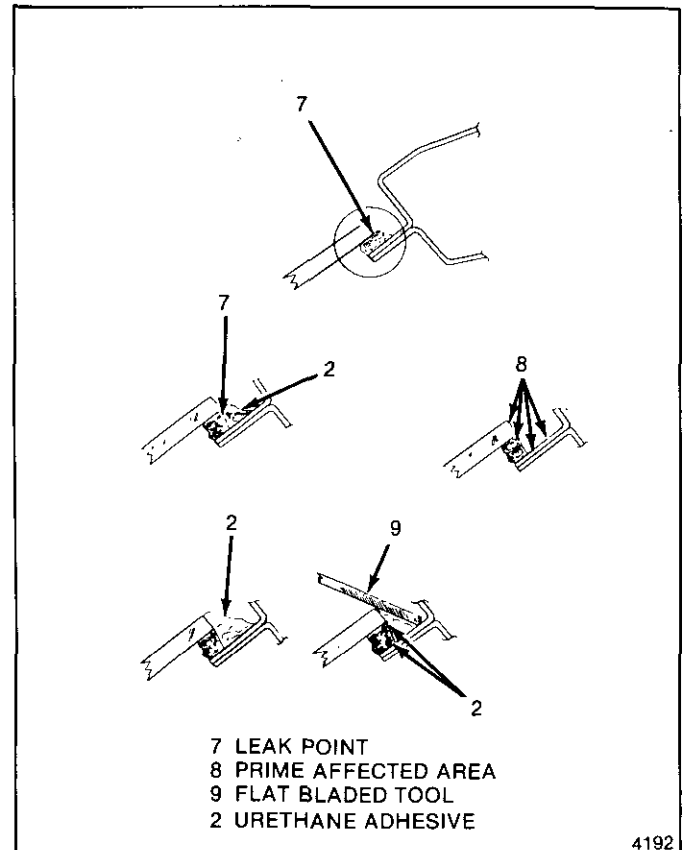

Fig. 8-Adhesive Glass Waterleak Correction

6. Use a flat bladed tool (9) to work adhesive (2) in and around leak point (7) to ensure a watertight seal.
7. Spray test leak area with warm or hot water. Do not apply a direct stream of water to fresh adhesive.
8. Install reveal molding.

### BONDED REARVIEW MIRROR SUPPORT

The rearview mirror is attached to a support which is secured to the windshield glass.

#### Tools Required:

- Part No. 1052369, Loctite Minute-Bond Adhesive 312 two component pack (or equivalent)
- Part No. 9831062, Rearview Mirror Support (or equivalent)

→← Install or Connect (Figure 9)

1. Locate support position at center of glass 114 mm (4-1/2") from top of glass to top of support (3).
2. Circle location on outside of glass with wax pencil or crayon. Draw a larger circle around support circle (2).
3. Clean the area within the large circle with household cleaner and dry. Repeat procedure with alcohol.
4. Sand bonding surface of support with fine grit (No. 320 or No. 360) emery cloth or sandpaper. If original support is reused, all traces of adhesive must be removed.
5. Wipe support clean with alcohol and air dry.
6. Apply adhesive as per kit instructions.
7. Position support to location with rounded end up.
8. Press against glass for 30 to 60 seconds. Excess adhesive can be cleaned off after five minutes with alcohol.

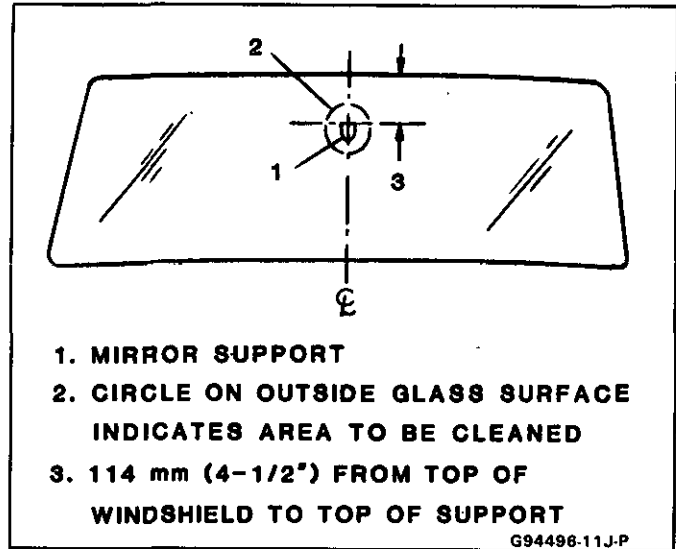

Fig. 9-Locating Bonded Rearview Mirror Support on Glass

# BODY INDEX

## A

- Adhesive Service Kit - Stationary Glass ..... 11-2
- Ajar Switch
  - Door ..... 5-18
  - Rear Compartment ..... 7-4
- Alignment Checking - Underbody ..... 3-1
- Anticorrosion Treatment ..... 1-3
- Applique Panel Assembly ..... 6-5
- Armrest and Pull Handle Assemblies ..... 5-1
- Assembling and Coding Lock Cylinder ..... 1-1

## B

- Back Glass Removal/Installation ..... 11-4
- Back Window Side Filler Panel ..... 6-2
- Back Window to Quarter Filler Panel ..... 6-2
- Body Repair ..... 1-6
- Body Ventilation ..... 4-1
- Bonded Rearview Mirror ..... 11-5
- Braided Wire Lead Repair - Defogger ..... 10-2

## C

- Carpets, Floor ..... 3-2
- Center High-Mounted Stop Lamp ..... 7-8
- Center Molding Assembly - Door
  - Exterior ..... 5-4
- Child Seat Top Strap Anchor ..... 9-2
- Circuit Abbreviations ..... 10-14
- Coding Lock Cylinders ..... 1-1
- Colors for Painting Interior Plastic
  - Parts ..... 1-11
- Connecting Rods and Locking Rods -
  - Door ..... 5-7
- Control Arm Knob, Seat Adjuster ..... 9-4
- Cutting Keys ..... 1-1

## D

- Deflector, Water
  - Door Inner Panel ..... 5-5
  - Plenum Chamber, Front End ..... 4-1
- Defogger - Rear Window ..... 10-1
- Diagnosis Chart - Manual Seat Adjuster ..... 9-7
- Dome Lamp Assembly ..... 8-3
- Doors
  - Ajar Switch ..... 5-18
  - Armrest and Pull Handle ..... 5-1
  - Bell Crank ..... 5-19
  - Connecting Rods and Locking Rods ..... 5-7
  - Exterior Moldings ..... 5-4
  - Glass Assembly ..... 5-14
  - Hardware Attachment Thread
    - Locking ..... 5-7
  - Hardware Lubrication ..... 5-7
  - Hinge System ..... 5-20
  - Inside Remote Handle ..... 5-7
  - Jamb Switch ..... 5-11
  - Lock Assembly ..... 5-18
  - Lock Knob and Remote Handle
    - Bezel ..... 5-2
  - Lock Striker ..... 5-9
  - Map Pocket ..... 5-4
  - Outer Door Panel Assembly ..... 5-7
  - Outside Handle ..... 5-7

- Outside Mirrors ..... 5-11
- Power Door Lock Systems ..... 5-18
- Sealing ..... 5-4
- Spring Clips ..... 5-7
- Trim Panel ..... 5-2
- Weatherstrips and Channels ..... 5-5
- Window Regulator Handle ..... 5-1

## E

- Extension - Rocker Panel Cover ..... 6-1
- Exterior Moldings
  - Doors ..... 5-4
  - Rear Quarters ..... 6-7
- Exterior Panel Identification ..... 1-6
- Exterior Panels
  - Doors ..... 5-7
  - Front Roof ..... 8-1
  - Rear Quarter ..... 6-7
  - Rear Roof ..... 6-9

## F

- Fender Panel ..... 4-4
- Finishing Lace - Vista Vent ..... 8-6
- Floor Carpets ..... 3-2
- Floor Pan Insulators ..... 3-1
- Front End
  - Fascia ..... 4-6
  - Fender Panel ..... 4-4
  - Front Wheelhouse Panel ..... 4-6
  - Grille Assembly ..... 4-6
  - Headlamp Door Assembly ..... 4-1
  - Hood Assembly ..... 4-3
  - Molding ..... 4-8
  - Sealing ..... 4-1
- Fuel Tank Filler Door
  - Door and Pocket Assembly ..... 6-7
  - Remote Latch and Cable Assembly ..... 6-7

## G

- General Body Construction and
  - Alignment ..... 3-1
- Glass Installation
  - Extended Method ..... 11-5
  - Short Method ..... 11-4
- Glass Roof Vent Storage Cover ..... 4-4
- Glass Scratch Removal ..... 11-1
- Grid Line Repair - Defogger ..... 10-1
- Grille ..... 4-6
- Grille, Speaker ..... 6-4

## H

- Handle
  - Door Inside Remote/Outside ..... 5-7
  - Window Regulator ..... 5-1
- Headlamp Door Assembly ..... 4-1
  - Cover Panel ..... 4-1
  - Filler Assembly ..... 4-3
  - Hinge Assembly ..... 4-3
- Headlining, Formed ..... 8-3
- Hinge
  - Door ..... 5-20
  - Hood ..... 4-3

## 2 BODY INDEX

Rear Compartment Lid .....	7-1
Hood Assembly .....	4-3
Ajar Switch .....	4-4
Alignment .....	4-3
Hinge .....	4-3
Latch .....	4-3
Striker .....	4-4
Horizontal and Vertical Underbody Dimensions .....	3-5

### I

Inner Door Window Belt Sealing Strip .....	5-4
Inner Panel Water Deflector - Door .....	5-5
Inside Remote Handle - Door .....	5-7
Insulators, Floor Pan .....	3-1
Interior Garnish Moldings	
Lower .....	3-2
Upper .....	8-4
Interior Plastic Trim and Parts Finishing .....	1-10

### J

Jamb Switch, Door .....	5-11
-------------------------	------

### K

Key Identification and Usage .....	1-1
------------------------------------	-----

### L

Lamps	
Center High-Mounted Stop Lamp .....	7-8
Dome .....	8-3
Tail .....	7-6
Lap and Shoulder Belts .....	9-1
Latch, Fuel Filler Door Remote .....	6-7
Lid, Rear Compartment .....	7-1
Lock Cylinder Assembly - Door .....	5-18
Lock Cylinder Coding .....	1-1
Locking Fuel Filler Door and Pocket Assembly .....	6-7
Lower Garnish Moldings .....	3-2
Lower Pressure Relief Valve .....	6-5
Lubrication .....	1-2
Door Hardware .....	5-7
Luggage Carrier Assembly .....	7-8

### M

Map Pocket .....	5-4
Mirrors	
Outside .....	5-11
Power Drive Unit .....	5-13
Rearview - Bonded Support .....	11-5
Moldings	
Exterior - Doors .....	5-4
Exterior - Front End .....	4-8
Exterior - Rear Quarters .....	6-7
Exterior - Roof Drip .....	8-4
Interior Garnish .....	3-2, 8-4
Reveal - Windshield and Back Glass .....	11-2
Roof Drip .....	8-4
Motor	
Window Regulator - Power .....	5-15

### O

### P

Painting of Exterior Panels .....	1-8
Painting Polypropylene Plastic Parts .....	1-10
Painting Rigid or Hard ABS Plastic Parts .....	1-10
Painting Vinyl and Flexible (soft) ABS Plastic Parts .....	1-11
Power	
Door Lock System .....	5-18
Mirror Drive Unit .....	5-13
Window Regulator .....	5-15
Pressure Relief Valve	
Lower .....	6-5
Upper .....	6-6

### Q

Quarter Trim .....	6-1
--------------------	-----

### R

Reaction Injection Molded (RIM) and Reinforced Reaction Injection Molded (RRIM) Parts .....	1-6
Rear Compartment	
Ajar Switch .....	7-4
Cover Extension .....	6-2
Hinge .....	7-1
Lid .....	7-1
Lid Adjustment .....	7-4
Lid Lock Assembly .....	7-3
Lock Cylinder .....	7-3
Liner .....	7-6
Side Panel Cover .....	6-2
Striker .....	7-2
Torque Rods .....	7-2
Weatherstrip .....	7-5
Rear End .....	7-1
Fascia .....	7-8
Rear Quarter	
Fender Finish Molding .....	6-7
Fender Panel Assembly .....	6-7
Quarter Trim Panel .....	6-3
Roof Panel Assembly .....	6-9
Rear Wheelhouse Panel .....	6-7
Rear Window Defogger .....	10-1
Rearview Mirror Support, Bonded .....	11-5
Recliner Control Mechanism .....	9-3
Reclining Seatback .....	9-2
Regulator - Door Window .....	5-15
Remote Control Deck Lid Release	
Solenoid .....	7-4
Remote Control Mirror - Manual .....	5-12
Removal of Minor Scratches and Abrasions - Glass .....	11-1
Replacement Lock Cylinders .....	1-1
Restraint Systems .....	9-1
Reveal Moldings, Windshield and Back	
Glass .....	11-2
Rocker Panel Cover .....	6-1
Roof	
Drip Moldings .....	8-4
Panel .....	8-1
Vista Vent .....	8-4



**S**

Seats

- Adjuster Assembly ..... 9-5
- Adjuster Control Arm Knob ..... 9-4
- Adjuster Diagnosis Chart ..... 9-7
- Adjustments at Floor Plan
  - Attachment ..... 9-4
  - Assembly ..... 9-4
  - Torque Specifications ..... 9-3
- Seatback Assembly ..... 9-3
- Seatback to Motor Compartment Panel ..... 3-1
- Sheet Molded Compound ..... 1-6
- Shoulder Belt Comfort Lock
  - Operational Checks ..... 9-1
- Shroud - Top Vent Screen ..... 4-1
- Speaker Assembly ..... 6-3
- Special Body Tools ..... 1-11
- Spring Clips ..... 5-7
- Stationary Glass ..... 11-2
- Strikers
  - Door ..... 5-9
  - Hood ..... 4-4
  - Rear Compartment ..... 7-2
- Sunshade Assembly ..... 8-4

**T**

- Tail Lamp Assembly ..... 7-6
- Test for Plastic Identification ..... 1-10
- Test for Polypropylene and ABS Plastic ..... 1-10
- Test for Vinyl Plastic ..... 1-10
- Testing Grid Lines - Defogger ..... 10-1
- Tools - Special Body ..... 1-11
- Top Shroud Vent Duct Screen ..... 4-1
- Torque Rods, Rear Compartment ..... 7-2
- Trim
  - Applique Panel ..... 6-5
  - Door Trim Panel ..... 5-2
  - Seatback to Motor Compartment ..... 3-1

**U**

- Underbody Alignment Checking ..... 3-1
- Underbody Dimensions ..... 3-5
- Upper Pressure Relief Valve ..... 6-6

**V**

- Valve, Pressure Relief
  - Lower ..... 6-5
  - Upper ..... 6-6
- Ventilation ..... 4-1
- Vertical Underbody Dimensions ..... 3-5
- Vinyl Reveal Molding - Stationary
  - Glass ..... 11-2
- Vista Vent ..... 8-4

**W**

- Water Deflector
  - Door Inner Panel ..... 5-5
  - Plenum Chamber ..... 4-1
- Waterleak Correction - Stationary Glass ..... 11-5
- Waterleak Diagnosis ..... 1-2
- Waterleak Repair ..... 1-3
- Weatherstrip
  - Door Opening ..... 5-5
  - Rear Compartment ..... 7-5
  - Vista Vent ..... 8-6
- Window Assembly
  - Door Glass Adjustment ..... 5-14
  - Front Glass Run Channel and
    - Support Assembly ..... 5-17
    - Inner Panel Cam Assembly ..... 5-17
    - Rear Cam Guide ..... 5-17
    - Regulator Assembly ..... 5-15
    - Regulator Handle ..... 5-1
  - Window Regulator Cam Assembly ..... 5-14
- Windshield and Back Glass Reveal
  - Molding ..... 11-2
- Windshield Removal and Installation ..... 11-3
- Wiring Harness Illustrations ..... 10-3/13